

RC(L)4710 & RCM(L)4710 Models

Specifications & Capacities	
Horsepower range	55-250 hp (41-186.4 kW)
Gearbox horsepower	540 rpm or 1000 rpm 250hp (186.4 kW) Divider and 210hp (156.6 kW) Center & Wing
Gearbox lubrication	Gear Lube 80-90W EP
Gearbox oil capacity	Splitter: 3.5 pints (1.66 L); Center deck & Wing: 6 pints (2.84 L)
Cutting capacity	4" (10.2 cm)
Machine weight	5,160 lbs (2340.5 kg)
Total weight	1,948 lbs (883.6 kg)
Tongue weight	
Blade tip speed	Center Blades & Wing Blades = 16,300 FPM (82.8 mps)
At 540 rpm	Center Blades = 16,300 FPM (82.8 mps) & Wing Blades = 16,000 FPM (81.3 mps)
At 1000 rpm	
Hitch types	Swivel Clevis Hitch, LP Performance Hitch, Bar-Tite Hitch, Ball Hitch, or Pintle Hitch.
Hitch jack	Standard (7,000 lbs.) (3175.1 kg)
Signal lights	LED
7 Pin connector	SAE J560 pin configuration
Cutting width	10'-0" (4.57 m)
Overall width	11'-7" (4.83 m)
Transport width with 21" tires	10'-3" (3.12 m) - Single-acting fold option, 7'-3" (2.21 m) - Dual-acting fold option.
Overall length	16'-3" (4.95 m) - With center deck raised fully up.
Deck height	12" (30.5 cm)
Cutting height	1-1/2" - 16" (3.8 cm - 40.6 cm) - Varies by tire option.
Lift hydraulics	3" x 8" (7.6 cm x 20.3 cm) hydraulic cylinder, hoses, fittings & stroke control spacers.
Wing flex while operating	Max. 20° down, can float up as needed as long as the wheel(s) are still on the ground.
Wing hydraulics	2 1/2" x 12" (6.4 cm - 30.5 cm) hydraulic cylinder, hoses & fittings.
Wing transport protection	Wing Transport Lock Pin
Deck material thickness	10 Gauge (3.4 mm)
Side skirt thickness	1/4" (6 mm) Steel
Skid shoes	Wing Deck: 1 Replaceable skid shoe. Weight Box: 3 Replaceable skid shoes Center Deck: 2 Replaceable skid shoes and multiple mounting locations.
Blades - 6 (2 per carrier)	1/2" x 4" (1.3 cm - 10.2 cm) Heat-treated, free-swinging alloy steel with uplift.
Blade overlap	6" (15.2 cm)
Blade bolt	Keyed with hardened flat washer & locknut.
Stump jumper / blade holder	3/16" (5 mm) Thick round dish shaped pan, reinforced with 1" x 4" (2.5 x 10.2 cm) blade bar.
Front & rear guards	Optional single row chain or dual row chain.
Input driveline 540 & 1000 rpm	Cat. 6 with constant velocity u-joint with or without overrunning clutch.
Intermediate driveline	Standard - Category 4 with slip-clutch.
Wing drivelines	Standard - Category 4 with slip-clutch or Category 5 with slip-clutch.
Wheel options	21" (53.3 cm) or 26" (66 cm) Laminated tires 24" (61 cm) Used aircraft, foam filled tires 25.5" (64.8 cm) 20 ply tires, foam filled or pneumatic 29" (73.7 cm) Used aircraft tires
Number of wheels	5 - Wheel option: Four on transport axle and one on wing axle. 6 - Wheel option: Four on transport axle and two on wing axle.
Transport axle	Many configurations to choose from.
Hubs	Cast iron five-bolt hubs with tapered roller bearings and 1 3/4" (4.4 cm) shafts.
LP Performance hitch & Bar tite hitch pivot shaft diameter	2 1/4" (5.7 cm)
A-frame tongue	5" x 3" (12.7 cm x 7.6 cm) rectangular tubing

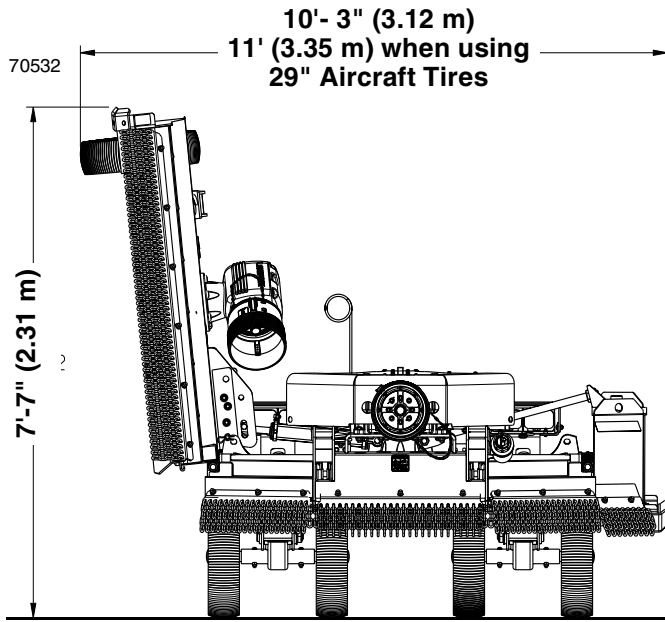

**Transport Width
With Single Action Fold Option**

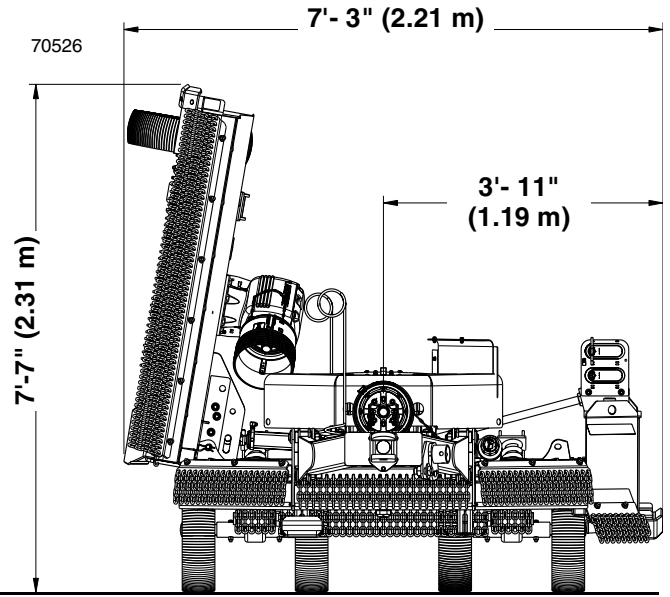

**Narrow Transport Width
With Dual Action Fold Option**

