

RC(M)3712 & RCG(M)3712 Models

Specifications & Capacities		
Horsepower range	hp (kW)	50 - 160 (37.3 - 119.3)
Gearbox horsepower	hp (kW)	540 rpm or 1000 rpm - 160 (119.3) Divider - 130 (96.9) Center & Wings
Gearbox lubrication		Gear Lube 80-90W EP
Gearbox oil capacity		Splitter: 3.5 pints; Center deck & Wings: 6 pints
Cutting capacity	inches (cm)	3 (7.6)
Machine total weight	lbs. (kg)	3,730 (1691.9)
Drawbar vertical load		1,240 (562.5)
Blade tip speed	fpm (mps)	15,500 (78.7)
At 540 rpm		15,700 (79.8)
At 1000 rpm		
Hitch types		Swivel Clevis Hitch, LP Performance Hitch, Bar-Tite Hitch, Ball Hitch, or Pintle Hitch
Hitch jack	lbs. (kg)	Standard 7,000 (3175.1)
Signal lights		LED
7 Pin connector		SAE J560 pin configuration
Cutting width	inches (m)	12'-0" (3.66)
Overall width		12'-10" (3.91)
Transport width		9'-4" (2.84)
Overall length	inches (m)	15'-3" (4.65) With center deck raised fully up
Deck height	inches (cm)	11 (27.9)
Cutting height	inches (cm)	1-1/2 - 14 (3.8 - 35.6)
Lift hydraulics	inches (cm)	3" x 8" (7.6 x 20.3) hydraulic cylinder, hoses, fittings & stroke control spacers
Wing hydraulics	inches (cm)	2 1/2 x 12 (6.4 x 30.5) hydraulic cylinders, hoses & fittings
Wing transport protection		Wing transport lock pins
Deck material thickness	ga no (mm)	10 Gauge (3.4)
Side skirt thickness	inches (mm)	1/4 (6) Steel
Skid shoes		Wing Deck: 1 Replaceable skid shoe per wing Center Deck: 2 Replaceable skid shoes
Blades - 6 (2 per carrier)	inches (mm)	1/2 x 4 (13 x 10.2) Heat-treated, free-swinging alloy steel with uplift
Blade overlap	inches (cm)	6 (15.2)
Blade bolt		Keyed with hardened flat washer & locknut
Stump jumper / blade holder	inches (mm)	3/16 (5) Thick round dish shaped pan, reinforced with 1 x 4 (25 x 102) blade bar
Front & rear guards		Optional single row chain or dual row chain
Input driveline 540 & 1000 rpm		Cat. 6 with constant velocity u-joint with or without overrunning clutch
Intermediate driveline		Standard - Category 4 with slip-clutch
Wing drivelines		Standard - Category 4 with slip-clutch
Wheel options		21" or 26" Laminated tires, 25.5" New foam filled tires, 25.5" New aircraft tires without foam filling 24" Used aircraft tires
Number of wheels		4 - Wheel option: Two on transport axle and one on each wing axle 6 - Wheel option: Four on transport axle and one on each wing axle
Transport axle		Spring-cushioned on center transport axle
Hubs		Cast iron five-bolt hubs with tapered roller bearings and 1 3/4 (4.4) shafts
Land Pride Performance hitch & Bar-Tite hitch pivot shaft diameter	inches (cm)	2 1/4 (5.7)
A-frame tongue	inches (cm)	5 x 3 (12.7 x 7.6) rectangular tubing

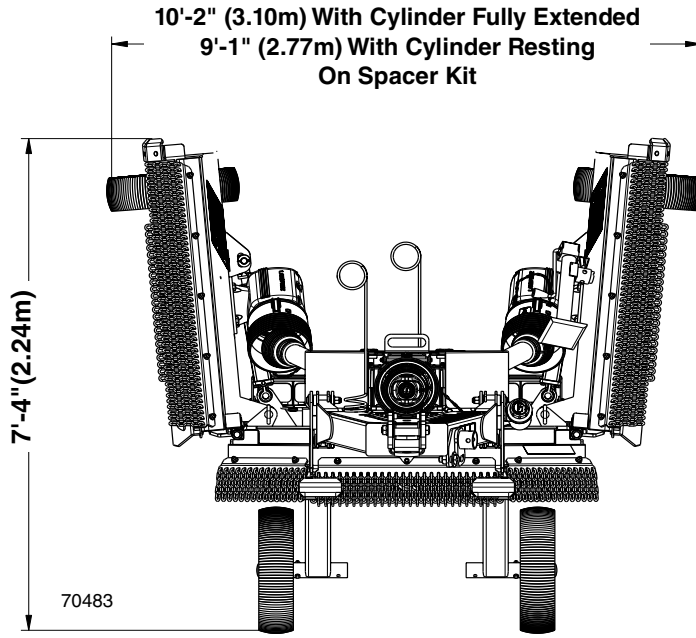

Transport Width
Without Special Adjustments

