

Rotary Cutters

RC(M)4715 & RCG(M)4715

72181

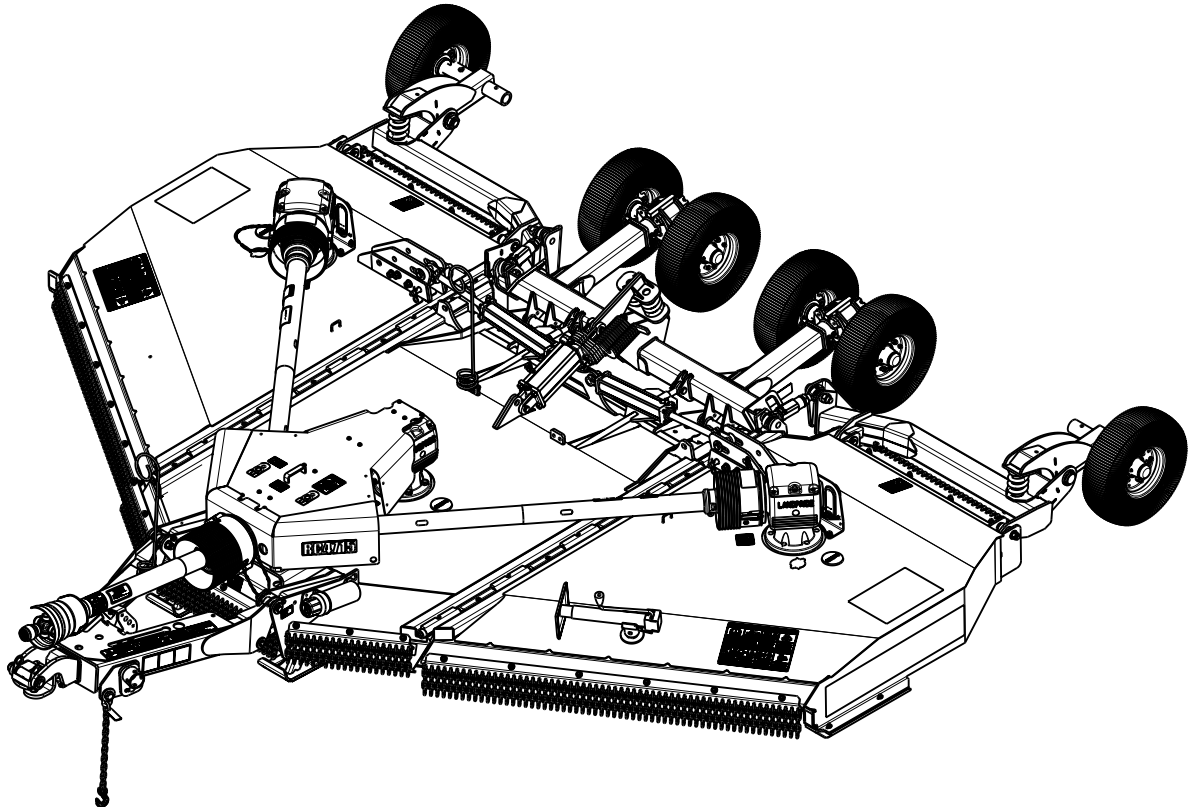

334-113M Operator's Manual



Read the Operator's Manual entirely. When you see this symbol, the subsequent instructions and warnings are serious - follow without exception. Your life and the lives of others depend on it!

Cover photo may show optional equipment not supplied with standard unit.

For an Operator's Manual and Decal Kit in French Language, please see your Land Pride dealer.



Machine Identification

Record your machine details in the log below. If you replace this manual, be sure to transfer this information to the new manual.

If you, or the dealer, have added Options not originally ordered with the machine, or removed Options that were originally ordered, the weights and measurements are no longer accurate for your machine. Update the record by adding the machine weight and measurements provided in the Specifications & Capacities Section of this manual with the Option(s) weight and measurements.

Model Number	
Serial Number	
Machine Height	
Machine Length	
Machine Width	
Machine Weight	
Delivery Date	
First Operation	
Accessories	<hr/> <hr/> <hr/>

Dealer Contact Information

Name: _____

Street: _____

City/State: _____

Telephone: _____

Email: _____

 California Proposition 65 WARNING: Cancer and reproductive harm - www.P65Warnings.ca.gov



Important Safety Information	1	Section 2: Adjustments	29
Safety at All Times	1	Park Jack Angle Alignment	29
Look for the Safety Alert Symbol	1	Lift Cylinder Adjustment	29
Safety Labels	6	Level Cutter Decks	30
Introduction	12	Adjust Cutter Height	31
Application	12	LP Performance Hitch Hole Size	31
Patented	12	Section 3: Operating Instructions	32
Using This Manual	12	Startup Checklist	32
Owner Assistance	12	Safety Information	32
Serial Number	12	Tractor & Cutter Inspection	33
Section 1: Assembly & Set-up	13	Avoid Extreme Turning Angles	34
Tractor Requirements	13	Blade Operation Inspection	34
Drawbar Set-up	13	Transport Pins	34
Hydraulic Outlets	13	Transporting	35
Torque Requirements	13	Field Set-up	36
Before You Start	13	Field Inspections	36
Hitch Types	14	Unfold Wings and Set Deck Cutting Height	36
Swivel Clevis Hitch (Optional)	14	Set Wing Lift Lever to Float Position	36
LP Performance Hitch (Optional)	14	Select Gear Range	36
Bar-Tite Hitch (Optional)	14	Engage Blades	37
Ball Hitch (Optional)	14	Disengage Blades	37
Pintle Hitch (Optional)	14	Blade Carrier Blockage Removal During Field Use	37
Tractor Shutdown Procedure	15	General Operating Instructions	38
Hitch Assembly	15	Section 4: Options & Accessories	39
Attach Park Jack	15	Safety Chain Guards	39
Attach Spring Hose Loop	15	Hitches	39
Swivel Clevis Hitch Hook-up	16	Deck Protection Options	39
LP Performance Hitch Hook-up	17	Wing Fold Options	39
Bar-Tite Hitch Hook-up	18	Tire Options & Configurations	39
Hydraulic Hook-up	19	Axle Options and Configurations	40
Wing Axle Turnbuckle Set-up	20	Single Suspension Center and Wings	40
Unfold Wings	20	Center Axle Options	40
Fold Lock Lugs Set-up	21	HD Single Suspension Center Axle	40
Driveline Assembly	22	Independent Suspension Center Axle	40
Driveline Hook-up to Tractor	23	Walking Tandem Center Axle	40
Driveline Hanger Adjustment	24	Pivot Parallel Center Axle	40
Driveline Clearance Check	24	Wing Axle Options	41
Purge Hydraulic System	25	HD Solid Wing Axles	41
Wing Fold Cylinder	25	Independent Suspension Wing Axles	41
Deck Lift Cylinder	25	Slow Moving Vehicle Sign Accessory	41
Hook-up LED Lights	26	Main Drivelines	42
Remove Shipping Lugs	26	Blade Carrier Options	42
Unhook Rotary Cutter	27	Blade Accessories	42
Relocate SMV Sign	28	Single Duplex Accessory	43
		Dual-Acting Lift Cylinder Accessory	43

Continue Table of Contents on next page



© Copyright 2021 All rights Reserved

Land Pride provides this publication "as is" without warranty of any kind, either expressed or implied. While every precaution has been taken in the preparation of this manual, Land Pride assumes no responsibility for errors or omissions. Neither is any liability assumed for damages resulting from the use of the information contained herein. Land Pride reserves the right to revise and improve its products as it sees fit. This publication describes the state of this product at the time of its publication, and may not reflect the product in the future.

Land Pride is a registered trademark.

All other brands and product names are trademarks or registered trademarks of their respective holders.

Printed in the United States of America.



Table of Contents Continued

Section 5: Maintenance & Lubrication 44
 General Maintenance 44
 Hydraulic System 44
 Tires 44
 Gearbox Driveline Shielding 45
 Wing Gearbox Driveline Shield Access 45
 Center Gearbox Driveline Sliding Shield 45
 Drivelines 46
 Drivelines With Slip Clutches 46
 Clutch Run-in 46
 Clutch Disassembly, Inspection & Assembly 46
 Disassembly 46
 Inspection 47
 Assembly 47
 Cutter Blades 47
 Hitch Wear Points 50
 Skid Shoes 51
 Stroke Control Flip Spacer Replacement 52
 Chain Guards 53
 Long-Term Storage 53
 Ordering Replacement Parts 53
 Lubrication Points 54
 Axle Hub Bearing 54
 Adjustable Turnbuckle 54
 Park Jack 54
 Deck Hinges 55
 Swivel Clevis Hitch (Optional) 55
 LP Performance Hitch (Optional) 55
 Bar-Tite Hitch (Optional) 55
 Gearbox and Divider Box Lubrication 56
 Wing Driveline Shield Grease Point 57
 Wing Driveline Profile Tubes 57
 Wing Driveline Joints 57
 Intermediate Driveline Joints 57
 CV Main Driveline Shield Grease Point 58
 CV Main Driveline Profile Tubes 58
 CV Main Driveline Joints 58
 Accessing CV Driveline Joints 59
Section 6: Specifications & Capacities 60
Section 7: Features & Benefits 62
Section 8: Troubleshooting 64
Section 9: Torque & Tire Inflation Chart 65
Section 10: Warranty 66

Parts Manual QR Locator



The QR (Quick Reference) code on the left will take you to the Parts Manual for this equipment. Download the appropriate App on your smart phone, open the App, point your phone on the QR code and take a picture.

Dealer QR Locator



The QR code on the left will link you to available dealers for Land Pride products. Refer to Parts Manual QR Locator on this page for detailed instructions.

Listed below are common practices that may or may not be applicable to the products described in this manual.

Safety at All Times

Careful operation is your best assurance against an accident.

All operators, no matter how much experience they may have, should carefully read this manual and other related manuals, or have the manuals read to them, before operating the power machine and this implement.

- ▲ Thoroughly read and understand the "Safety Label" section. Read all instructions noted on them.
- ▲ Do not operate the equipment while under the influence of drugs or alcohol as they impair the ability to safely and properly operate the equipment.
- ▲ The operator should be familiar with all functions of the tractor and attached implement, and be able to handle emergencies quickly.
- ▲ Make sure all guards and shields appropriate for the operation are in place and secured before operating the implement.
- ▲ Keep all bystanders away from equipment and work area.
- ▲ Start tractor from the driver's seat with hydraulic controls in neutral.
- ▲ Operate tractor and controls from the driver's seat only.
- ▲ Never dismount from a moving tractor or leave tractor unattended with engine running.
- ▲ Do not allow anyone to stand between tractor and implement while backing up to implement.
- ▲ Keep hands, feet, and clothing away from power-driven parts.
- ▲ While transporting and operating equipment, watch out for objects overhead and along side such as fences, trees, buildings, wires, etc.
- ▲ Do not turn tractor so tight as to cause hitched implement to ride up on the tractor's rear wheel.
- ▲ Store implement in a safe and secure area where children normally do not play. When needed, secure implement against falling with support blocks.



Look for the Safety Alert Symbol

The SAFETY ALERT SYMBOL indicates there is a potential hazard to personal safety and extra precaution must be taken. When you see this symbol, be alert and carefully read the message that follows it. Hazard control, and accident prevention are dependent upon the awareness, concern, prudence, and proper training of personnel involved in the operation, transport, maintenance, and storage of equipment.

Be Aware of Signal Words

A signal word designates a degree or level of hazard seriousness. They are:

- ▲ **DANGER:** Indicates a hazardous situation that, if not avoided, will result in death or serious injury.
- ▲ **WARNING:** Indicates a hazardous situation that, if not avoided, could result in death or serious injury.
- ▲ **CAUTION:** Indicates a hazardous situation that, if not avoided, may result in minor or moderate injury.

Be Aware of Special Notices

Special notices are intended to point out important and helpful information that should be followed. They are usually placed inside a box. They are:

- ▲ **IMPORTANT:** Indicates that equipment or property damage could result if instructions are not followed.
- ▲ **NOTE:** Indicates supplementary explanations that will be helpful when using the equipment.

Safety Precautions for Children

Tragedy can occur if the operator is not alert to the presence of children, Children generally are attracted to implements and their work.

- ▲ Never assume children will remain where you last saw them.
- ▲ Keep children out of the work area and under the watchful eye of a responsible adult.
- ▲ Be alert and shut the implement and tractor down if children enter the work area.
- ▲ Never carry children on the tractor or implement. There is not a safe place for them to ride. They may fall off and be run over or interfere with the control of the power machine.
- ▲ Never allow children to operate the power machine, even under adult supervision.
- ▲ Never allow children to play on the power machine or implement.
- ▲ Use extra caution when backing up. Before the tractor starts to move, look down and behind to make sure the area is clear.

Tractor Shutdown & Storage

- ▲ If engaged, disengage power take-off.
- ▲ Park on solid, level ground and lower implement to ground or onto support blocks.
- ▲ Put tractor in park or set park brake.
- ▲ Turn off engine and remove ignition key to prevent unauthorized starting.
- ▲ Relieve all hydraulic pressure to auxiliary hydraulic lines.
- ▲ Wait for all components to stop before leaving operator's seat.
- ▲ Use steps, grab-handles and anti-slip surfaces when stepping on and off the tractor.

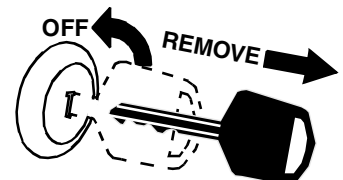

Listed below are common practices that may or may not be applicable to the products described in this manual.

Use A Safety Chain

- ▲ A safety chain will help control drawn machinery should it separate from the tractor drawbar.
- ▲ Use a chain with the strength rating equal to or greater than the gross weight of the towed implement.
- ▲ Attach the chain to the tractor drawbar support or other specified anchor location. Allow only enough slack in the chain to permit turning.
- ▲ Always hitch the implement to the machine towing it. Do not use the safety chain to tow the implement.

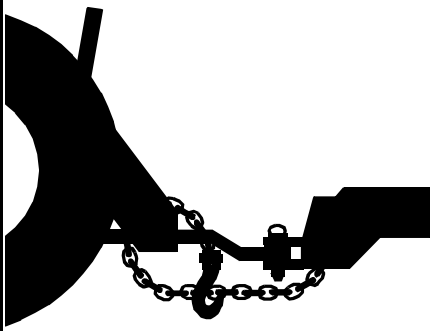

Transport Safely

- ▲ Comply with federal, state, and local laws.
- ▲ Use towing vehicle and trailer of adequate size and capacity. Secure equipment towed on a trailer with tie downs and chains.
- ▲ Sudden braking can cause a towed trailer to swerve unexpectedly. Reduce speed if towed trailer is not equipped with brakes.
- ▲ Avoid contact with any overhead utility lines or electrically charged conductors.
- ▲ Always drive with load on end of loader arms low to the ground.
- ▲ Always drive straight up and down steep inclines with heavy end of skid steer on the "uphill" side.
- ▲ Engage park brake when stopped on an incline.
- ▲ Maximum transport speed for an attached equipment is 20 mph (32 km/h). **DO NOT EXCEED.** Never travel at a speed which does not allow adequate control of steering and stopping. Some rough terrains require a slower speed.
- ▲ As a guideline, use the following maximum speed weight ratios for attached equipment:
 - 20 mph (32 km/h)** when weight of attached equipment is less than or equal to the weight of machine towing the equipment.
 - 10 mph (16 km/h)** when weight of attached equipment exceeds weight of machine towing equipment but not more than double the weight.
- ▲ **IMPORTANT:** Do not tow a load that is more than double the weight of the vehicle towing the load.

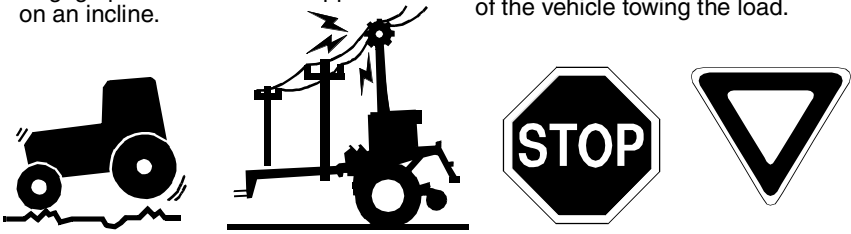

Tire Safety

- ▲ Tire changing can be dangerous and must be performed by trained personnel using the correct tools and equipment.
- ▲ Always properly match the wheel size to the properly sized tire.
- ▲ Always maintain correct tire pressure. Do not inflate tires above recommended pressures shown in the Operator's Manual.
- ▲ When inflating tires, use a clip-on chuck and extension hose long enough to allow you to stand to one side and NOT in front of or over the tire assembly. Use a safety cage if available.
- ▲ Securely support the implement when changing a wheel.
- ▲ When removing and installing wheels, use wheel handling equipment adequate for the weight involved.
- ▲ Make sure wheel bolts have been tightened to the specified torque.



Practice Safe Maintenance

- ▲ Understand procedure before doing work. Refer to the Operator's Manual for additional information.
- ▲ Work on a level surface in a clean dry area that is well-lit.
- ▲ Lower implement to the ground and follow all shutdown procedures before leaving the operator's seat to perform maintenance.
- ▲ Do not work under any hydraulically supported equipment. It can settle, suddenly leak down, or be lowered accidentally. If it is necessary to work under the equipment, securely support it with stands or suitable blocking beforehand.
- ▲ Use properly grounded electrical outlets and tools.
- ▲ Use correct tools and equipment for the job that are in good condition.
- ▲ Allow equipment to cool before working on it.
- ▲ Disconnect battery ground cable (-) before servicing or adjusting electrical systems or before welding on implement.
- ▲ Inspect all parts. Make certain parts are in good condition & installed properly.
- ▲ Replace parts on this implement with genuine Land Pride parts only. Do not alter this implement in a way which will adversely affect its performance.
- ▲ Do not grease or oil implement while it is in operation.
- ▲ Remove buildup of grease, oil, or debris.
- ▲ Always make sure any material and waste products from the repair and maintenance of the implement are properly collected and disposed.
- ▲ Remove all tools and unused parts from equipment before operation.
- ▲ Do not weld or torch on galvanized metal as it will release toxic fumes.



Listed below are common practices that may or may not be applicable to the products described in this manual.

Prepare for Emergencies

- ▲ Be prepared if a fire starts.
- ▲ Keep a first aid kit and fire extinguisher handy.
- ▲ Keep emergency numbers for doctor, ambulance, hospital, and fire department near the phone.

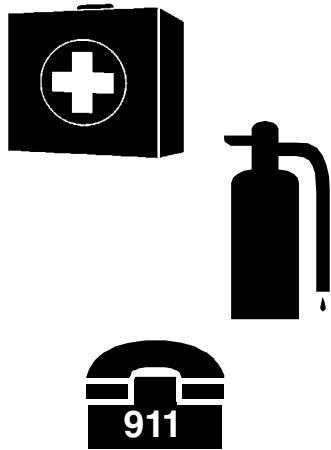

Wear Personal Protective Equipment (PPE)

- ▲ Wear protective clothing and equipment appropriate for the job such as safety shoes, safety glasses, hard hat, dust mask, and ear plugs.
- ▲ Clothing should fit snug without fringes and pull strings to avoid entanglement with moving parts.
- ▲ Prolonged exposure to loud noise can cause hearing impairment or hearing loss. Wear suitable hearing protection such as earmuffs or earplugs.
- ▲ Operating a machine safely requires the operator's full attention. Avoid wearing headphones while operating equipment.



Avoid High Pressure Fluids

- ▲ Escaping fluid under pressure will penetrate the skin or eyes causing serious injury.
- ▲ Relieve all residual pressure before disconnecting hydraulic lines or performing work on the hydraulic system.
- ▲ Make sure all hydraulic fluid connections are properly tightened/torqued and all hydraulic hoses and lines are in good condition before applying pressure to the system.
- ▲ Use a piece of paper or cardboard, NOT BODY PARTS, to check for suspected leaks.
- ▲ Wear protective gloves and safety glasses or goggles when working with hydraulic systems.
- ▲ **DO NOT DELAY.** If an accident occurs, seek immediate emergency medical care or gangrene may result.



Use Safety Lights and Devices

- ▲ A Slow moving power machine can create a hazard when driven on public roads. They are difficult to see, especially at night. Use the Slow Moving Vehicle (SMV) sign when on public roads.
- ▲ Flashing warning lights and turn signals are recommended whenever driving on public roads.

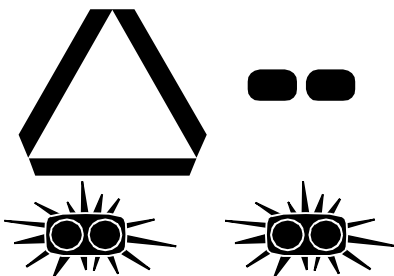

Use Seat Belt and ROPS

- ▲ Land Pride recommends the use of a CAB or roll-over-protective-structures (ROPS) and seat belt in almost all power machines. Combination of a CAB or ROPS and seat belt will reduce the risk of serious injury or death if the power machine should be upset.
- ▲ If ROPS is in the locked-up position, fasten seat belt snugly and securely to help protect against serious injury or death from falling and machine overturn.

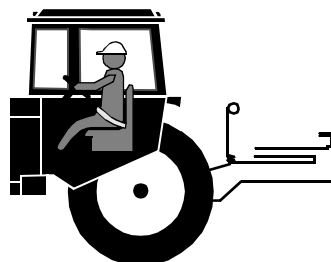

Keep Riders Off Machinery

- ▲ Never carry riders on the tractor or implement.
- ▲ Riders obstruct operator's view and interfere with the control of the power machine.
- ▲ Riders can be struck by objects or thrown from the equipment.
- ▲ Never use the tractor or implement to lift or transport riders.

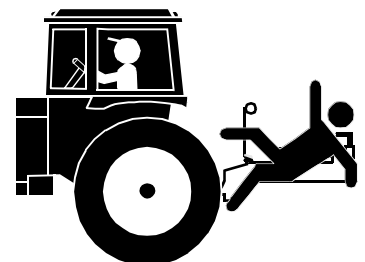

Listed below are common practices that may or may not be applicable to the products described in this manual.

Avoid crystalline Silica (quartz) Dust

Because crystalline silica is a basic component of sand and granite, many activities at construction sites produce dust containing crystalline silica. Trenching, sawing, and boring of material containing crystalline silica can produce dust containing crystalline silica particles. This dust can cause serious injury to the lungs (silicosis).

There are guidelines which should be followed if crystalline silica (quartz) is present in the dust.



- ▲ Be aware of and follow OSHA (or other local, State, or Federal) guidelines for exposure to airborne crystalline silica.
- ▲ Know the work operations where exposure to crystalline silica may occur.
- ▲ Participate in air monitoring or training programs offered by the employer.
- ▲ Be aware of and use optional equipment controls such as water sprays, local exhaust ventilation, and enclosed cabs with positive pressure air conditioning if the machine has such equipment. Otherwise respirators shall be worn.
- ▲ Where respirators are required, wear a respirator approved for protection against crystalline silica containing dust. Do not alter respirator in any way. Workers who use tight-fitting respirators can not have beards/mustaches which interfere with the respirator seal to the face.
- ▲ If possible, change into disposable or washable work clothes at the work site; shower and change into clean clothing before leaving the work site.
- ▲ Do not eat, drink, use tobacco products, or apply cosmetics in areas where there is dust containing crystalline silica.
- ▲ Store food, drink, and personal belongings away from the work area.
- ▲ Wash hands and face before eating, drinking, smoking, or applying cosmetics after leaving the exposure area.

Handle Chemicals Properly

- ▲ Protective clothing should be worn.
- ▲ Handle all chemicals with care.
- ▲ Follow instructions on container label.
- ▲ Agricultural chemicals can be dangerous. Improper use can seriously injure persons, animals, plants, soil, and property.
- ▲ Inhaling smoke from any type of chemical fire can be a serious health hazard.
- ▲ Store or dispose of unused chemicals as specified by the chemical manufacturer.



Dig Safe - Avoid Underground Utilities

- ▲ **USA: Call 811**
CAN: digsafecanada.ca
Always contact your local utility companies (electrical, telephone, gas, water, sewer, and others) before digging so that they may mark the location of any underground services in the area.
- ▲ Be sure to ask how close you can work to the marks they positioned.





This page left blank intentionally.

Important Safety Information

Safety Labels

Your Folding Rotary Cutter comes equipped with all safety labels in place. They were designed to help you safely operate your equipment. Read and follow their directions.

1. Keep all safety labels clean and legible.
2. Refer to this section for proper label placement. Replace all damaged or missing labels. Order new labels from your nearest Land Pride dealer. To find your nearest dealer, visit our dealer locator at www.landpride.com.
3. Some new equipment installed during repair requires safety labels to be affixed to the replaced component as

specified by Land Pride. When ordering new components make sure the correct safety labels are included in the request.

4. Refer to this section for proper label placement. To install new labels:
 - a. Clean surface area where label is to be placed.
 - b. Spray soapy water onto the cleaned area.
 - c. Peel backing from label and press label firmly onto the surface.
 - d. Squeeze out air bubbles with edge of a credit card or with a similar type of straight edge.

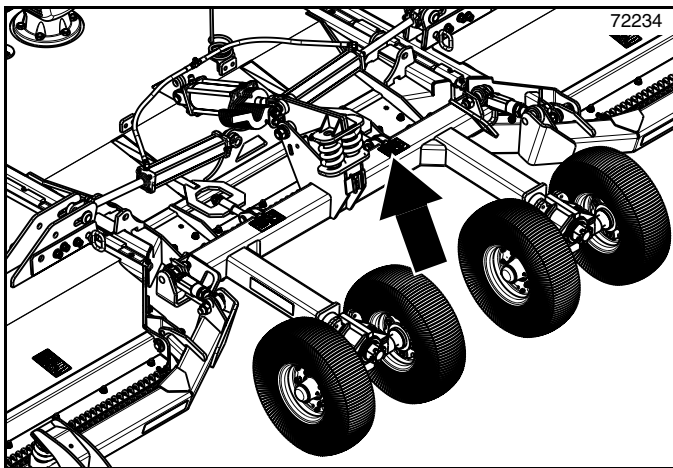
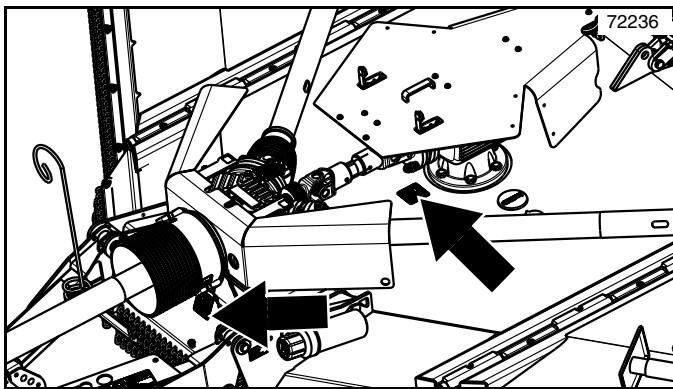
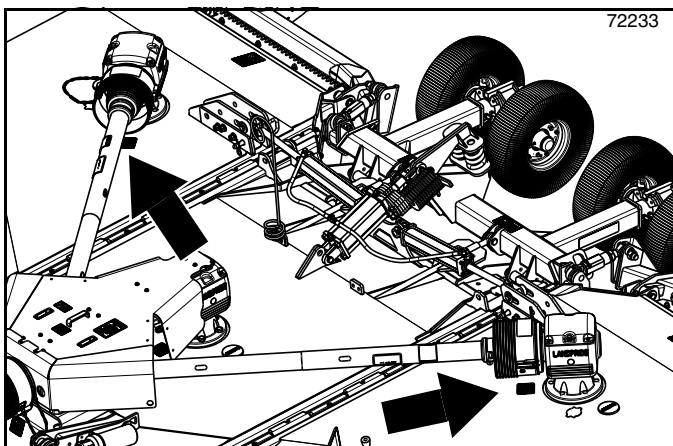

858-956C

DANGER: Entanglement Hazard
(4 Places) Located under all drivelines.



858-951C

WARNING: Crushing Hazard
(1 Place) Located on Center Axle.

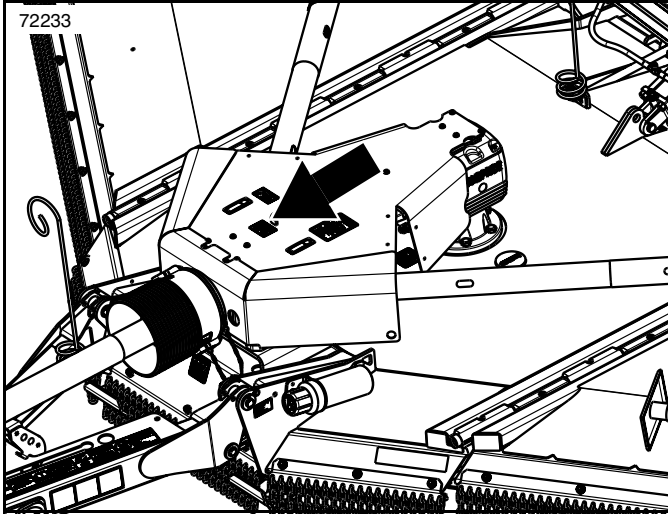

818-130C

WARNING: Use 540 rpm power take-off RC Series cutters only.
(1 Place) Located on top of sliding shield.



818-240C

WARNING: Use 1000 rpm power take-off RCM Series cutters only.
(1 Place) Located on top of sliding shield.

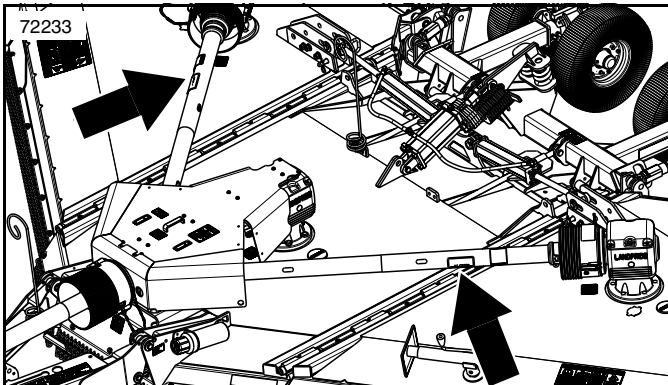

818-552C

DANGER: Rotating Driveline - Keep Away
(4 Places) Located on top of sliding shield, main driveline, and both wing drivelines.

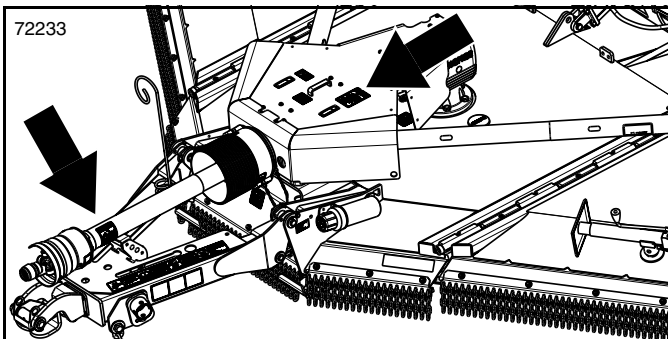

818-142C

DANGER: Rotating Driveline - Keep Away
(2 Places) Located on left and right drivelines.

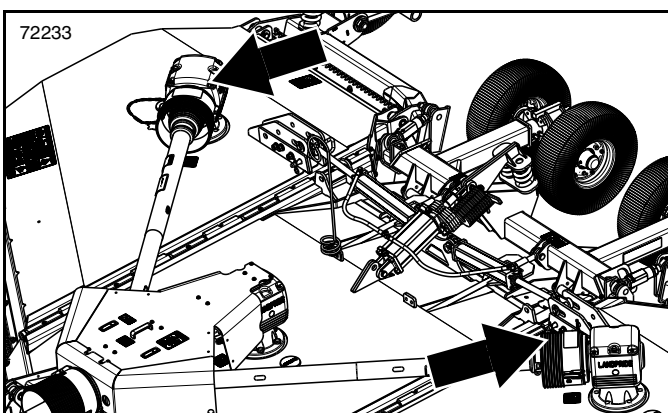

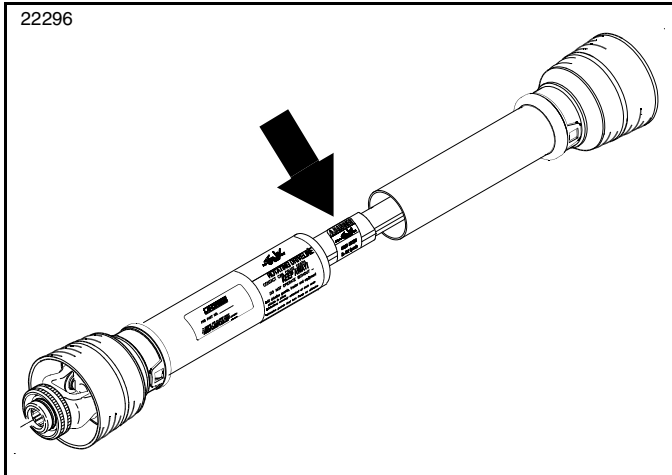

818-540C

DANGER: Guard Missing - Do Not Operate (3 Places) Located on main and two wing drivelines.

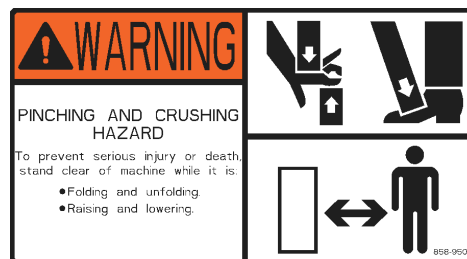
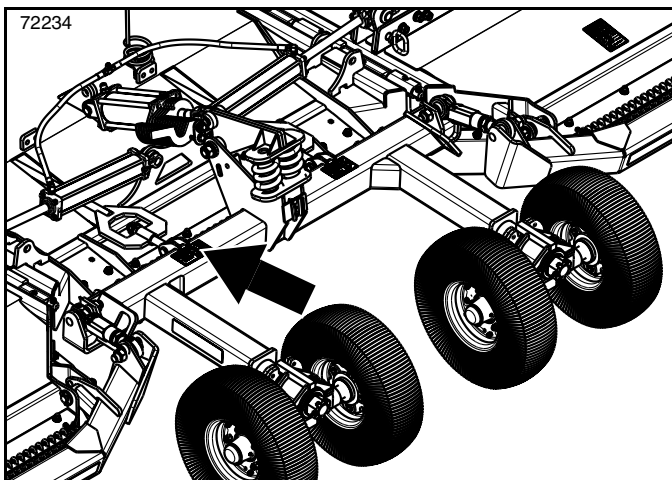

858-950C

WARNING: Pinching and Crushing Hazard (1 Place) Located on center axle.

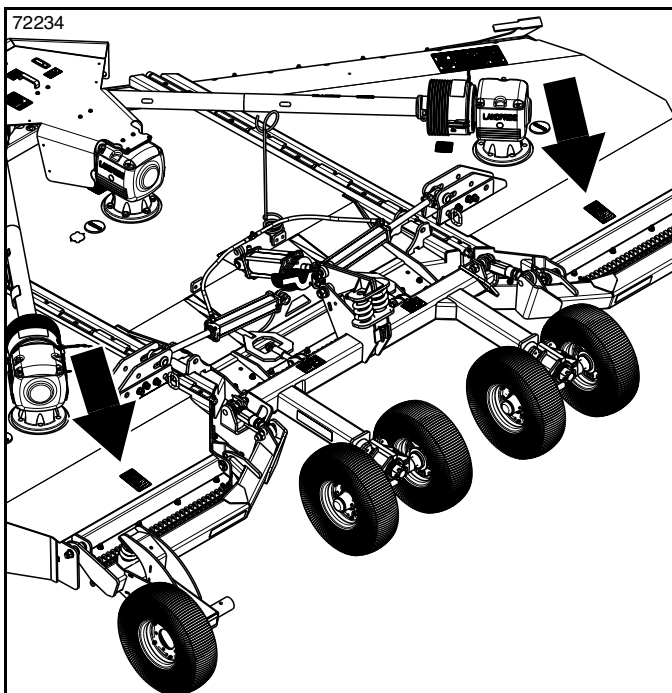

858-947C

DANGER: Thrown Object and Rotating Blade Hazard (2 Places) Located on back side of left and right wing.



<p>! WARNING</p>	<p>! DANGER</p>	<p>! DANGER</p>	<p>! DANGER</p>
			
<p>To prevent serious injury or death:</p> <ul style="list-style-type: none"> Do not operate or work on this machine without reading and understanding the Operator's Manual. Avoid unsafe operation or maintenance. Transport with clean reflectors, SMV, and lights as required by federal, state, and local laws. If manual is lost, contact your nearest dealer for a new manual. 	<p>ROTATING DRIVELINE CONTACT CAN CAUSE DEATH KEEP AWAY!</p> <p>DO NOT OPERATE WITHOUT:</p> <ul style="list-style-type: none"> All driveline guards, tractor and equipment shields in place. Drivelines securely attached at both ends. Driveline guards that turn freely on driveline. <p>DO NOT USE PTO ADAPTORS</p>	<p>THROWN OBJECT AND ROTATING BLADE HAZARD</p> <p>To prevent serious injury or death:</p> <ul style="list-style-type: none"> Do not operate unless all guards are installed and in good condition. Inspect and clear debris from mowing area prior to mowing. Do not operate with bystanders in or around mowing area. Do not place hands or feet under deck when operating or when engine is running. Do not operate with wing(s) raised. Do not operate without wing(s) or weight box. 	<p>CRUSHING HAZARD</p> <p>To prevent serious injury or death:</p> <ul style="list-style-type: none"> Do not transport without transport locks securely engaged. Do not walk or work underneath raised wing unless it is securely locked. Stay clear of wings while they are being raised and lowered.
<p>! WARNING</p>	<p>! WARNING</p>	<p>! WARNING</p>	<p>! WARNING</p>
			
<p>CRUSHING HAZARD</p> <p>Before performing maintenance on machine and to prevent serious injury or death:</p> <ul style="list-style-type: none"> Read an understand operator's manual. Stop engine, set brake, and wait for all moving parts to stop before dismounting. Support mower securely and apply any supplied hydraulic cylinder locks before working beneath. 	<p>RUN OVER HAZARD</p> <p>To prevent serious injury or death:</p> <ul style="list-style-type: none"> Always use seat belt when operating. Never allow riders on tractor or machine. 	<p>ROLLOVER HAZARD</p> <p>To prevent serious injury or death:</p> <ul style="list-style-type: none"> Always use seat belt when operating. Only operate on tractors equipped with a rollover protective structure (ROPS). If equipped with foldable ROPS, only operate in the unfolded and locked position. Use caution when mowing along inclines. 	<p>ROLLOVER HAZARD</p> <p>To prevent serious injury or death:</p> <ul style="list-style-type: none"> Do not transport on an incline with wing(s) raised. Do not transport without wing or weight box.

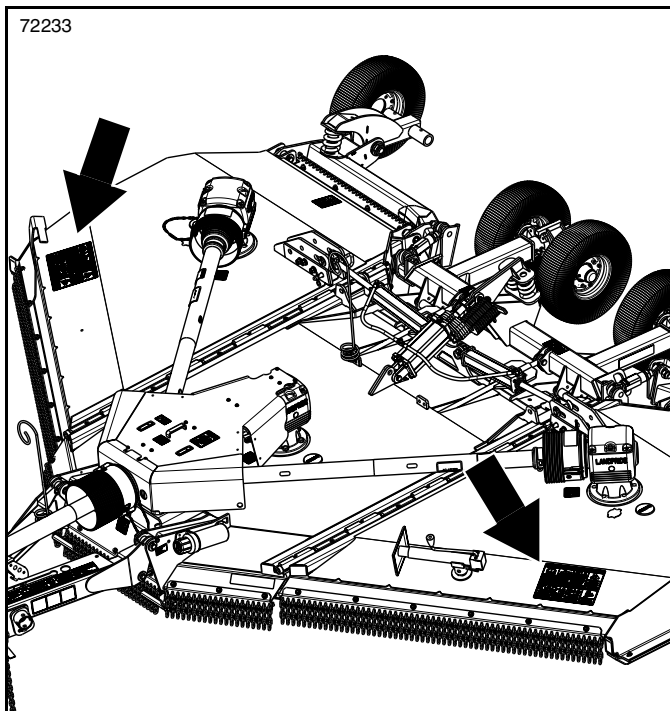

858-949C

Cutter Safety Combo
(2 Places) Located on the left and right wing decks.

Important Safety Information

	<p>! DANGER</p> <p>CRUSHING HAZARD To prevent serious injury or death:</p> <ul style="list-style-type: none"> • Do not stand between implement and tractor when hitching together. • Keep others away. 		<p>! WARNING</p> <p>To prevent serious injury or death:</p> <ul style="list-style-type: none"> • Avoid unsafe operation or maintenance. • Do not operate or work on this machine without reading and understanding the Operator's Manual. • If manual is lost, contact your nearest dealer for new manual.
--	--	--	--

	<p>! WARNING</p> <p>HIGH PRESSURE FLUID HAZARD To prevent serious injury or death:</p> <ul style="list-style-type: none"> • Relieve pressure on system before repairing, adjusting, or disconnecting. • Wear proper hand and eye protection when searching for leaks. Use wood or cardboard instead of hands. • Keep all components in good repair. 		<p>! WARNING</p> <p>Do not exceed 20 miles per hour transport speed. To prevent machine damage, limit speed while:</p> <ul style="list-style-type: none"> • Transporting. • Turning. • In windy conditions. • In rough and hilly terrain. <p style="text-align: right;">858-954C</p>
--	--	--	---

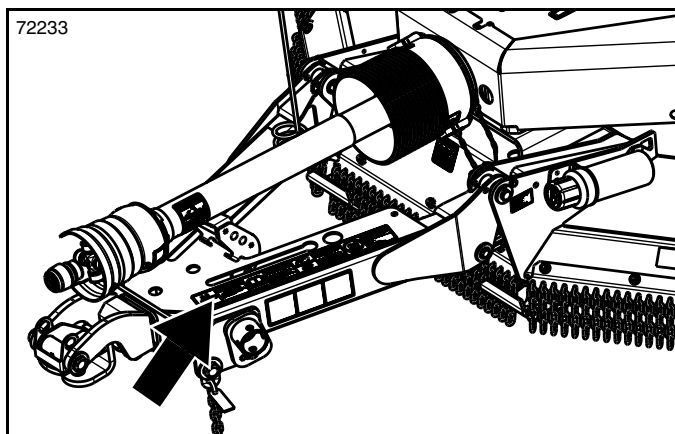

858-954C

Hitch Safety Combo
(1 Place) Located on Hitch Assembly.

Important Safety Information

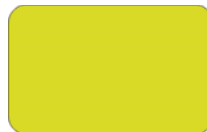
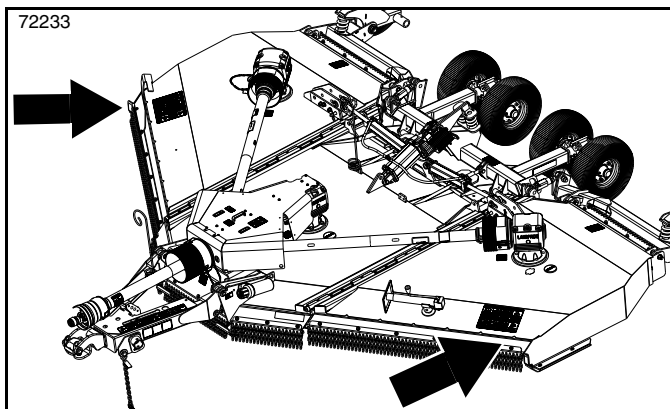

818-229C

1 3/4" x 2 3/4" Amber Reflector
(2 Places) Located on front side of left and right wing decks.

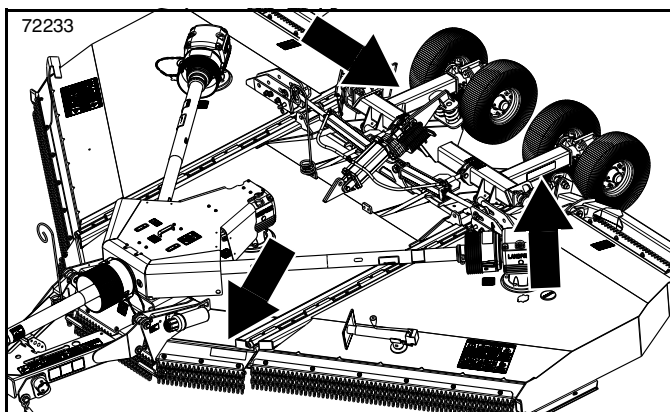

838-615C

2" x 9" Amber Reflector
(3 Places) Located on front left side of center deck and on right and left side of center axle.

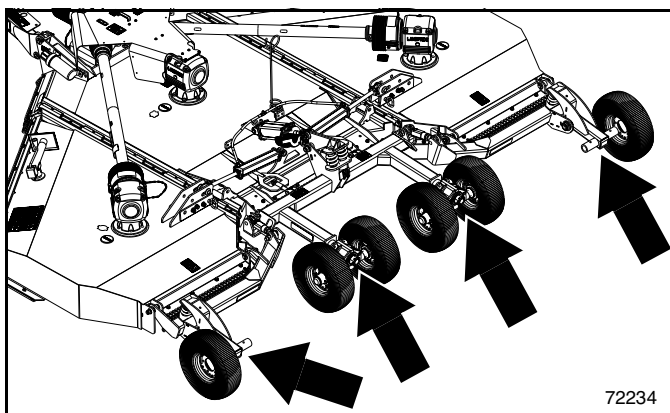

818-230C

1 11/16" x 2 13/16" Red Reflector
(4 Places) Located on back side of axle spindles.

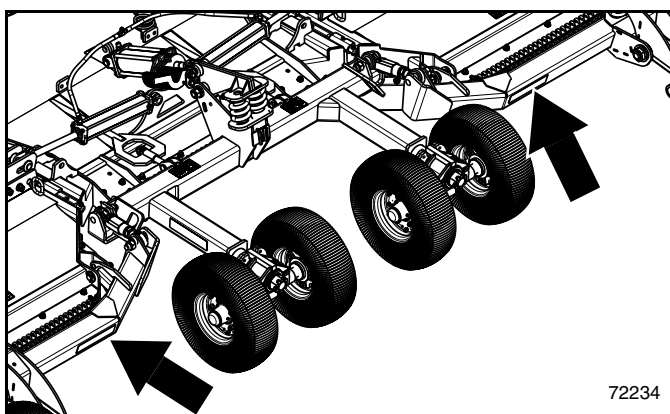

838-614C

2" x 9" Red Reflector
(2 Places) Located on back side of left and right wing axles.



Introduction

Land Pride welcomes you to the growing family of new product owners. This Rotary Cutter has been designed with care and built by skilled workers using quality materials. Proper assembly, maintenance, and safe operating practices will help you get years of satisfactory use from this Rotary Cutter.

Application

The RC4715, RCM4715, RCG4715 and RCGM4715 Rotary Cutters are designed and built by Land Pride with many design options to provide superior cutting performance on gently sloping or slightly contoured right-of-ways, pastures, orchards, set-aside acres or row crop fields. The 15' (4.6 m) cutting width and ability to cut weeds and brush up to 4" (10 cm) in diameter makes this Rotary Cutter series well equipped for all listed applications.

All listed models offer a pull-type, narrow A-frame hitch, and a Cat.6 constant velocity main driveline for attachment to 55-250 hp (41-186.4 kW) tractors. The RC4715 and RCG4715 attach to 540 rpm tractors, while the RCM4715 and RCGM4715 attach to 1000 rpm tractors.

To accommodate specific applications, Land Pride offers a multitude of options such as hitch types, driveline packages, tires, safety guards, axle combinations, and blade carriers. See **"Section 4: Options & Accessories"** starting on page 39 for additional information.

See **"Specifications & Capacities"** on page 60 and **"Features & Benefits"** on page 62 for additional information on the unique specifications and features of these Rotary Cutters.

Patented

This cutter is protected by one or more of the following patent numbers:

- US 10,064,330
- US 10,130,025
- US 10,844,883

Using This Manual

- This Operator's Manual is designed to help familiarize the operator with safety, assembly, operation, adjustments, troubleshooting, and maintenance. Read this manual and follow the recommendations to help ensure safe and efficient operation.
- The information contained within this manual was current at the time of printing. Some parts may change slightly to assure you of the best performance.
- To order a new Operator's or Parts Manual, contact your authorized dealer. Manuals can also be downloaded, free-of-charge, from our website at www.landpride.com.

Terminology

"Right" or "Left" as used in this manual is determined by facing forward in the direction the machine will operate while in use unless otherwise stated.

Owner Assistance

The dealer should complete the Online Warranty Registration at the time of purchase. This information is necessary to provide you with quality customer service.

The parts on your Rotary Cutter have been specially designed by Land Pride and should only be replaced with genuine Land Pride parts. Contact a Land Pride dealer if customer service or repair parts are required. Your Land Pride dealer has trained personnel, repair parts, and equipment needed to service the implement.

Serial Number

For quick reference and prompt service, record model and serial number on the inside cover page and again on the warranty page of this manual. Always provide model number and serial number when ordering parts and in all correspondences with your Land Pride dealer. For location of your serial number plate, see Figure 1 below.

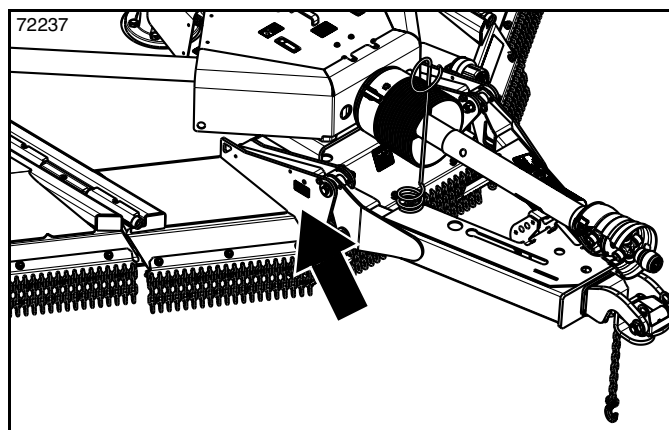

Serial Number Plate Location
Figure 1

Further Assistance

Your dealer wants you to be satisfied with your new Rotary Cutter. If for any reason you do not understand any part of this manual or are not satisfied with the service received, the following actions are suggested:

1. Discuss any problems you have with your implement with your dealership service personnel so they can address the problem.
2. If you are still not satisfied, seek out the owner or general manager of the dealership, explain the question/problem, and request assistance.
3. For further assistance write to:

Land Pride Service Department
1525 East North Street

P.O. Box 5060
Salina, Ks. 67402-5060

E-mail address
lp servicedept@landpride.com



Section 1: Assembly & Set-up

Tractor Requirements

Tractor horsepower should be within the range noted below. Tractors outside the horsepower range must not be used.

- Horsepower Rating 55-250 hp (41-186.4 kW)
- Hitch Type (See Drawbar Set-up) Drawbar
- Rear Power Take-off Speed:
 - RC4715 540 rpm
 - RCG4715 540 rpm
 - RCM4715 1000 rpm
 - RCGM4715 1000 rpm
- Hydraulic Outlets (See Hydraulic Set-up)
 - Factory Standard 2 duplex outlets
- Electrical 7-pin outlet

Drawbar Set-up

Figure 1-1:

WARNING

To prevent serious injury or death:

- Do not use a tractor that is too small or too large. Small tractors can be pushed around and flipped over. Large tractors can damage the attached implement.
- Do not use a power take-off adapter. The adapter will increase strain on the tractor’s power take-off shaft causing possible damage to shaft and driveline. It will also defeat the purpose of the tractor’s power take-off shield.
- Power take-off damage may occur if distances “A” and “B” are not properly maintained.

Maintain proper distance, dimension “A,” between center of drawbar hitch pin hole and end of tractor power take-off shaft.

540 rpm & 1 3/8", 1000 rpm power take-off speed:

- “A” 14"- 16" (35.6 cm - 41.6 cm)
- “B” 8"- 10" (20.3 cm - 25.4 cm)
- “C” 18"- 22" (45.7 cm - 55.9 cm)

1 3/4", 1000 rpm power take-off speed:

- “A” 18"- 20" (45.7 cm - 50.8 cm)
- “B” 10"- 12" (25.4 cm - 30.5 cm)
- “C” 18"- 22" (45.7 cm - 55.9 cm)

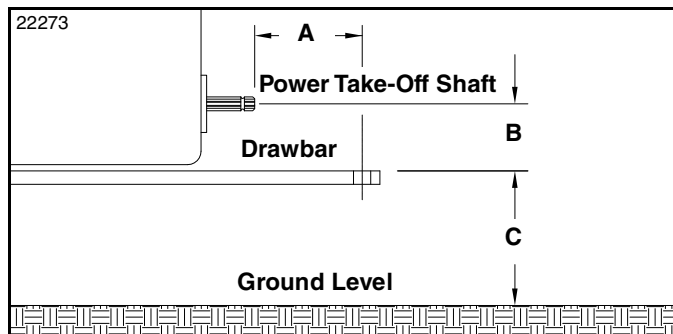

Power Take-off Drawbar Distance
Figure 1-1

Hydraulic Outlets

Depending on purchased fold option, two to three duplex outlets are required. Two outlets are needed when choosing a fold option where the wings fold simultaneously. Three outlets are needed when choosing a fold option where the wings fold independently.

Land Pride highly recommends connecting the wing fold hose(s) to a duplex outlet with float capabilities and use the float when in field operation.

Accessory available to convert from two duplexes to one duplex. See “Single Duplex Accessory” on page 43.

Torque Requirements

See “Torque Values Chart for Common Bolt Sizes” on page 65 to determine correct torque values when tightening hardware. View bottom of chart for “Additional Torque Values” for exceptions to common torque values.

Before You Start

Be sure to read and fully understand this Operator’s Manual. An understanding of how the Rotary Cutter works will aid in the assembly and setup of your machine.

It is best to go through the “Pre-Assembly Checklist” on this page before assembling the Rotary Cutter. To speed up your assembly task and make the job safer, have all needed parts and equipment readily at hand.

Pre-Assembly Checklist

✓	Check	Ref.
<input type="checkbox"/>	Have a hoist, fork lift, or loader with properly sized chains and safety stands capable of lifting and supporting the equipment on hand.	
<input type="checkbox"/>	Have a minimum of two people available during assembly.	
<input type="checkbox"/>	Make sure all major components and loose parts are shipped with the machine.	Operator’s Manual
<input type="checkbox"/>	Double check to make sure all parts, fasteners, and pins are installed in the correct location. Refer to the Parts Manual if unsure. By double checking, you will lessen the chance of using a bolt incorrectly that may be needed later. NOTE: All assembled hardware from the factory has been installed in the correct location. Remember location of a part or fastener if removed. Keep parts separated.	Operator’s Manual 334-113M Parts Manual 334-113P
<input type="checkbox"/>	Make sure working parts move freely, bolts are tight & cotter pins are spread.	Operator’s Manual
<input type="checkbox"/>	Make sure all safety labels are correctly located and legible. Replace if damaged.	Page 6
<input type="checkbox"/>	Make sure lights are functioning properly.	Page 26
<input type="checkbox"/>	Make sure safety guards are installed and in good working order.	45 & 53
<input type="checkbox"/>	Make sure all grease fittings are in place and lubricated.	Page 54
<input type="checkbox"/>	Make sure all pneumatic tires are properly inflated and all wheel bolts and axle nuts are tightened to the specific torque.	Page 65

Section 1: Assembly & Set-up

Hitch Types

Shown below are five different hitch options available for your Rotary Cutter. Visit your nearest Land Pride dealer to inquire about or purchase a new hitch option.

Swivel Clevis Hitch (Optional)

Refer to Figure 1-2:

The Swivel Clevis Hitch pivots side-to-side up to 35 degrees each direction. It features a stop to prevent the hitch from being installed upside down. Customer to supply hitch pin and hitch pin keeper.

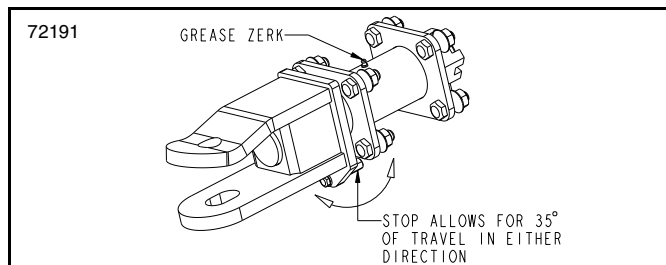

Swivel Clevis Hitch
Figure 1-2

LP Performance Hitch (Optional)

Refer to Figure 1-3:

The LP Performance Hitch is a drawbar friendly, self-leveling hitch that pivots up and down, and side-to-side. It is held upright with a customer supplied hitch pin to allow single-person hook up.

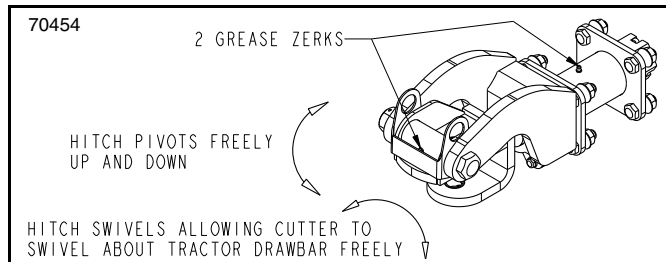

LP Performance Hitch
Figure 1-3

Bar-Tite Hitch (Optional)

Refer to Figure 1-4:

The Bar-Tite Hitch functions similar to the LP Performance hitch except it clamps directly to the drawbar. The Bar-Tite Hitch is sandwiched between hardened steel plates to eliminate drawbar wear.

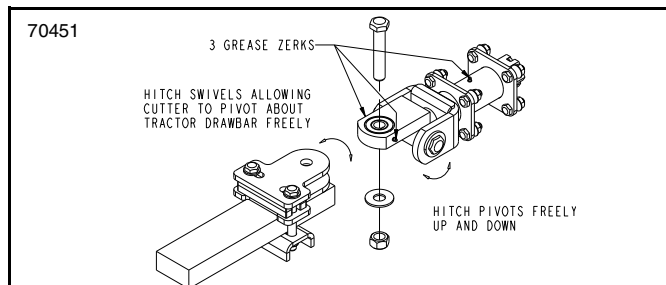

Bar-Tite Hitch
Figure 1-4

Ball Hitch (Optional)

Refer to Figure 1-5:

The Ball Hitch allows the cutter to swivel about a 2 5/16" trailer ball mounted to the tractor drawbar. Customer supplies ball.

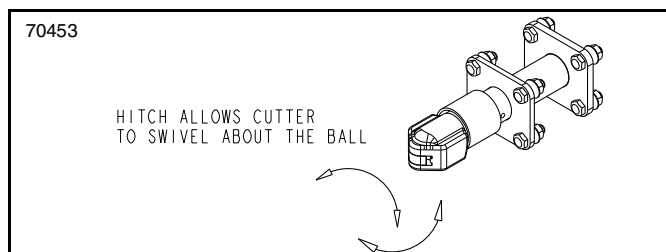

Ball Hitch
Figure 1-5

Pintle Hitch (Optional)

Refer to Figure 1-6:

The Pintle Hitch allows the cutter to swivel about the pintle connection. The pintle hitch is ideal for a drawbar hammer strap.

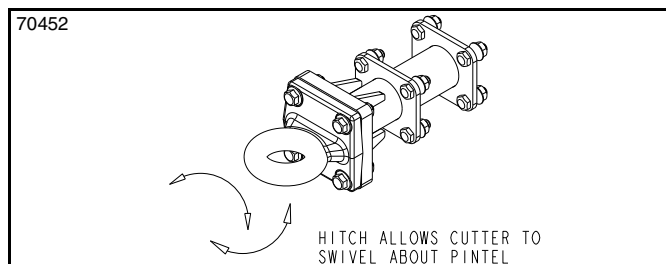

Pintle Hitch
Figure 1-6

Section 1: Assembly & Set-up

Tractor Shutdown Procedure

The following are basic tractor shutdown procedures. Follow these procedures and any additional shutdown procedures provided in your tractor Operator's Manual before leaving the operator's seat.

1. Reduce tractor engine speed to an idle.
2. If power take-off is engaged, disengage it.
3. Park tractor and implement on level, solid ground.
4. Lower implement to ground or onto solid, non-concrete support blocks.
5. Put tractor in park or set park brake, turn off engine, and remove switch key to prevent unauthorized starting.
6. Relieve all hydraulic pressure to auxiliary hydraulic lines.
7. Wait for all components to come to a complete stop before leaving the operator's seat.
8. Use steps, grab-handles and anti-slip surfaces when stepping on and off the tractor.

Hitch Assembly

NOTE: The center deck lift cylinder hose will need to be connected to a tractor before the hitch on the cutter can be rotated down for assembly.

Refer to Figure 1-7:

1. Connect center deck lift cylinder hose to a tractor. See "**Hydraulic Hook-up**" on page 19 for instructions.
2. Raise Rotary Cutter up with tractor control lever. Remove and discard shipping bracket and cotter pin from center deck cylinder (#1).
3. Keep all stroke control flip spacers (#2) in the open position, then lower center deck down until unit is fully resting on the ground.

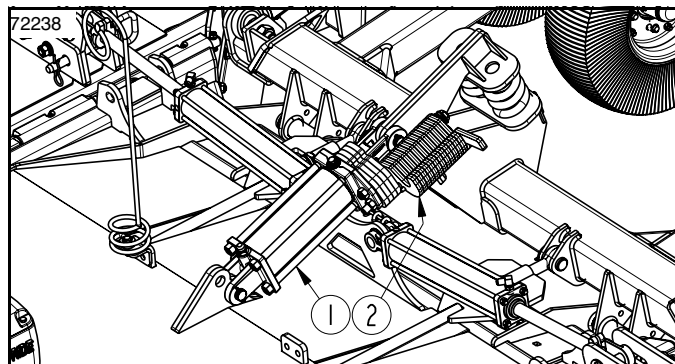

Cylinder Stroke Control Disengagement
Figure 1-7

Refer to Figure 1-8:

4. For shipping, the hitch (#2) is positioned upright and bolted in place. Before removing bolts, secure hitch (#2) with a hoist. Then remove and discard 1/2" hex whiz nuts (#4) and 1/2" bolts (#3).

5. Rotate hitch (#2) down into pulling position as shown. Install left and right leveling rods (#1) to hitch (#2) with 3/4"-10 x 4 GR8 bolts (#6), 3/4" flat washers (#5), and 3/4" nylock hex nuts (#7).
6. Tighten nylock hex nuts (#7) to where the nut and bolt are tight on the hitch. Do not overtighten bolt and collapse tongue plates.
7. Leveling rod adjustments will be made after Rotary Cutter is attached to the tractor.

Attach Park Jack

Refer to Figure 1-8:

1. Attach park jack (#9) to jack mount as shown and secure with attached pin (#8).
2. If park jack is not vertical, adjust jack angle according to "**Park Jack Angle Alignment**" on page 29.
3. Adjust jack up or down until hitch frame (#2) is at drawbar height.

Attach Spring Hose Loop

NOTE: For shipping purposes, the spring hose loop is banded to the park jack on the tongue.

NOTE: Mount the spring hose loop on the left side if the tractor remotes are on the left-hand side.

Refer to Figure 1-8:

1. Attach spring hose loop (#10) to hitch frame (#2) with 1/2"-13 x 1 1/2" GR5 bolt (#11), 1/2" flat washer (#12), and 1/2" hex whiz nut (#13).
2. Orient the spring hose loop (#10) as shown and tighten 1/2" hex whiz nut (#13) to the correct torque. Refer to the "**Torque Values Chart for Common Bolt Sizes**" on page 65.

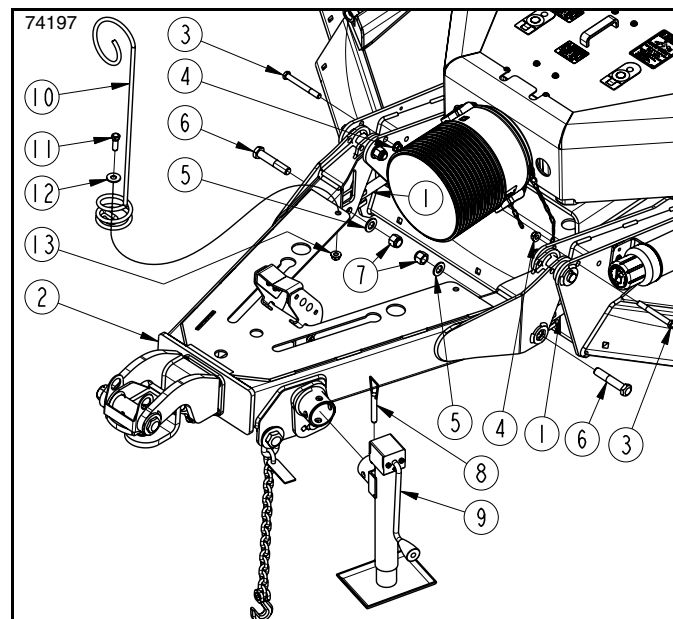

Hitch and Jack Assembly
Figure 1-8

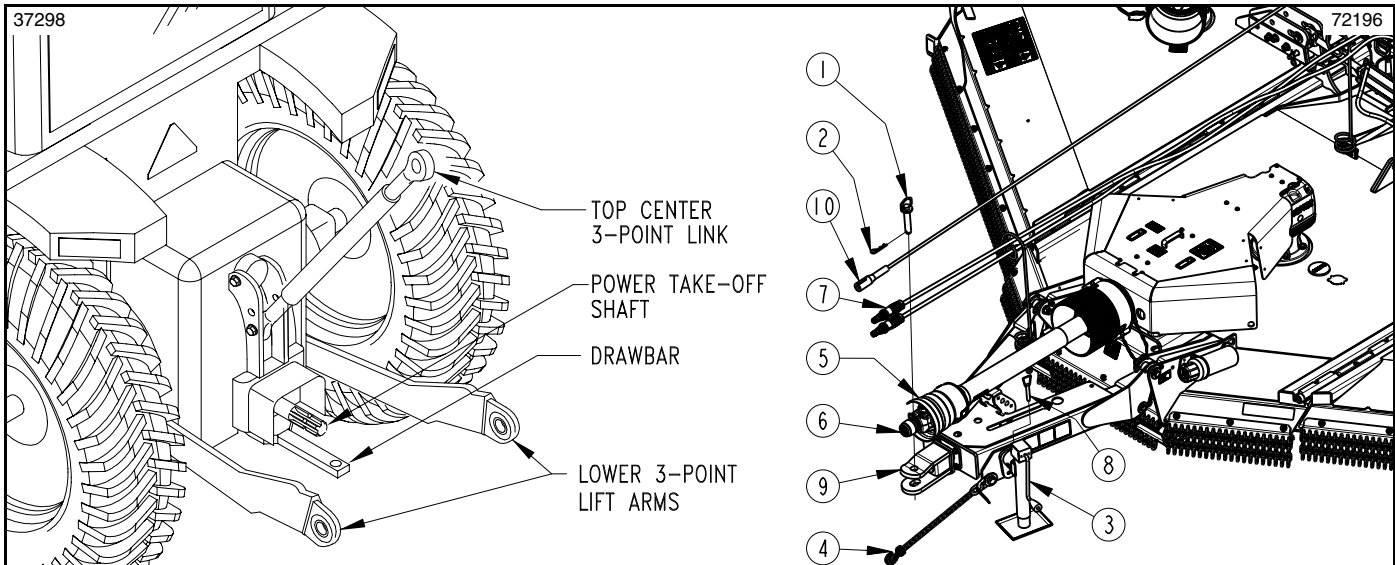

Swivel Clevis Hitch Hook-Up
Figure 1-9

Swivel Clevis Hitch Hook-up

DANGER

To avoid serious injury or death:

A crushing hazard exists while hooking-up and unhooking the implement. Keep people and animals away while backing-up to the implement or pulling away from the implement. Do not operate hydraulic controls while a person or animal is directly behind the power machine or near the implement.

WARNING

To avoid serious injury or death:

The ball detent pin must be fully inserted into the park jack with ball visible and popped out on the far side of the jack before working on or around an unhooked cutter.

Refer to Figure 1-9:

1. Make certain park jack (#3) is properly attached to the cutter hitch and secured with detent pin (#8). If park jack is not vertical, refer to “**Park Jack Angle Alignment**” on page 29.
2. Store tractor’s center 3-point link in its storage hook.
3. Start tractor and raise 3-point arms fully up.
4. Carefully back tractor to close proximity of clevis (#9).
5. Shut tractor down properly before dismounting according to “**Tractor Shutdown Procedure**” on page 15.
6. Verify tractor drawbar is adjusted correctly. Refer to “” on page 13.
7. Raise or lower park jack (#3) to align clevis (#9) with tractor drawbar. Drawbar should fit between lower and upper plates of clevis.

8. Restart tractor and continue to back tractor up to cutter hitch until hitch holes in tractor drawbar and clevis (#9) are aligned.
9. Shut tractor down properly before dismounting.

NOTE: Hitch pin (#1) and hairpin cotter (#2) are supplied by customer.

10. Attach cutter to tractor drawbar with customer supplied hitch pin (#1) and hairpin cotter (#2).
11. Lower park jack (#3) until hitch weight is supported by drawbar.

IMPORTANT: Before moving the cutter, relocate park jack by storing it on the left wing deck. Make sure the jack is stored with its base level or lower than the head to prevent water and freeze damage.

12. Relocate park jack (#3) from hitch frame to left-hand wing storage base with detent pin (#8). Ensure base of park jack is level with, or lower than the jack crank head, especially after the wings are folded up. See cover picture for correct positioning.
13. Attach hitch safety chain (#4) to the tractor. Adjust chain length to remove all slack except what is necessary to permit turning. Lock chain hook securely to the safety chain.
14. Continue with “**Hydraulic Hook-up**” on page 19.

Section 1: Assembly & Set-up

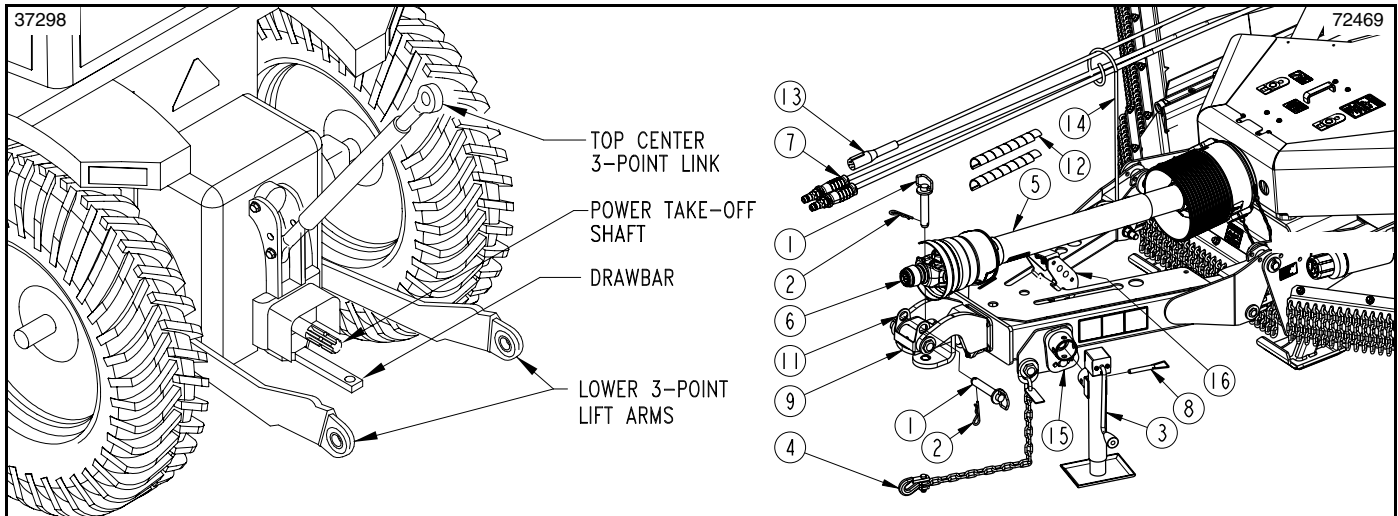

LP Performance Hitch Hook-up
Figure 1-10

LP Performance Hitch Hook-up

⚠ DANGER

To avoid serious injury or death:

A crushing hazard exists while hooking-up and unhooking the implement. Keep people and animals away while backing-up to the implement or pulling away from the implement. Do not operate hydraulic controls while a person or animal is directly behind the power machine or near the implement.

⚠ WARNING

To avoid serious injury or death:

The ball detent pin must be fully inserted into the park jack with ball visible and popped out on the far side of the jack before working on or around an unhooked cutter.

NOTE: Hitch pin (#1) and hairpin cotter (#2) are customer supplied.

Refer to Figure 1-10:

1. Make certain park jack (#3) is properly attached to the cutter hitch and secured with ball detent pin (#8).
2. Adjust park jack angle if it is not vertical. Refer to “Park Jack Angle Alignment” on page 29.
3. In order to properly align and hook-up the tractor’s drawbar to the LP Performance Hitch, clevis opening should be parallel with the drawbar. This can be accomplished by rotating clevis (#9) so that the flip hitch holder (#11) is positioned on top as shown. Insert the customer supplied hitch pin (#1) through holes in flip hitch holder (#11) as shown. Secure with hairpin cotter (#2).
4. Remove bushings in clevis (#9) if customer supplied hitch pin diameter is larger than 1". See “LP Performance Hitch Hole Size” on page 31 for instructions.
5. Store center 3-point link in the tractor’s storage hook.

6. Start tractor, raise 3-point arms fully up, and carefully back tractor within close proximity of clevis (#9).
7. Shut tractor down properly before dismounting according to “Tractor Shutdown Procedure” on page 15.
8. Verify tractor drawbar is adjusted correctly. Refer to “” dimensions on page 13.
9. Raise or lower park jack (#3) to align clevis (#9) with tractor drawbar. Drawbar should fit between lower and upper plates of clevis.
10. Restart tractor and continue to back tractor up to cutter hitch until holes in tractor drawbar and clevis hitch (#9) are aligned.
11. Shut tractor down properly before dismounting.
12. Remove hairpin cotter (#2) and hitch pin (#1) from hitch holder (#11) and rotate hitch holder down.
13. Attach cutter to tractor drawbar with hitch pin (#1) and hairpin cotter (#2) as shown.
14. Lower park jack (#3) until hitch weight is supported by tractor drawbar.

IMPORTANT: Before moving the cutter, relocate park jack by storing it on the left wing deck. Make sure the jack is stored with its base level or lower than the head to prevent water and freeze damage.

15. Relocate park jack (#3) from hitch frame to left-hand wing storage base with detent pin (#8). Ensure jack base is level with, or lower than the jack crank head, especially after the wings are folded up. See cover picture for correct positioning.
16. Attach hitch safety chain (#4) to the tractor. Adjust chain length to remove all slack except what is necessary to permit turning. Lock chain hook securely to the safety chain.
17. Continue with “Hydraulic Hook-up” on page 19.

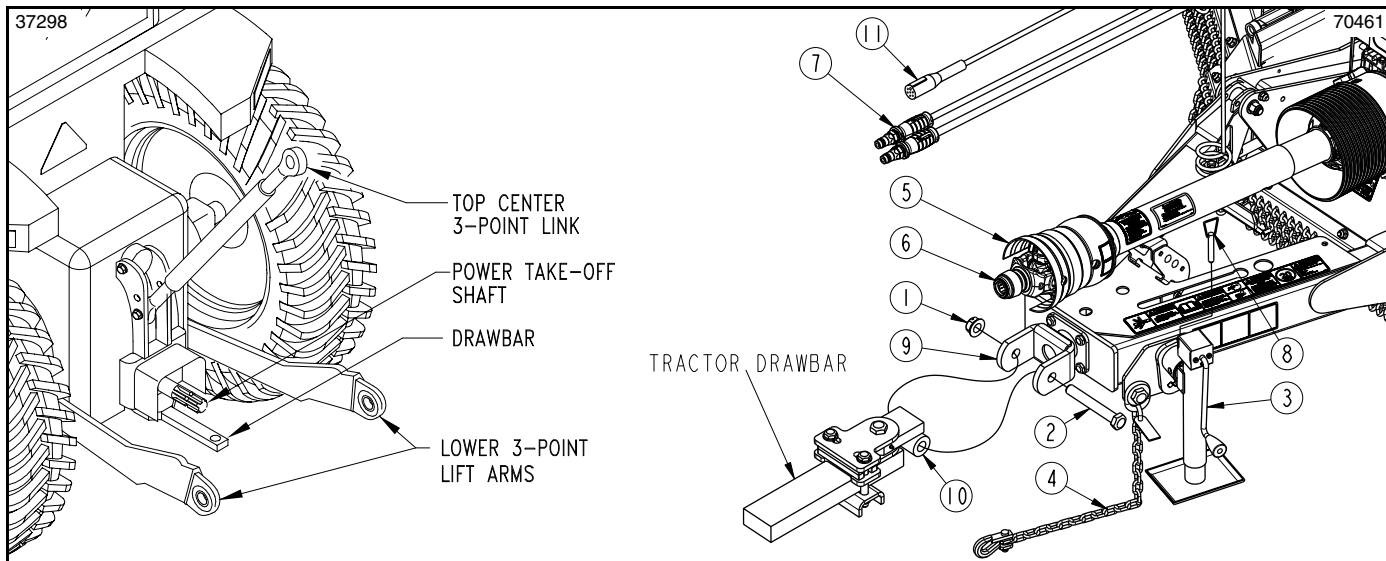

Bar-Tite Hitch Hook-up
Figure 1-11

Bar-Tite Hitch Hook-up

Attach Bar-Tite Hitch to Tractor Drawbar

Refer to Figure 1-12:

1. Insert 1" x 5 1/2" hex bolt (#1) through hitch top plate (#2), hitch bushing (#3), hitch wear plate (#4), tractor drawbar (#5), and washer (#6) as shown. Secure with 1" locknut (#7). Tighten 1" locknut snugly to remove all play and then back nut off with one-quarter turn. Do not torque 1" locknut at this time.
2. Insert two 3/4" x 6" GR5 hex bolts (#8) through 3/4" flat washers (#9), hitch top plate (#2), hitch wear plate (#4), and formed hitch support (#10) as shown. Secure with 3/4" locknuts (#11).
3. Tighten 3/4" locknuts to correct torque by referring to the **"Torque Values Chart for Common Bolt Sizes"** on page 65.
4. Remove 1" x 6 1/2" GR5 hex bolt (#12) and 1" lock nut (#13) from hitch bushing (#3). Keep bolt and locknut for reuse.

Attach Bar-Tite Hitch to Rotary Cutter

Refer to Figure 1-11:

DANGER

To avoid serious injury or death:

A crushing hazard exists while hooking-up and unhooking the implement. Keep people and animals away while backing-up to the implement or pulling away from the implement. Do not operate hydraulic controls while a person or animal is directly behind the power machine or near the implement.

WARNING

To avoid serious injury or death:

The ball detent pin must be fully inserted into the park jack with ball visible and popped out on the far side of the jack before working on or around an unhooked cutter.

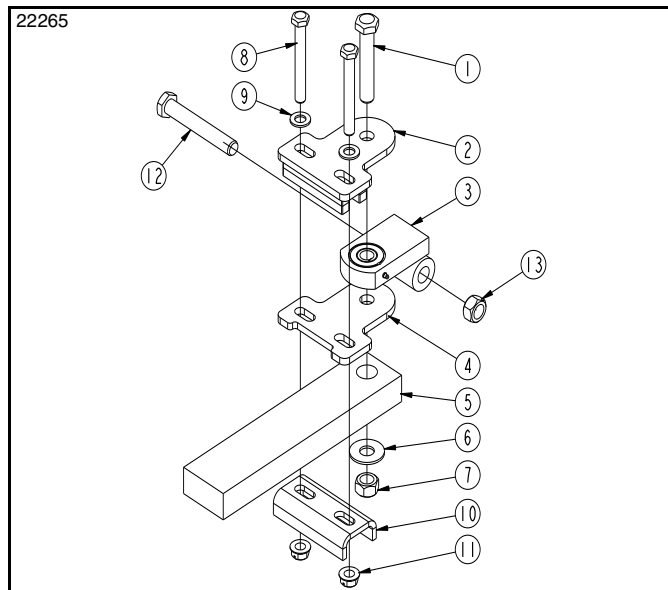

Bar-Tite Hitch Assembly to Tractor Tongue
Figure 1-12

1. Make certain park jack (#3) is properly attached to the cutter hitch and secured with detent pin (#8). If park jack is not vertical, refer to **"Park Jack Angle Alignment"** on page 29.
2. Store center 3-point link in its storage hook.
3. Start tractor, raise 3-point arms fully up, and carefully back tractor within close proximity of clevis (#9).
4. Shut tractor down properly before dismounting according to **"Tractor Shutdown Procedure"** on page 15.
5. Verify tractor drawbar is adjusted correctly. Refer to "" dimensions on page 13.
6. Raise or lower park jack (#3) to align hitch (#10) with bolt hole in swivel clevis (#9).

Section 1: Assembly & Set-up

7. Restart tractor and back up to cutter hitch until hitch bushing (#10) aligns with holes in swivel clevis (#9).
8. Shut tractor down properly before dismounting.
9. Insert 1" x 6 1/2" GR5 hex bolt (#2) through swivel clevis (#9) and hitch bushing (#10). Secure bolt with locknut (#1). Tighten locknut snug to remove all play. Do not torque 1" locknut at this time.
10. Lower park jack (#3) until hitch weight is supported by the drawbar.

IMPORTANT: Before moving the cutter, relocate park jack by storing it on the left wing deck. Make sure the jack is stored with its base level or lower than the head to prevent water and freeze damage.

11. Relocate park jack (#3) from hitch frame to left-hand wing storage base with detent pin (#8). Ensure jack base is level with, or lower than the jack crank head, especially after the wings are folded up. See cover picture for correct positioning.
12. Attach hitch safety chain (#4) to tractor. Adjust length to remove slack except what is necessary to permit turning. Securely lock chain hook to the safety chain.
13. Continue with “Hydraulic Hook-up” below.

Hydraulic Hook-up

The required number of duplex outlets on the tractor is dependent upon how the cutter is set-up. The standard cutter is equipped with three hydraulic cylinders with one in the center for lifting the cutter and one on each wing for folding the wings simultaneously. The center lift cylinder is set up for single-action (one way) operation. The wings can be set up with single-action (one way) or dual-action (both way) operation.

Each duplex outlet on your tractor can perform just one operation. One outlet is needed for lifting the cutter and one for folding the wings simultaneously. Two outlets are needed to fold the wings independently. It is highly recommended to connect the wing fold hose(s) to a duplex outlet with float capabilities and use the float when in field operation.

The black handled hose is for the lift cylinder. The red handled hose is for simultaneous fold or right hand wing fold when setup independently. The yellow handled hose is for left hand wing fold when set up independently. When set up for dual-action fold, the handles have directional arrows to identify what the hose does when charged. See “Figure 1-14”.

WARNING

To prevent serious injury or death:

Hydraulic fluid under high pressure will penetrate the skin or eyes causing a serious injury. Wear protective gloves and safety glasses or goggles when working with hydraulic systems. Use a piece of cardboard or wood rather than hands when searching for leaks. If an accident occurs, seek immediate emergency medical care or gangrene may result. DO NOT DELAY.

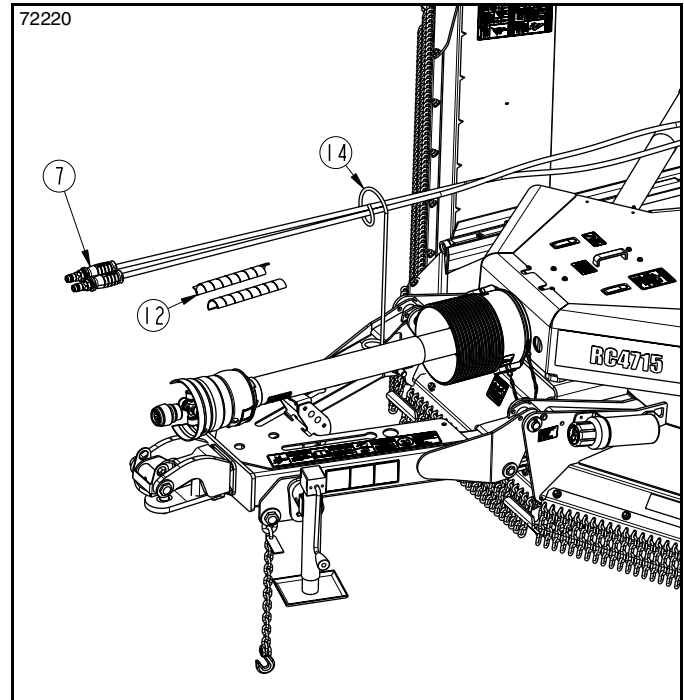

Hydraulic Hook-up (LP Performance Hitch Shown)
Figure 1-13

Refer to Figure 1-13:

1. Route hydraulic hoses (#7) through hose support loop (#14) and attach couplers to the tractor remote outlets. If tractor has a float option on one of the outlets, connect wing lift hose to that outlet and set tractor control lever for that outlet in float position before cutting.
2. Apply spiraled hose wrap (#12) to hydraulic hoses (#7) as needed to keep the hoses from pinch areas caused by raising and lowering the deck, folding the wing up and down, and while making turns with the tractor.

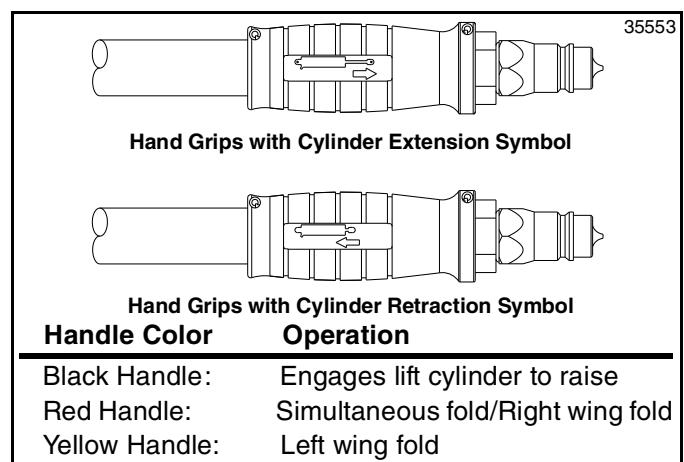

Hydraulic Hose Hand Grips
Figure 1-14

Section 1: Assembly & Set-up

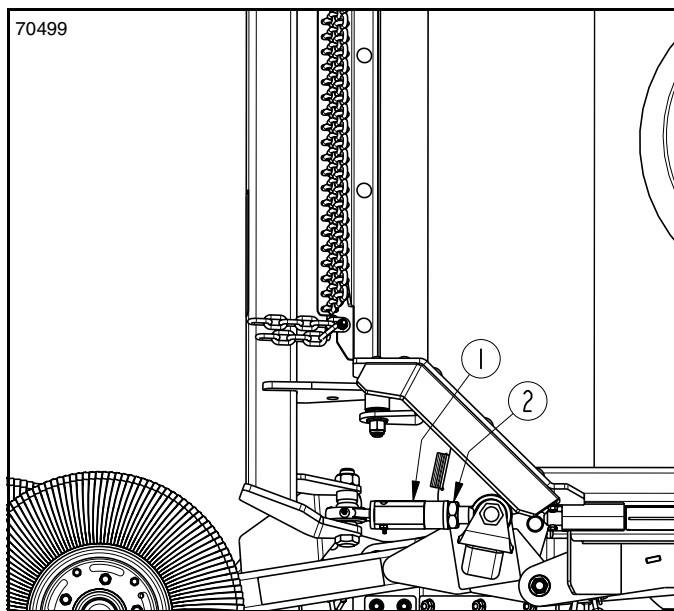

Wing Axle - Turnbuckle
Figure 1-15

Wing Axle Turnbuckle Set-up

Refer to Figure 1-15:

NOTE: The cutter is shipped with turnbuckles attached and drawn all the way in as shown in Figure 1-15.

1. Park tractor and cutter on a level surface.
2. Shut tractor down properly before dismounting according to “**Tractor Shutdown Procedure**” on page 15.
3. Loosen jam nut (#2) on turnbuckle (#1) and adjust until center of ball swivels are approximately 10 1/2" (26.7 cm) apart. Do not tighten jam nut. Final adjustment will be made later when leveling wing decks.
4. Repeat step 3 for the left wing axle.

Unfold Wings

DANGER

To avoid serious injury or death:

- Keep everyone out of the area where the wing decks will unfold. One of the wing decks can fall suddenly.
- Do not walk, stand, or allow anyone else in the area where a raised wing will fall unless the wing is securely locked in the raised position with its transport lock.

Refer to Figure 1-16:

1. Park tractor and cutter on a level surface.
2. Release any tension on transport lock pins (#2) by raising both wings up slightly.
3. Without relieving hydraulic pressure, shut tractor down properly before dismounting according to “**Tractor Shutdown Procedure**” on page 15.

4. Remove hairpin cotter (#1) from both the left and right transport pins (#2).
5. Pull transport pins (#2) from lock holes (#3) on both wings as shown.

Refer to Figure 1-17:

6. Store transport pins (#2) in storage holes (#4) as shown and secure with hairpin cotters (#1).
7. Return to the tractor, staying clear of unpinned wings.
 - a. For cutters equipped with single-action fold cylinders, restart tractor and place tractor control lever for wing cylinders to float position. Return to the cutter, staying clear of unpinned wings and carefully position yourself on the center deck. Manually push on the right wing until it starts to fall on its own. The wing should fall slowly as the hydraulic line is engaged to control the fall. If it does not fall on its own, then continue lowering the wing with tractor hydraulics. Repeat for left wing.
 - b. For cutters equipped with dual-action fold cylinders, restart tractor and lower both left and right wings with tractor hydraulic control lever until both wings are on the ground.

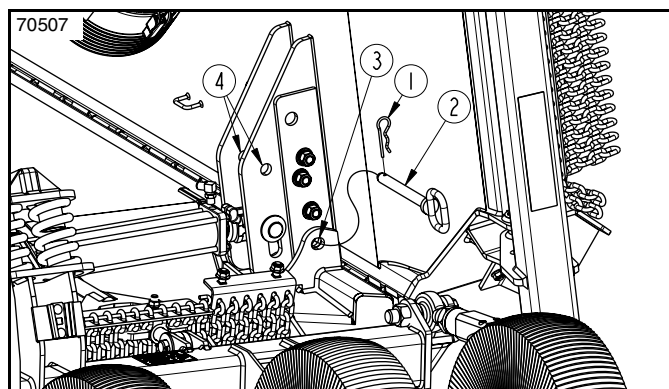

Transport Pin, Locked Position
Figure 1-16

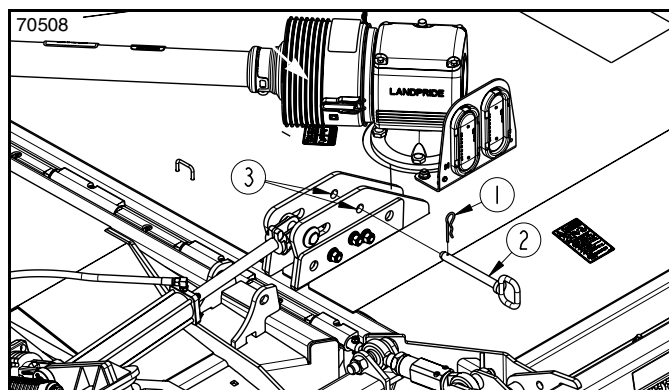

Transport Pin, Storage Position
Figure 1-17

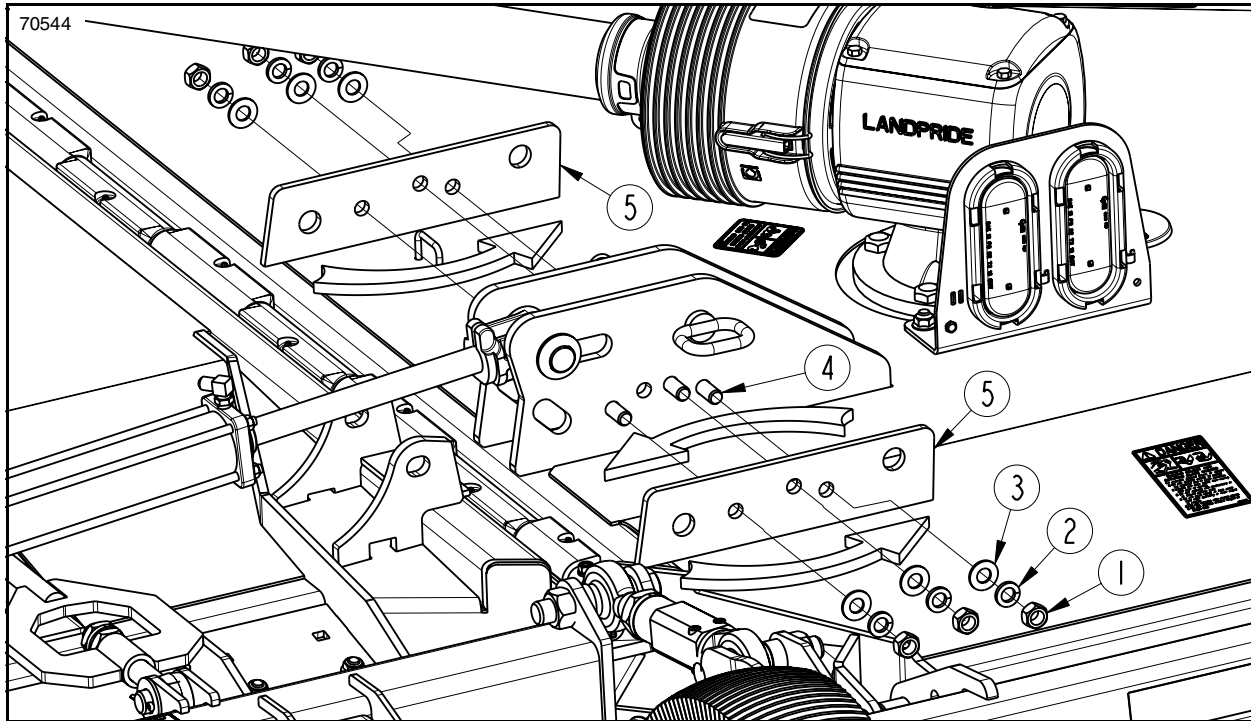

Fold Lock Lugs
Figure 1-18

Fold Lock Lugs Set-up

Refer to Figure 1-18:

If your cutter comes equipped with a dual-action fold cylinder set up, the fold lock lug plates (#5) do not need to be flipped around. See Figure 1-19.

If your cutter comes equipped with single-action fold cylinder set up, perform the following steps to flip the four fold lug plates around. See Figure 1-20.

1. With the wings down and on a level surface, remove all 5/8" hex nuts (#1), lock washers (#2), flat washers (#3) and 5/8"-11x1 3/4" bolts (#4) from both wing decks. Set hardware aside for re-use.
2. On both wing decks, flip the fold lock lugs (#5) length wise as shown.
3. Re-install 5/8" hex nuts (#1), lock washers (#2), flat washers (#3) and 5/8"-11x1 3/4" bolts (#4). Hand tighten nuts (#1).
4. Once all hardware has been reinstalled, start the tractor, and raise the wings. Then shutdown the tractor without relieving hydraulics.
5. Insert transport pins as shown in Figure 1-16 on page 20.
6. Tighten all nuts (#1) on left and right hand wing decks to correct torque. Refer to "Torque Values Chart for Common Bolt Sizes" on page 65.

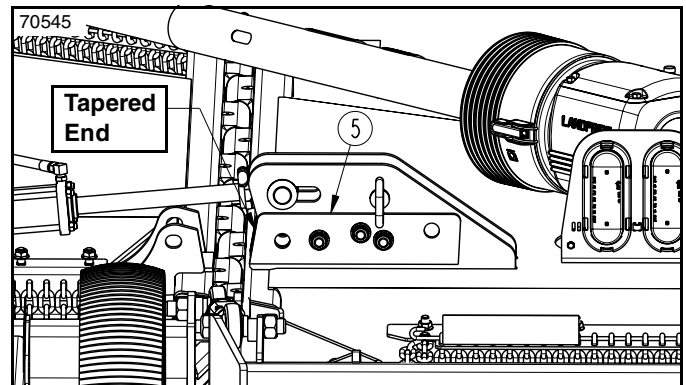

Fold Lock Lugs Set-up For Dual-Acting Cylinders
Figure 1-19

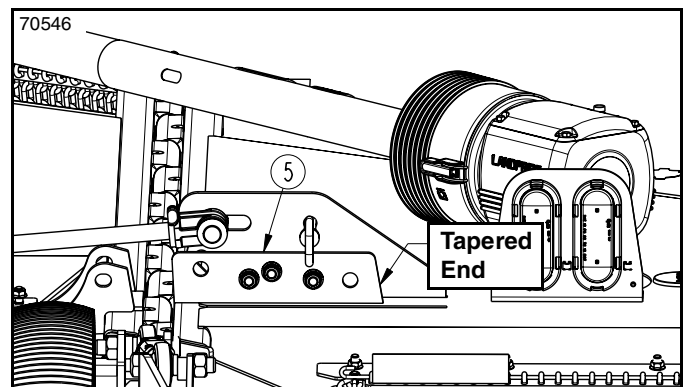

Fold Lock Lugs Set-up For Single-Acting Cylinders
Figure 1-20

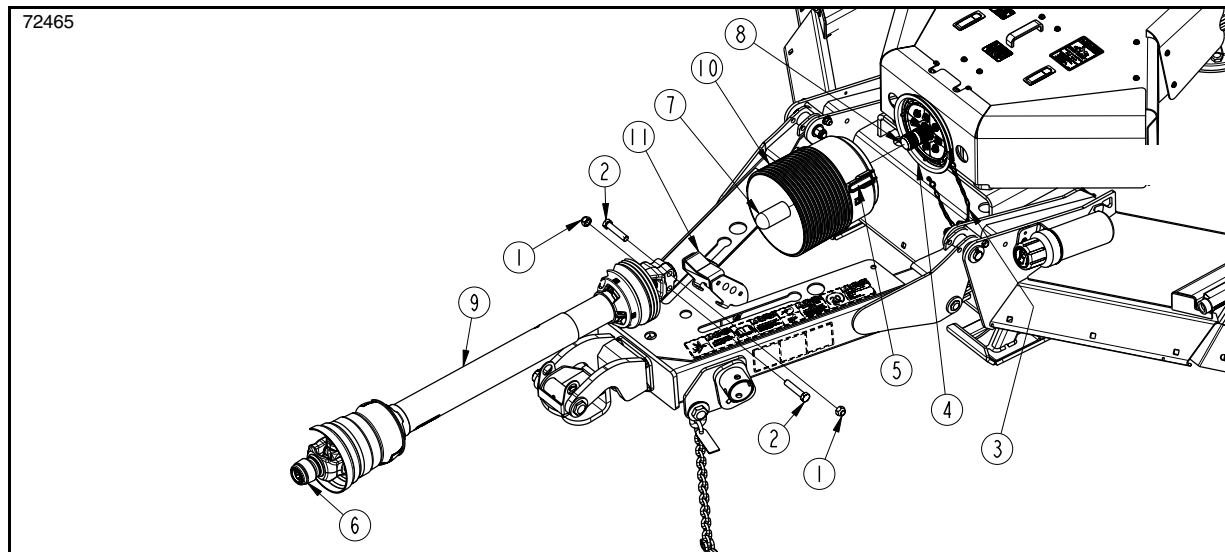

Driveline Assembly
Figure 1-21

Driveline Assembly

The main driveline type is a constant velocity, with or without overrunning clutch. Pull-collar and bolted couplers are used to secure the driveline to the tractor and implement gearbox, respectively.

DANGER

To prevent serious injury or death:

Make certain driveline yokes are securely fastened at each end. A loose yoke can work free allowing the driveline to rotate uncontrollably.

IMPORTANT: The driveline must be lubricated before putting it into service. Refer to “**Lubrication Points**” on page 54.

NOTE: Wings must be lowered before removing the driveline from its shipping location. See “**Unfold Wings**” on page 20.

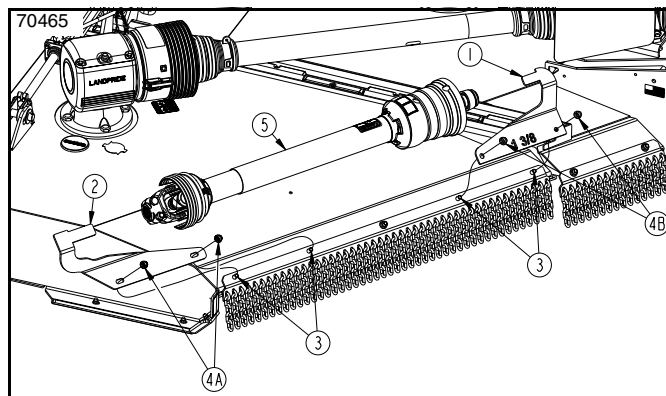

Remove Main Driveline from Shipping Position
Figure 1-22

Refer to Figure 1-21:

6. Unsnap latches (#5) on both sides of gearbox shield (#10) and remove shield.
7. Remove and discard rubber shaft protector (#7) from splitter gearbox shaft (#8).
8. Remove locknuts (#1) and bolts (#2) from bolted coupler end of driveline (#9).
9. Insert bolted coupler end of driveline (#9) through gearbox shield (#10) and attach to gearbox input shaft (#8) with removed bolts (#2) and locknuts (#1). Tighten locknuts to the correct torque.
10. Collapse driveline (#9) by pushing tractor end of driveline toward splitter gearbox (#8).
11. Rotate driveline hanger (#11) up and support driveline (#9) on hanger. Final adjustments to hanger will be made later after tractor hook-up.
12. Return gearbox shield (#10) to mounting plate (#4) and secure with latches (#5).
13. Check safety chain (#3). Make sure it is latched to mounting plate (#4) and gearbox shield (#10).

Refer to Figure 1-22:

1. Remove hex whiz nuts (#4A), carriage bolts (#3), and shipping bracket (#2). Discard shipping bracket.
2. Slide driveline (#5) off end of shipping bracket (#1). Set driveline aside for attaching to splitter box later.
3. Reinsert 1/2-13x1 1/4 GR5 carriage bolts (#3) and secure with hex whiz nuts (#4A). Tighten whiz nuts to the correct torque. Refer “**Torque Values Chart for Common Bolt Sizes**” on page 65.
4. Remove hex whiz nuts (#4B), carriage bolts (#3), and shipping bracket (#1). Discard shipping bracket.
5. Reinsert carriage bolts (#3) and secure with hex whiz nuts (#4B). Tighten whiz nuts to the correct torque.

Section 1: Assembly & Set-up

Driveline Hook-up to Tractor

⚠ DANGER

To avoid serious injury or death:

- Do not engage power take-off while hooking-up or unhooking the driveline, or while someone is standing near the driveline. A person's body and/or clothing can become entangled in the driveline.
- Tractor power take-off shaft shield, driveline shields, and gearbox shaft shields must be installed and in good working condition to avoid driveline entanglement and projectiles flying off of the driveline.
- Do not use a power take-off adapter. The adapter will increase strain on the tractor's power take-off shaft causing possible damage to shaft and driveline. It will also defeat the purpose of the tractor's power take-off shield.

⚠ WARNING

To avoid serious injury or death:

- Always disengage power take-off, put tractor in park or set park brake, shut tractor engine off, remove ignition key, and wait for blades to come to a complete stop before dismantling tractor.
- Some tractors are equipped with two power take-off speeds. Be certain your tractor's power take-off shaft is set-up to operate the implement at its rated power take-off speed. Do not exceed implement's rated power take-off speed. Excessive speed can damage drive components, cutter blades, and/or increase the risk of a thrown object hazard. RC models are rated for 540 rpm and RCM models are rated for 1000 rpm.
- Make certain driveline yokes are securely fastened at each end. A loose yoke can work free allowing the driveline to rotate uncontrollably.

Refer to Figure 1-23:

1. If needed, collapse driveline (#5) by pushing tractor end of driveline against splitter gearbox.
2. Pull back on yoke locking collar (#6) and slide yoke onto tractor power take-off shaft.
3. Release locking collar (#6) and continue to push outer yoke onto tractor power take-off shaft until locking collar snaps in place.
4. Both yoke ends of driveline (#5) should be moved back and forth to ensure they are secured. Reattach yoke end if it is loose.

IMPORTANT: Always rotate driveline hanger down after hook-up to prevent driveline damage.

5. Rotate driveline hanger (#1) down.
6. If park jack (#7) is attached to the hitch, lower park jack until hitch weight is supported by drawbar.

7. Relocate park jack (#7) from hitch frame and attach it to the left-hand wing storage base with detent pin (#4). Ensure base of park jack is level with, or lower than the jack crank head, especially after the wings are folded up. See cover picture for correct positioning.

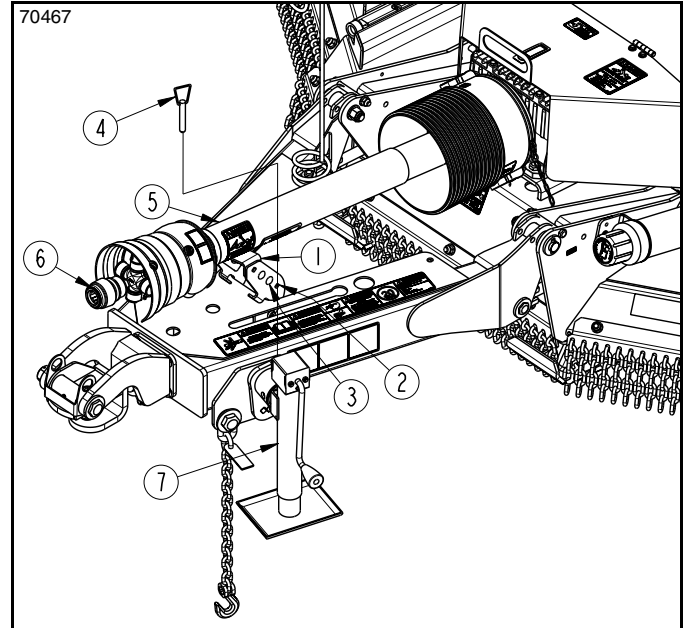

Driveline Hook-up
Figure 1-23

Section 1: Assembly & Set-up

Driveline Hanger Adjustment

Refer to **Figure 1-24**:

1. Move tractor control lever to extend hydraulic lift cylinder (#1) until pressure against flip spacers (#2) has been eliminated.
2. Without relieving hydraulic pressure, shut tractor down properly before dismounting according to “**Tractor Shutdown Procedure**” on page 15.

WARNING

To prevent serious injury or death: Stay clear from underneath the cutter and directly behind transport tires. The cutter could fall suddenly causing the decks to lower and tires to roll back.

3. Move stroke control flip spacers (#2) from closed position to their open position.
4. Start tractor and lower cutter until front skid shoes are resting on the ground or on solid, non-concrete support blocks.
5. Shut tractor down properly before dismounting.
6. Close stroke control flip spacers (#2) as needed to support wheels at this position.

Refer to **Figure 1-25**:

7. With driveline (#2) attached to tractor, rotate driveline hanger (#1) up as shown.
8. If gap between driveline (#2) and driveline hanger (#1) is too wide to safely rest driveline on hanger when not attached to tractor, loosen all four hex nuts (#6) on carriage bolts (#3) and adjust driveline hanger (#1) up until there is a small gap between driveline (#2) and driveline hanger (#1).
9. If gap between driveline (#2) and driveline hanger (#1) is still too wide, adjust hanger by removing all four carriage bolts (#3), and all its corresponding hardware.
10. With hardware removed, adjust driveline hanger (#1) to achieve appropriate gap distance from underside of driveline, and reinsert all four carriage bolts (#3) into appropriate square holes (#7).
11. Secure all four carriage bolts (#3) with recently removed flat washers (#4), lock washers (#5) and hex nuts (#6). Thread hex nuts so they are snug against lock washer, but do not tighten at this time.
12. Pivot driveline hanger (#1) up and down to make sure driveline hanger does not make contact with driveline (#2). If needed, readjust hanger down until it misses the driveline (#2).
13. Tighten all four 3/8"-16 GR5 carriage bolts (#3) to the correct torque. Refer to the “**Torque Values Chart for Common Bolt Sizes**” on page 65.

IMPORTANT: Always rotate driveline hanger down before moving cutter to prevent damage to driveline.

14. When adjustments are complete, rotate driveline hanger (#1) down away from driveline.

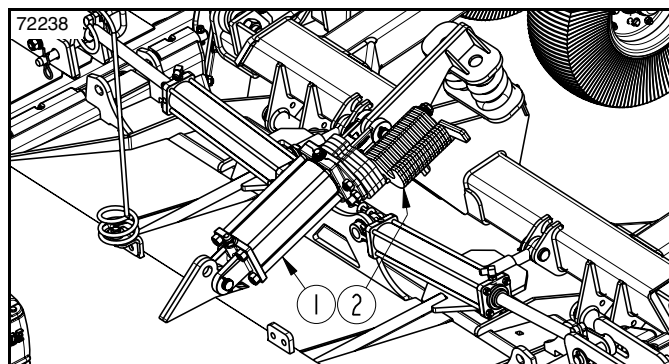

Hydraulic Lift Cylinder and Stroke Control Flip Spacers
Figure 1-24

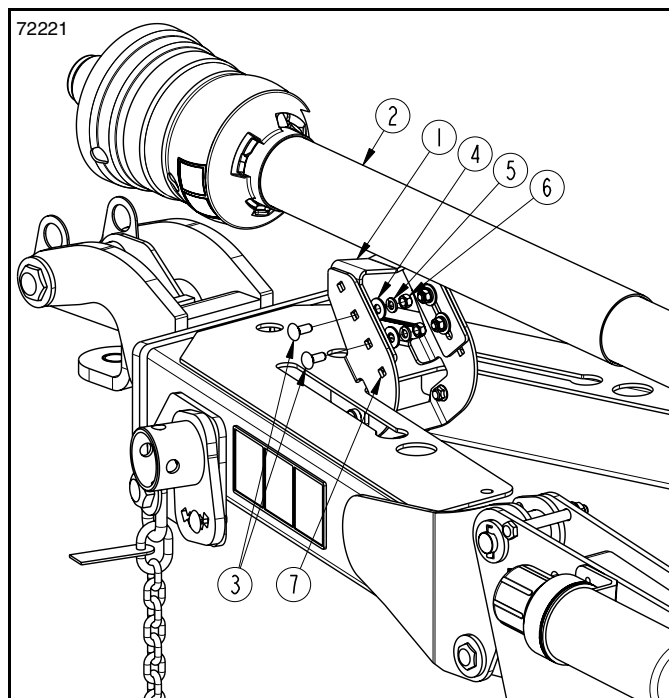

Driveline Hanger Adjustment
Figure 1-25

Driveline Clearance Check

Refer to **Figure 1-26 on page 25**:

Check driveline for adequate clearance under all ranges of cutter height.

1. With driveline attached to the tractor and all stroke control flip spacers (#6) in open position, slowly raise and lower cutter to its upper and lower limits while observing clearances between hitch and driveline.
2. Adjust tractor drawbar height and/or length if driveline interferes. See **Figure 1-1** on page 13 for correct drawbar dimensions.
3. It may be necessary to purge lift cylinder, wing cylinder, and hydraulic hoses of trapped air if operation is sluggish. Cycle cylinders back and forth several times to purge air from them. For additional details, see “**Purge Hydraulic System**” on page 25.

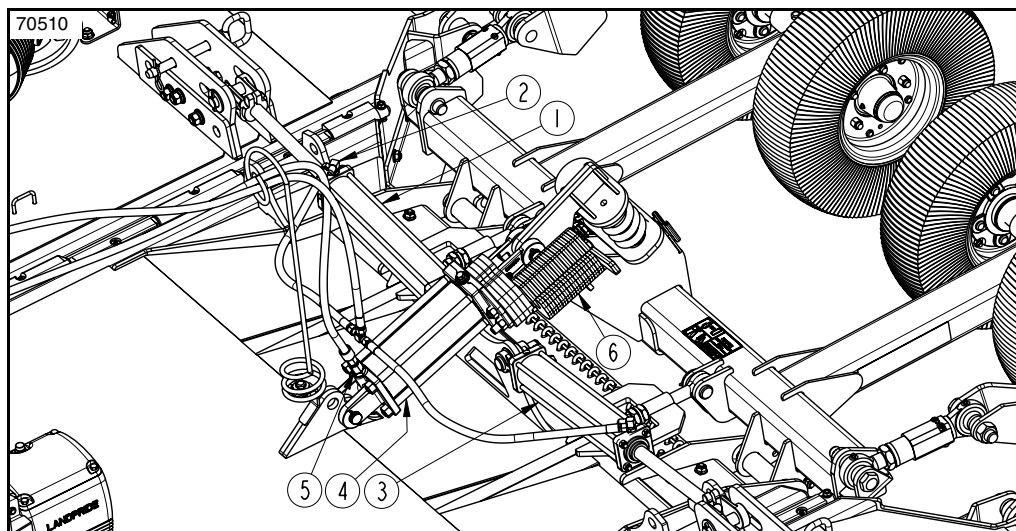

Purge Wing & Center Deck Cylinders

Figure 1-26

Purge Hydraulic System

DANGER

To prevent serious injury or death:

Never remove or install a folding wing cylinder with cylinder rod retracted and wing folded-up. The wing is unstable without its folding cylinder and can suddenly fall. Also, air trapped in a new or repaired cylinder will drop the wing suddenly when lowering the wing. Either situation can render the cutter inoperable and cause serious bodily injury or death.

WARNING

To prevent serious injury or death:

Be sure center and wing decks are lowered to the ground and all hydraulic pressure is relieved before disconnecting any hydraulic lines or fittings to purge the hydraulic system.

Wing Fold Cylinder

Refer to Figure 1-26:

1. Lower center deck until it is supported by stroke control flip spacers (#6) on hydraulic cylinder (#4).
2. Lower wing decks until they rest on the ground.
3. Shut tractor down properly before dismounting according to “**Tractor Shutdown Procedure**” on page 15. Now move tractor control levers back and forth to relieve all hydraulic pressure.
4. Slightly loosen hydraulic hose fitting (#2) on right-hand wing cylinder (#1) to allow air to escape.
5. Restart tractor and slowly activate tractor control lever to retract wing cylinder (#1), and to purge trapped air from the hydraulic system.
6. Once all air has been purged from hydraulic system, properly shutdown tractor once more.
7. Tighten hose fitting (#2) on right-hand wing cylinder (#1).
8. Repeat steps 4-7 to purge left-hand wing cylinder (#3).

Deck Lift Cylinder

Refer to Figure 1-26:

1. Move all hydraulic stroke control flip spacers (#6) to open position, then proceed to lower center deck.
2. Shut tractor down properly before dismounting according to “**Tractor Shutdown Procedure**” on page 15. Now move tractor control levers back and forth to relieve all hydraulic pressure.
3. Slightly loosen hydraulic hose fitting (#5) on deck lift cylinder (#4) to allow air to escape.
4. Restart tractor and slowly activate tractor control lift lever to extend lift cylinder (#4) and to purge trapped air from the hydraulic system.
5. Now, shut tractor down properly again.
6. Tighten hose fitting (#5) on lift cylinder (#4).

Section 1: Assembly & Set-up

Hook-up LED Lights

Refer to Figure 1-27:

The lead wiring harness (#13) is equipped with a 7-pin plug for connecting to the tractor's 7-pin electrical outlet shown in Figure 1-28.

1. Route lead wire harness (#13) through spring hose loops (#14).
2. Connect plug on lead wire harness (#13) to the tractor's 7-pin electrical outlet.
3. It is best to have a second person verify the lights are operating. Start tractor and operate lights as follows:
 - a. Turn on head lights to verify red lights illuminate.
 - b. Turn on flasher lights to verify amber lights are blinking on and off.

Refer to Figure 1-29:

4. If the lights did not operate properly, recheck hook-up of enhance module and wire harnesses. Make necessary changes and repeat step 3 above.
 - a. Make sure connector (#9R) with a red wire is connected to end labeled "ENHANCER" of wire harness (#8R), for LED light on implement's right side.
 - b. Make sure connector (#9L) with a yellow wire is connected to end labeled "ENHANCER" of wire harness (#8L), for LED light on implement's left side.
 - c. Make sure connector on the lead wire harness (#13) is connected to connector (#9C) on enhancer module (#9).
 - d. Ensure that the 7-pin plug of 15' lead wire harness (#13) is properly seated inside 7-pin electrical outlet on tractor (not shown).
5. Check wire harness routing to make sure wires will not be pinched as wing decks are folded and unfolded and while raising and lowering cutter height.
6. Secure harness in place with spiral hose wrap (#12) and add cable ties as needed.

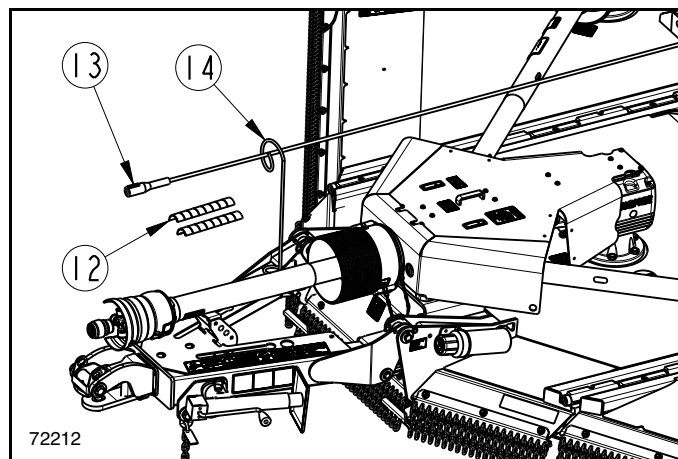

LED Hookup
Figure 1-27

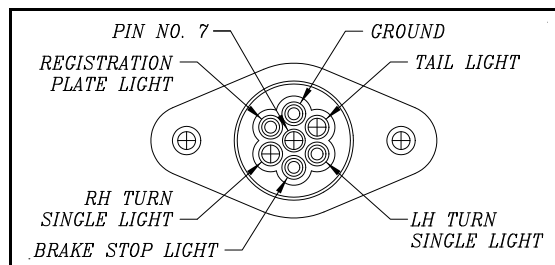

Tractor 7-Pin Electrical Outlet
Figure 1-28

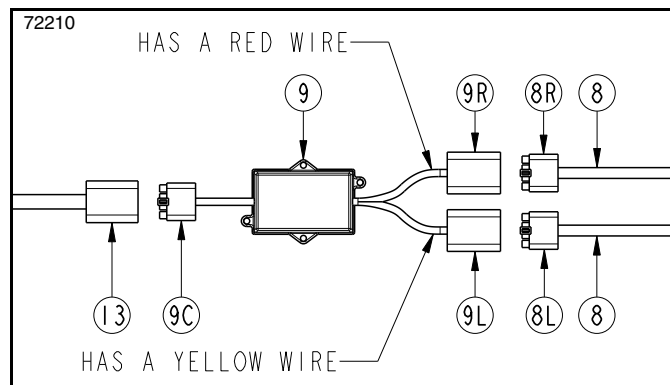

Enhance Module Wire Connections
Figure 1-29

Remove Shipping Lugs

Refer to Figure 1-30:

Tie down lugs are installed on the rear two corners of the center deck for shipping purposes only. They should be removed and discarded before cutter is put into use.

Remove and discard both shipping lugs (#1) and attaching hardware (#2 & #3).

NOTE: Some center axle options may have the shipping lugs permanently integrated into them.

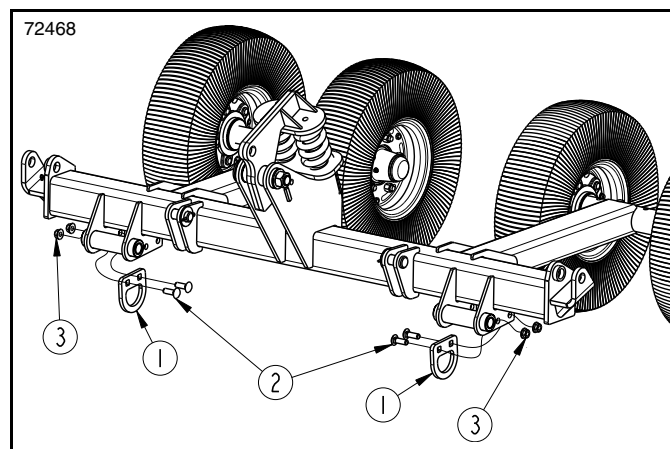

Rear Shipping Lug Removal
Figure 1-30

Section 1: Assembly & Set-up

Unhook Rotary Cutter

⚠ DANGER

To prevent serious injury or death:

Do not walk, stand, or allow anyone else in the area where a raised wing will fall unless the wing is securely locked in the raised position with its transport lock.

⚠ WARNING

To prevent serious injury or death:

Stay clear from underneath the cutter and directly behind transport tires. The cutter could fall suddenly causing the decks to lower and tires to roll back.

Refer to Figure 1-31:

1. See “**Long-Term Storage**” on page 53 when storing the cutter for long periods and at end of the season.
2. If power take-off is engaged, reduce tractor engine speed to an idle and then disengage power take-off.
3. Park cutter on a level, hard surface. Place tractor gear selector in park or set park brake.
4. Wait for blades to come to a complete stop, then raise the cutter up and fold wings up to transport position.
5. Without relieving hydraulics, shut tractor off according to “**Tractor Shutdown Procedure**” on page 15.
6. Remove hairpin cotter (#1) from transport pin (#2) and remove the transport pin (#2) from storage holes (#4).
7. Insert transport pin (#2) through wing lock hole (#3) and secure it with hairpin cotter (#1).

Refer to Figure 1-32:

8. Move all flip spacers (#2) to the open position.
9. Start tractor and lower cutter until front skid shoes are resting on the ground or on solid, non-concrete support blocks.
10. Without relieving hydraulics, shut tractor down properly before dismantling according to “**Tractor Shutdown Procedure**” on page 15.
11. Close stroke control flip spacers as needed to support wheels at this position.
12. Move hydraulic control levers back and forth to release all hydraulic pressures at the couplers.
13. Unhook hydraulic hoses (#7) from tractor duplex outlets. Insert couplers through hole (A) on the hitch frame and slide them down the slot as shown to keep couplers out of the dirt. See **Figure 1-33** on page 27.
14. Unhook wire harness (#13) from tractor outlet. Insert wire harness through hole (B) on the hitch frame with connector hanging down to keep moisture out. See **Figure 1-33** on page 27.

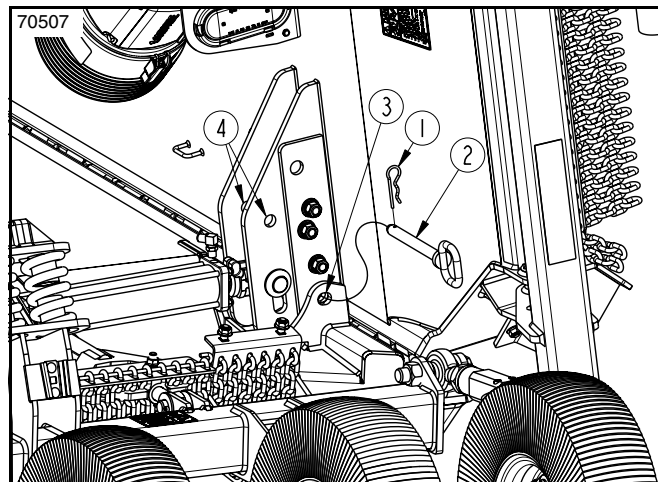

Transport Pin, Locked Position
Figure 1-31

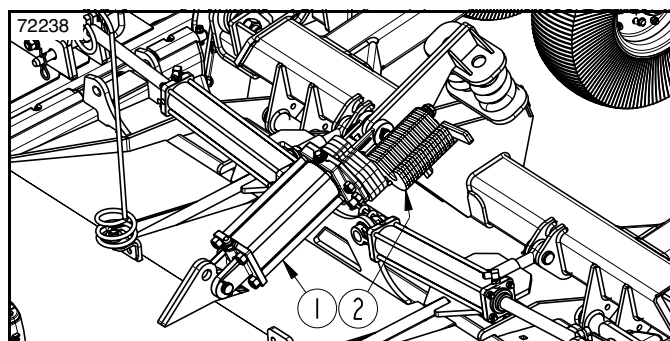

Hydraulic Lift Cylinder and Stroke Control Flip Spacers
Figure 1-32

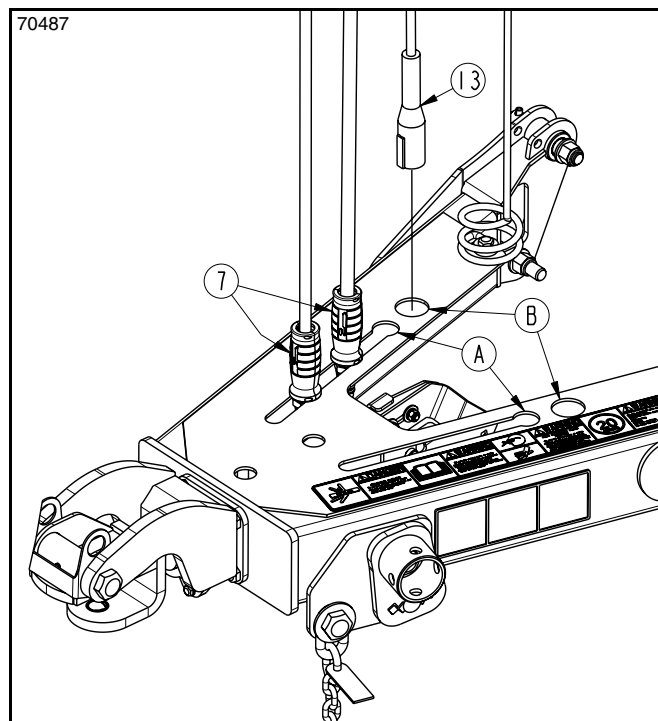

Hydraulic Couplers & Wire Harness Storage
Figure 1-33

Section 1: Assembly & Set-up

Refer to Figure 1-34:

15. Relocate park jack (#3) from the wing mount to jack mount (#15) as shown. Fully insert detent pin (#8) in jack mount (#15) to secure the park jack.
16. If needed, realign park jack (#3) to be vertical. Refer to **“Park Jack Angle Alignment”** on page 29.
17. Unhook hitch safety chain (#4) from tractor.
18. Rotate driveline hanger (#16) up to position shown.
19. Pull back on locking collar (#6) and pull driveline (#5) from tractor power take-off shaft.
20. Collapse driveline (#5) by pushing tractor end of driveline toward the splitter gearbox. Store driveline on hanger (#16).
21. Adjust park jack (#3) as needed to raise cutter hitch off the tractor drawbar.
22. Remove connecting hitch pin or bolt as follows:
 - a. **For LP Performance Hitch, See Figure 1-34:**
Remove hairpin cotter (#2) and hitch pin (#1).
 - b. **For Swivel Clevis Hitch, See Figure 1-35:**
Remove hairpin cotter (#2) and hitch pin (#1).
 - c. **For Bar-Tite Hitch, See Figure 1-36:**
Remove locknut (#1) and bolt (#2).
23. Restart tractor and slowly drive tractor forward several feet.
24. Shut tractor down properly before dismounting according to **“Tractor Shutdown Procedure”** on page 15.
25. Lower park jack until cutter is resting on its front skid shoes.
26. Replace connecting pin/bolt as follows:
 - a. **For LP Performance Hitch, See Figure 1-34:**
Rotate clevis (#9) horizontal and flip hitch holder (#11) up so that its holes are on top as shown. Insert hitch pin (#1) through holes in hitch holder (#11). Secure with hairpin cotter (#2).
 - b. **For Swivel Clevis Hitch, See Figure 1-35:**
Insert connecting pin (#1) in clevis (#9) and secure with hairpin cotter (#2).
 - c. **For Bar-Tite Hitch, See Figure 1-36:**
Insert bolt (#2) through hitch (#9) and screw lock nut (#1) onto bolt (#2) with several turns.

Relocate SMV Sign

Refer to Figure 4-8 on page 41:

1. Remove SMV sign (#1) from the mounting bracket on the back of the cutter.
2. Reinsert SMV Sign in the mounting bracket on the back of the tractor.

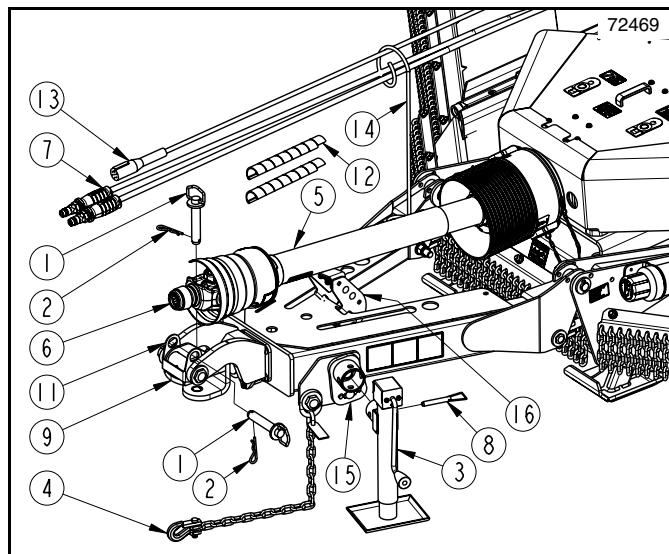

Unhook LP Performance Hitch
Figure 1-34

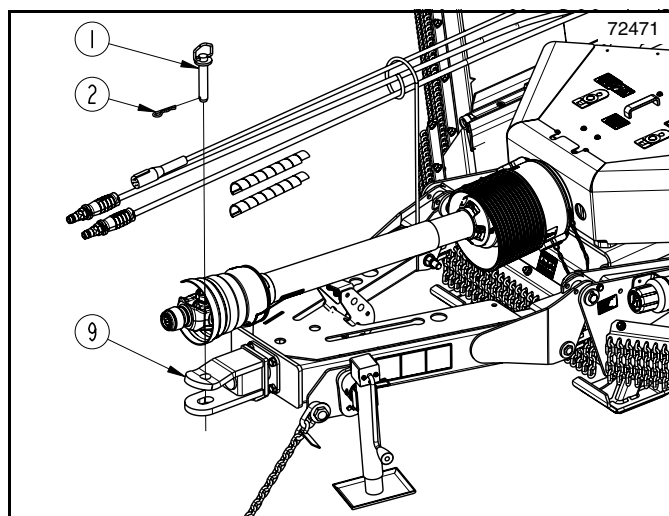

Unhook Swivel Clevis Hitch
Figure 1-35

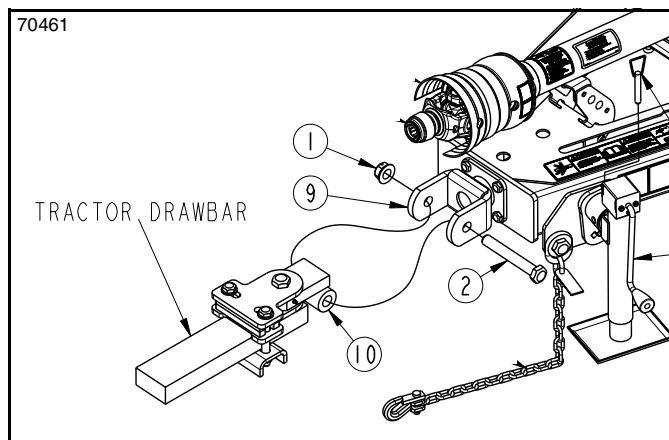

Unhook Bar-Tite Hitch
Figure 1-36

Section 2: Adjustments

Park Jack Angle Alignment

Refer to Figure 2-1:

The jack mount angle should be adjusted to position the park jack vertical while supporting the cutter hitch. This angle will vary depending on the number of stroke control flip spacers closed on the lift cylinder rod.

NOTE: Refer to decal (#6) and instructions below for jack alignment and torque value instructions.

NOTE: If cutter is not hitched to a tractor, place solid, non-concrete support blocks under the front skid shoes to support cutter while aligning park jack vertically.

1. With cutter hitched to a tractor, lower cutter to storage height.
2. Shut tractor down properly before dismounting according to “**Tractor Shutdown Procedure**” on page 15.
3. Install park jack (#7). See “**Attach Park Jack**” on page 15. Check jack angle. If jack is not vertical, proceed with step 4 below.
4. Remove hex nut (#3), lock washer (#5) and carriage bolt (#2).
5. Loosen 1" hex nut (#4). Do not remove.
6. Rotate jack mount (#1) to align jack as near vertical as possible.
7. Replace 1/2"-13 x 1 1/2" GR5 carriage bolt (#2) and secure with lock washer (#5) and hex nut (#3). Tighten hex nut to the correct torque.
8. Tighten 1" hex nut (#4) to 645 ft-lbs (874.4 N·m).
9. If moving cutter, skip to step 10. If unhooking cutter, see “**Unhook Rotary Cutter**” on page 27 for detailed instructions.
10. If cutter is to be moved, relocate park jack (#7) from hitch frame to left-hand wing storage base. Make sure base of park jack is level with or lower than the head, especially after the wings are folded up. See cover picture for correct positioning.

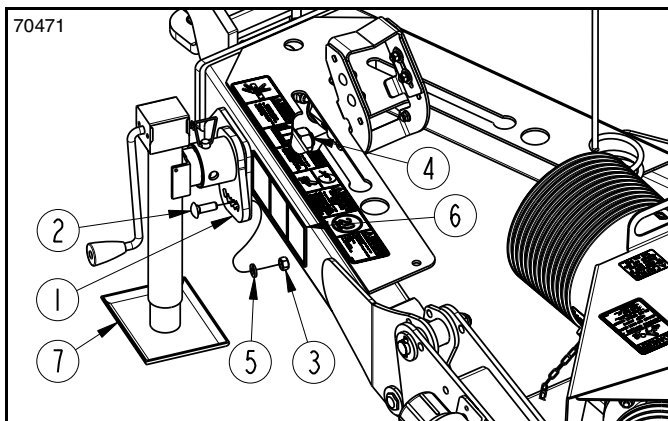

Park Jack Angle Alignment
Figure 2-1

Lift Cylinder Adjustment

Refer to Figure 2-3 on page 30:

To get best range of motion, put lift cylinder (#2) in bottom hole (as shown) when cutter is supplied with 21" to 26" tires. Put the lift cylinder (#2) in the top hole (A) when the cutter is supplied with 29" tires. When supplied with larger tires, overall ground clearance can be increased by putting the lift cylinder (#2) in the bottom hole (as shown), but lower cutting height ranges will be sacrificed.

WARNING

To prevent serious injury or death:

Stay clear from underneath the cutter and directly behind transport tires. The cutter could fall suddenly causing the decks to lower and tires to roll back.

1. Park tractor and cutter on a level surface.
2. Fully extend deck lift cylinder (#2) and fold cylinders to lower the wings.
3. Without relieving hydraulic pressure, shut tractor down properly before dismounting, according to “**Tractor Shutdown Procedure**” on page 15. Place solid, non concrete support blocks or jack stands under the four corners of the center deck.
4. Move stroke control flip spacers to open position.
5. Return to tractor seat and start the tractor. Lower center deck onto solid, non concrete support blocks. Shut tractor down properly before dismounting.
6. Remove hairpin cotter and hitch pin (#6) on both ends of cylinder.
7. If moving from hole (A) to bottom hole, measure and note the distance between the bottom hole and cylinder hole on axle. Over a bucket or oil catch, loosen hose fitting to drain oil and retract cylinder to length of noted measurement. Tighten hose fitting, clean cylinder and dispose of oil properly.
8. Reposition hydraulic cylinder to the desired mounting hole, reinsert hitch pin (#6) and secure with hairpin cotter.
9. With jack or overhead lift, lift the rear axle to align with rod end of cylinder (#2) and reinsert hitch pin and secure with hair pin. Remove jack or lift straps.
10. Return to tractor and fully extend center deck lift cylinder to raise the deck up.
11. Without relieving hydraulics, shut tractor down properly before dismounting. Close stroke control flip spacers and remove support blocks from under the four corners of the center deck.

Section 2: Adjustments

Level Cutter Decks

These adjustments should be made with your cutter hooked to the tractor that will be operating the unit or to a tractor having the same drawbar height.

Level Center Deck

Refer to **Figure 2-2** & **Figure 2-3**

1. With cutter attached to a tractor, disengage power take-off, and park on a level, hard surface. Place tractor gear selector in park or set park brake.
2. Using hydraulic lift, adjust center deck height so that front skid shoes (#2) are 2 to 3 inches above ground.
3. Wait for blades to come to a complete stop and then fold wings up to transport position.
4. Shut tractor down properly before dismounting according to “**Tractor Shutdown Procedure**” on page 15.
5. Lock wings in the up position with the transport pins. See “**Transport Pins**” on page 34 for instructions.

IMPORTANT: See **Figure 2-3**. Loosening adjusting nuts (#3) will lengthen leveling rods and lower front of cutter. Tightening adjusting nuts (#3) will shorten leveling rods and raise front of cutter.

6. On both sides of center deck, there are continuous hinges (#1). Measure distance from bottom of hinges to ground at the front and back. They should be equal distance off the ground at the back and 1" (2.5 cm) closer to the ground at the front.

NOTE: 1" (2.5 cm) measurement can be lowered or raised depending on cutting conditions.

If continuous hinges are too high at the front:

- a. Loosen jam nuts (#5) several turns.
- b. Unscrew adjusting nuts (#3) an equal amount to lower front of cutter until both hinges are 1" lower in the front than in the back.

If continuous hinges are too low at the front:

- a. Loosen jam nuts (#5).
- b. Tighten adjusting nuts (#3) an equal amount to raise front of cutter until both hinges are 1" lower in the front than in the back.

7. Be sure left and right leveling rods have equal amounts of tension and then retighten jam nuts (#5) against lock washers (#4) and adjusting nuts (#3).

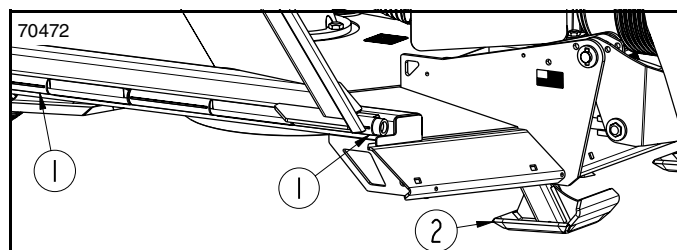

Front Skid Position (Chain Guards Removed For Clarity)
Figure 2-2

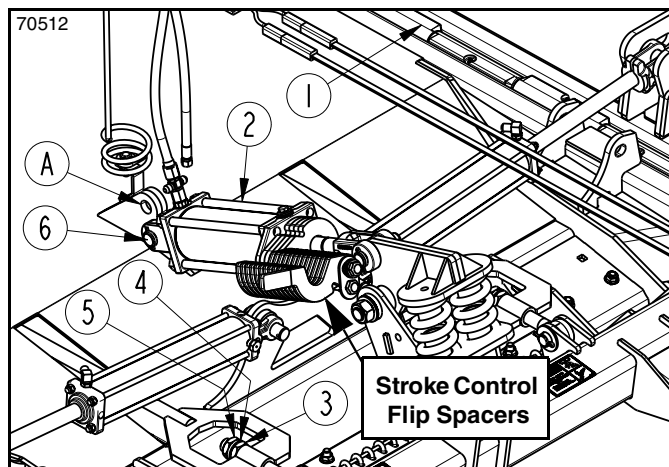

Center Deck Leveling Rods (Lights Removed For Clarity)
Figure 2-3

Level Wing Decks

Refer to **Figure 2-4**:

Each wing section will need adjusting if wing top is not level with center deck top when wings are unfolded.

1. Start tractor and lower wings down. Refer to “**Field Set-up**” on page 36 for instructions on how to lower wings.
2. Pull cutter straight forward six to ten feet to allow outer wing wheels to properly align themselves.
3. Check wing tops with a level to see if they are level with the top of the center deck. If the outer edge of either wing top is higher or lower than the center deck, then that wing should be leveled as follows:
 - a. **If outer wing edge is higher** than the center deck, loosen jam nut (#7) and tighten turnbuckle (#8) to shorten it until lower outer wing edge is level with center deck. Tighten jam nut (#7) to the correct torque when level.
 - b. **If outer wing edge is lower** than the center deck, loosen jam nut (#7) and loosen turnbuckle (#8) to lengthen it until outer wing edge is level with the center deck. Tighten jam nut (#7) to the correct torque when level.

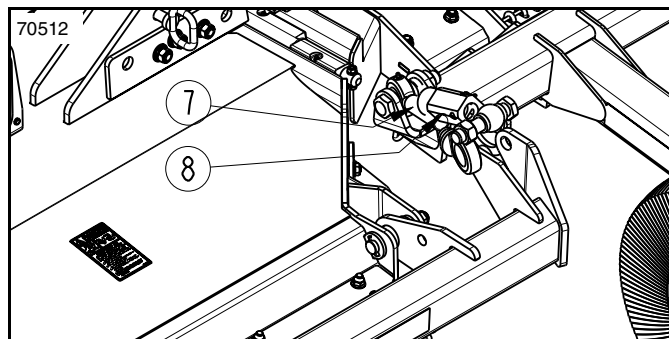

Wing Turnbuckle
Figure 2-4

Section 2: Adjustments

Adjust Cutter Height

NOTE: Make all cutting height adjustments in the field using height of cut grass/material as a guide. Do not measure blade height above ground as the non-operating blade height will be different than the operating blade height.

Refer to Figure 2-5:

1. At the cutting site, unfold wings and raise center deck fully up with lift cylinder.
2. Without relieving hydraulics, shut tractor down properly before dismounting according to “**Tractor Shutdown Procedure**” on page 15.

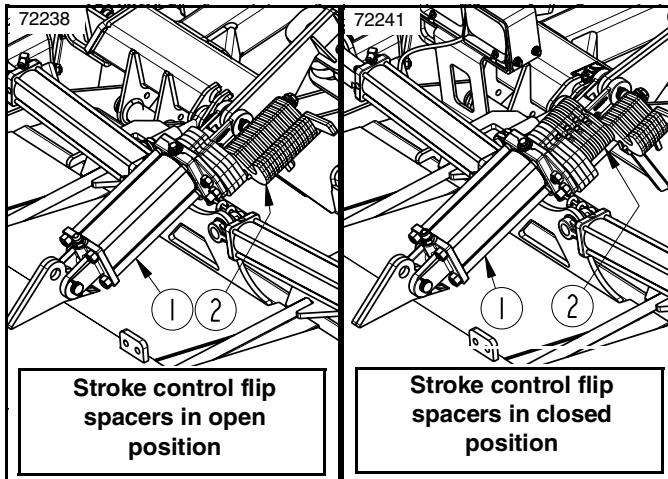

Cutting Height Adjustment
Figure 2-5

WARNING

To prevent serious injury or death:

Stay clear from underneath the cutter and directly behind transport tires. The cutter could fall suddenly causing the decks to lower and tires to roll back.

IMPORTANT: Whether engaging or disengaging stroke control flip spacers, take time to ensure they are in the fully open or fully closed position. Flip spacers not in the fully closed or fully open position can cause damage to the lift cylinder and/or flip spacers.

3. Open all stroke control flip spacers (#2) on lift cylinder (#1).
4. Start tractor and engage blades. See “**Engage Blades**” on page 37 for detailed instructions.
5. Using tractor control lever, adjust cutter to the desired cutting height and then travel forward for approximately 20 to 50 feet (6 m to 15 m).
6. Without relieving hydraulics, shut tractor down properly before dismounting according to “**Tractor Shutdown Procedure**” on page 15.

7. Measure height of cut grass/material. This measurement is the cutting height. If this height is acceptable, continue with step 8. If this height is unacceptable, repeat steps 4-7 until desired cutting height is achieved.
8. Count the required number of stroke control flip spacers to meet desired cutting height.

NOTE: Opening flip spacers lowers cutting height and closing flip spacers raises cutting height.

9. Return to tractor and raise Rotary Cutter up again.
10. Without lowering the cutter, shut tractor down properly before dismounting according to “**Tractor Shutdown Procedure**” on page 15.
11. With tractor shut off and switch key removed, close the amount of stroke control flip spacers determined in step 8.
12. Restart tractor and lower cutter against stroke control flip spacers.
13. Recheck cutting height using steps 4-7. If needed, adjust number of stroke control flip spacers until desired cutting height is achieved.
14. Keep remaining flip spacers in the fully open position.

LP Performance Hitch Hole Size

Refer to Figure 2-6:

The LP Performance hitch is designed to receive 1" diameter hitch pins. To convert the hitch to receive 1 1/4" diameter hitch pins, knock out upper and lower bushings (#1) in clevis (#2).

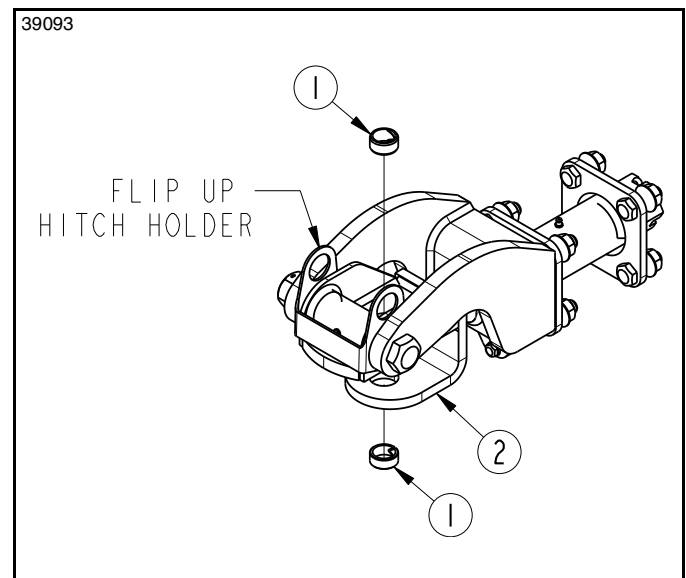

LP Performance Hitch Hole Size
Figure 2-6



Section 3: Operating Instructions

Startup Checklist

Hazard control and accident prevention are dependent upon the awareness, concern, prudence, and proper training involved in the operation, transport, storage, and maintenance of the Rotary Cutter. Therefore, it is absolutely essential that no one operates the rotary cutter unless they have read, fully understood, and are completely familiar with the Operator's Manual. Make sure the operator has paid particular attention to:

- **Important Safety Information**, page 1
- **Section 1: Assembly & Set-up**, page 13
- **Section 2: Adjustments**, page 29
- **Section 3: Operating Instructions**, page 32
- **Section 5: Maintenance & Lubrication**, page 44

Perform the following inspections before using your Rotary Cutter.

Operating Checklist

✓	Check	Page
	Follow installation and hook-up instructions. Refer to "Section 1: Assembly & Set-up".	13
	Make all required adjustments. Refer to "Section 2: Adjustments".	29
	Perform all required maintenance. Refer to "Section 5: Maintenance & Lubrication".	44
	Make sure all guards and shields are in place and in good working condition. Refer to "Gearbox Driveline Shielding" & "Chain Guards".	45 & 53
	Lubricate cutter and drivelines as needed. Refer to "Lubrication Points".	54
	Lubricate all gearboxes and replace oil plugs properly. Refer to "Gearbox and Divider Box Lubrication".	56
	Check cutter initially and periodically for loose bolts and pins. Refer to "Torque Values Chart".	65

Safety Information

DANGER

To avoid serious injury or death:

- Do not walk, stand, or allow anyone else in the area where a raised wing will fall unless the wing is securely locked in the raised position with its transport lock.
- Rotary Cutters have the ability to discharge objects at high speeds; therefore, the use of front & rear safety guards is mandatory with this cutter. Double row chain guards should be used when cutting along roadways and in areas where people may be present. Stop blade rotation if bystanders are in or around the area. It is recommended that a safety shield be placed between the operator and cutter on an open air tractor.
- Tractor power take-off shaft shield, driveline shields, and gearbox shaft shields must be installed and in good working condition to avoid driveline entanglement and projectiles flying off of the driveline.

- Do not use a power take-off adapter. The adapter will increase strain on the tractor's power take-off shaft causing possible damage to shaft and driveline. It will also defeat the purpose of the tractor's power take-off shield.
- Do not engage power take-off while hooking-up or unhooking the driveline, or while someone is standing near the driveline. A person's body and/or clothing can become entangled in the driveline.
- Always disconnect driveline from the tractor before servicing the drivetrain and components powered by the drivetrain. A person can become entangled in the drivetrain if the tractor is started and the power take-off is engaged.
- Always secure equipment with solid, non-concrete supports before working under it. Never go under equipment supported by concrete blocks or hydraulics. Concrete can break, hydraulic lines can burst, and/or hydraulic controls can be actuated even when power to hydraulics is off.
- Keep everyone away from the cutter when folding or unfolding the wings or when raising or lowering the cutter. The cutter can pinch or crush a person when performing these operations.
- Do not raise one or both wings up with power take-off engaged or drivelines rotating. Objects can be thrown by rotating blades. Always keep people away from a cutter that is operating.
- Do not use cutter as a fan. Cutting blades are not properly designed or guarded for this use.
- The cutter must be operated with both wings attached. Removing one wing will increase risk of rollover. Removing one or both wings will expose the blades. Rotating blades will cut body extremities and throw objects.
- Never place hands or feet under the deck or attempt to make adjustments to the cutter with power take-off engaged. Cutter blades rotating at high speeds cannot be seen and are located close to the deck sides. Body extremities will be cut off instantly.

- This cutter is equipped with free-swinging cutting blades to reduce shock loads. However, it is best to avoid striking solid objects for your safety and to protect the cutter from damage.
- Clear area to be cut of debris and other unforeseen removable objects before cutting. Mark non-removable hazards such as tree stumps, post stubs, protruding objects, rocks, drop-offs, holes, etc. with a visible flag.

WARNING

To avoid serious injury or death:

- Allow only persons to operate this implement who have fully read and comprehended this manual, and who have been properly trained in the safe operation of this implement. Serious injury or death can result from the inability to read, understand, and follow instructions provided in this manual.
- Always follow "Tractor Shutdown Procedure" provided in this manual before dismounting the tractor.



Section 3: Operating Instructions

- *Never carry riders on the implement or tractor. Riders can obstruct the operator's view, interfere with controls, be pinched by moving components, become entangled in rotating components, struck by objects, thrown about, fall off and be run over, etc.*
- *Perform scheduled maintenance. Check for loose hardware, missing parts, broken parts, structural cracks, and excessive wear. Make repairs before putting the implement back into service.*
- *Do not operate and/or travel across inclines where the tractor and/or implement can rollover. Consult your tractor's manual for acceptable inclines the tractor is capable of traveling across. When traveling across steep inclines, ensure the wings are folded down.*
- *Do not raise the wing off the ground when traveling across an incline. The weight of the wing will increase the risk of a rollover.*
- *Operate only power machines equipped with a certified Roll-Over Protective Structure (ROPS) and seat belt. Keep folding ROPS in the "locked up" position when appropriate. If ROPS is in the locked up position, fasten seat belt snugly and securely to help protect against serious injury or death from falling and machine overturn.*
- *Watch while making tight turns to ensure that the rear tractor tires and lower 3-point arms do not make contact with cutter hitch, driveline or deck. Keep lower 3-point arms raised at all times when hitched to a pull-type cutter.*
- *Wait for blades to come to a complete stop before accessing blade bolts through blade bolt access hole.*
- *Do not use implement to lift objects; to pull objects such as fence posts, stumps, etc; or to push objects. The unit is not designed or guarded for these uses.*
- *Do not use implement to tow other equipment. Doing so can result in loss of control and damage the equipment.*
- *Do not weld or torch on galvanized metal as it will release toxic fumes.*
- *Do not operate a cutter with a hitch or hitch pin that is excessively worn, bent, broken, or has structural cracks. The hitch and/or hitch pin can break apart separating cutter from tractor.*
- *Some tractors are equipped with two power take-off speeds. Be certain your tractor's power take-off shaft is set-up to operate the implement at its rated power take-off speed. Do not exceed implement's rated power take-off speed. Excessive speed can damage drive components, cutter blades, and/or increase the risk of a thrown object hazard. RC models are rated for 540 rpm and RCM models are rated for 1000 rpm.*
- *Do not operate a broken or bent driveline. Such a driveline will break apart while rotating at high speeds. Always remove the implement from use until the damaged driveline can be repaired or replaced.*
- *Avoid catching hydraulic hoses on brush, posts, tree limbs, and other protrusions that could damage and/or break them.*

- *Buildup of debris around moving components and gearboxes is a fire hazard. Keep rotating parts and gearboxes free from debris.*
- *Improper oil level can cause bearing failure and be a fire hazard. Maintain proper gearbox oil level.*
- *Do not exceed rated cutting capacity of your cutter. See specifications & capacities for specified cutting capacity. Exceeding rated cutting capacity can damage drive components, cutter blades, and deck components.*
- *Cutter blades can continue to rotate while decelerating after power take-off is disengaged. Remain on the tractor seat until rotating parts come to a complete stop.*

IMPORTANT: Maintain correct power take-off speed. Loss of power take-off speed will allow blades to swing back and result in ragged, uneven cutting.

IMPORTANT: Do not let the wings flex down more than 20 degrees while operating the cutter. Doing so can cause damage to the cutter.

IMPORTANT: If wing driveline profile is bent or twisted, disconnect that driveline from the wing gearbox before folding the wing up. This will protect both the wing and divider gearboxes. Repair driveline before putting cutter back into service.

Tractor & Cutter Inspection

Make the following inspections with cutter attached to a tractor and cutter parked on a level surface, power take-off disengaged, and cutter blades stopped.

1. Inspect tractor safety equipment to make sure it is in good working condition.
2. Inspect cutter safety equipment, including all safety chain guards and shielding for proper installation and that they are in good working condition.
3. Check driveline to make certain it is securely connected to the tractor power take-off shaft and cutter gearbox shaft. Also, make certain guards are in good working condition and in place.
4. Check driveline hanger. Make sure it is rotated down away from the driveline.
5. Remove 3-point lower arms or secure them so they do not interfere with driveline, hoses, or hitch.
6. Check all hoses and wires to ensure that they will not pinch or come in contact with the folding wings and rotating drivelines.
7. Start tractor and carefully raise and lower implement to ensure tractor drawbar, tires, and other equipment on the tractor do not contact cutter or power take-off driveline. Also see "**Driveline Clearance Check**" on page 24.
8. Raise center deck fully up. Without lowering implement, shut tractor down properly before dismounting according to "**Tractor Shutdown Procedure**" on page 15.

Section 3: Operating Instructions

9. Place solid, non-concrete support blocks or jack stands under the four center deck corners.
10. Start tractor and lower center deck down onto supports.
11. Shut tractor down properly before dismounting.
12. With cutter resting on solid, non-concrete supports, power take-off disengaged, and blade rotation completely stopped:
 - Check for and remove foreign objects wrapped around blade spindles.
 - Check for nicked, bent, broken, and worn cutting blades. Replace or sharpen blades as required. Refer to “**Cutter Blades**” on page 47.
13. Inspect hydraulic hoses for wear, damage, and hydraulic leaks. Before checking for leaks, read “**Avoid High Pressure Fluids Hazard**” on page 3. Replace damaged and worn hoses with genuine Land Pride parts.
14. Make repairs to cutter and tractor before continuing with “**Blade Operation Inspection**” on this page.

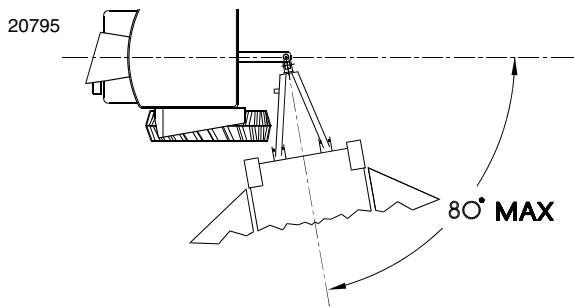

Constant Velocity (CV) Driveline
Figure 3-1

Avoid Extreme Turning Angles

Refer to Figure 3-1:

Plan your field cutting to minimize number of turns, especially extreme turning angles. Avoid tractor-to-cutter turning angles that exceed driveline maximum turning angle. If the turn cannot be avoided, disengage tractor power take-off and wait for driveline to stop before making the turn.

- **Constant Velocity Driveline:**
Maximum turning angle = 80°.

Blade Operation Inspection

DANGER

To prevent serious injury or death:

Tractor power take-off shaft shield, driveline shields, and gearbox shaft shields must be installed and in good working condition to avoid driveline entanglement and projectiles flying off of the driveline.

WARNING

To avoid serious injury or death:

- Always follow “Tractor Shutdown Procedure” provided in this manual before dismounting the tractor.
- Stop power take-off immediately if vibration continues after a few revolutions during start-up and anytime vibration occurs thereafter.
- Some tractors are equipped with two power take-off speeds. Be certain your tractor’s power take-off shaft is set-up to operate the implement at its rated power take-off speed. Do not exceed implement’s rated power take-off speed. Excessive speed can damage drive components, cutter blades, and/or increase the risk of a thrown object hazard. RC models are rated for 540 rpm and RCM models are rated for 1000 rpm.

IMPORTANT: Read all “**Safety Information**” starting on page 32 before operating the cutter.

1. Make sure cutter blades are not locked against each other. See “**Field Set-up**” on page 36.
2. Remove deck supports and set transport locks for field operations. See “**Transport Pins**” on page 34.
3. Lower cutter decks until blades are about 2" (5 cm) off the ground.
4. Start tractor and set throttle speed just above idle. If available, use tractor’s power take-off soft start option. Slowly engage power take-off to get blades rotating. (See “**Engage Blades**” instructions on page 37.)
5. Initial start-up vibration is normal and should stop after a few revolutions. Stop power take-off rotation immediately if vibration continues.
6. Once cutter is running smoothly, increase throttle to full cutter speed (540 or 1000 rpm). If cutter vibrates excessively for 3 seconds at full speed, immediately disengage power take-off, and shut tractor down properly before dismounting according to “**Tractor Shutdown Procedure**” on page 15.
7. Block center deck up before working under cutter.
8. Check blades for a locked-up situation. Unlock blades if locked-up.
9. Check for other probable causes such as broken or bent blades, loose blades, loose gearbox mounting bolts, bent driveline etc.
10. Take proper precautions to make necessary repairs and adjustments.
11. Repeat steps 1-10 above to make certain vibration is corrected before putting cutter back into service.

Transport Pins

IMPORTANT: Always disengage tractor’s power take-off and wait for blades to come to a complete stop before raising the wings to transport position. Wing drivelines, wing gearboxes, and splitter gearbox can be damaged if driveline is turning.

Section 3: Operating Instructions

NOTE: The wings are controlled with two hydraulic lift cylinders. Be certain that the wing hydraulics are attached to the tractor and the hydraulic hoses are purged of air before proceeding.

Cutter wings will need to be raised before transporting on a roadway, through narrow gate openings and when servicing the deck underside.

1. Disengage power take-off and wait for cutter blades to come to a complete stop before raising wings.
2. Raise cutter wings fully up with hydraulics.
3. Without relieving hydraulic pressure, shut tractor down properly before dismounting according to “**Tractor Shutdown Procedure**” on page 15.

DANGER

To prevent serious injury or death: Do not walk, stand, or allow anyone else in the area where a raised wing will fall unless the wing is securely locked in the raised position with its transport lock.

4. **See Figure 3-2:** Remove hairpin cotter (#1) from transport pin (#2) and remove the transport pin (#2) from storage holes (#4).
5. **See Figure 3-3:** Insert transport pin (#2) through lock hole (#3) and secure it with hairpin cotter (#1).
6. Repeat steps 4 and 5 for the other wing. Your cutter is now ready for transporting.

Transporting

WARNING

To avoid serious injury or death:

- Always raise wings and set transport locks before transporting from one work site to another and before traveling on public roadways. The wings can fall if not secured with transport locks.
- Always travel with cutter at a safe transport height. Be sure that it is high enough to clear ground obstacles but not too high that the cutter is unstable on hill sides or tight turns.
- Select a safe ground speed that will allow adequate control of steering and stopping. Never exceed 20 mph (32.2 km/h) with attached equipment. Rough terrain requires a slower speed.
- Watch while making tight turns to ensure that the rear tractor tires and lower 3-point arms do not make contact with cutter hitch, driveline or deck. Keep lower 3-point arms raised at all times when hitched to a pull-type cutter.
- When traveling on public roads, use LED lights, slow moving vehicle sign, clean reflectors, and other adequate devices to warn operators in other vehicles of your presence. If implement blocks visibility of slow moving vehicle sign, relocate sign so it is visible from the back at all times. Always comply with all federal, state, and local laws.
- When transporting after dark, use the power machine’s working lights to avoid hitting objects and being hit by approaching vehicles.

IMPORTANT: The SMV sign should not be used when transporting equipment on a truck or trailer exceeding speeds of 25 mph (40km/h). Cover or remove the SMV sign when hauling the cutter.

1. Always fold the wing up and set the transport lock before traveling on public roadways.
2. With the center deck fully up, shut tractor down according to “**Tractor Shutdown Procedure**” on page 15. Close all flip spacers with the red handle.
3. Retract lift cylinder until the cylinder rod clevis comes against the flip spacers.
4. Relocate slow moving vehicle sign (SMV) from the back of the tractor to the SMV mount on the back of the center axle. If needed, a SMV sign can be purchased from your nearest Land Pride dealer. Refer to “**Slow Moving Vehicle Sign Accessory**” on page 41.
5. Be sure to reduce tractor ground speed when turning and leave enough clearance so the cutter does not contact obstacles such as buildings, trees, or fences.
6. Always raise wings and set transport pins before traveling on public roadways.
7. When traveling on roadways, transport in such a way that faster moving vehicles may pass you safely.
8. Operate tractor at a lower speed when traveling over rough or hill-like terrain.

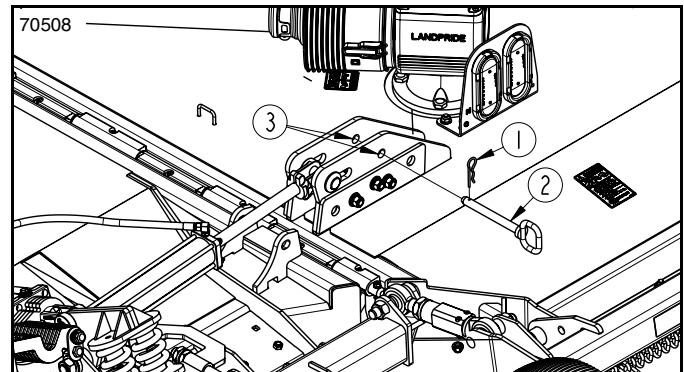

Transport Pin, Storage Position
Figure 3-2

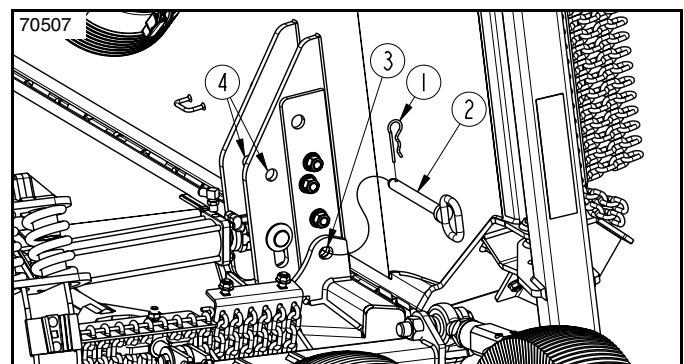

Transport Pin, Locked Position
Figure 3-3

Section 3: Operating Instructions

Field Set-up

DANGER

To prevent serious injury or death:

Clear area to be cut of debris and other unforeseen removable objects before cutting. Mark non-removable hazards such as tree stumps, post stubs, protruding objects, rocks, drop-offs, holes, etc. with a visible flag.

WARNING

To prevent serious injury or death:

The following operational procedures should be carried out by the tractor operator. Other persons should not be in the area. All cutter operations including field set-up should be stopped when other persons are in the vicinity.

IMPORTANT: Cutting should not be done in wet conditions. Wet material will build up on the deck underside creating high wear, poor discharge, and the need for additional horsepower.

Field Inspections

Thoroughly inspect area to be cut for debris and unforeseen objects. Remove all potential hazards and mark any that cannot be removed.

Unfold Wings and Set Deck Cutting Height

DANGER

To prevent serious injury or death:

Keep everyone away from the cutter when folding or unfolding the wings or when raising or lowering the cutter. The cutter can pinch or crush a person when performing these operations.

Refer to Figure 3-4:

IMPORTANT: Cutting blades may become locked together (overlapped) when the wings are raised for transport. Operating cutter in this condition will result in severe deck vibration. Inspect wings for locked blades prior to power-on operation.

1. Inspect blade carriers for locked blades prior to lowering the wings. Separate locked blades.
2. Start tractor and raise both wings up to release any tension on the transport lock pins.
3. Without lowering the cutter, shut tractor down before dismounting according to “**Tractor Shutdown Procedure**” on page 15.

Refer to Figure 3-3 on page 35:

4. Remove hairpin cotters (#1) from both left and right side transport pins (#2).

Refer to Figure 3-2 on page 35:

5. Store transport pins (#2) in storage holes (#4) and secure them with hairpin cotters (#1).
6. Start tractor and lower both wings down.

7. Adjust cutter to field cutting height. See “**Adjust Cutter Height**” on page 31 for detailed instructions.

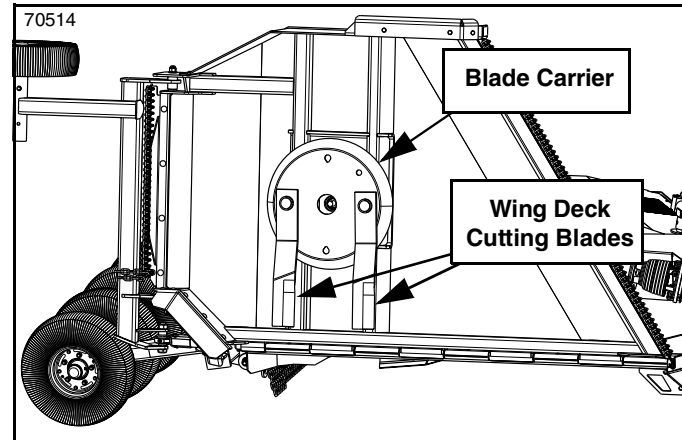

Wing Deck Blade Position
Figure 3-4

Set Wing Lift Lever to Float Position

IMPORTANT: The wing folding levers should be in float position to avoid damage to the wing hydraulic cylinders and axles while cutting on uneven terrain.

IMPORTANT: Do not let the wings flex down more than 20 degrees while operating the cutter. Doing so can cause damage to the cutter.

Use float position of your tractor’s hydraulic system to provide automatic floating of wings for varying terrain conditions. This will ensure wing gauge wheels are in continuous contact with the ground at all times.

Select Gear Range

Optimum ground speed depends on density of material being cut, horsepower rating of tractor, and (in some cases) terrain. Always operate tractor at cutter’s full-rated power take-off speed in a gear range that allows the cutter to make a smooth cut without lugging the tractor down, usually between 2 to 5 mph (3.2 to 8.0 km/h). Loss of power take-off speed will allow blades to hinge back and result in ragged, uneven cutting.

NOTE: Never run tractor in an economy mode or any other mode that will drop power or speed from the power take-off. This may result in ragged and uneven cutting.

Section 3: Operating Instructions

Engage Blades

IMPORTANT: Cutter blades can lock-up against each other during start-up and shut-down, especially if tractor's power take-off engagement is "INSTANT ON" and/or "INSTANT OFF". Follow Blade Engagement and Blade Disengagement instructions to help eliminate blade lock up.

1. Select a gear range that will allow the cutter to make a smooth cut without lugging the tractor down. See "**Select Gear Range**" on page 36.
2. With wings lowered, increase throttle to a speed just enough to get the cutter started without stalling tractor, while slowly engaging power take-off. Use tractor's power take-off soft start option if available.
3. Ensure power shafts are rotating and cutter is not vibrating excessively after ramping up to full power take-off speed for at least 3 seconds. If excessive vibration continues after 3 seconds at full power take-off speed, disengage power take-off immediately, shut tractor down, and remove switch key. Wait for blades to stop rotating before dismounting tractor.
4. Investigate cause if cutter was shut down due to excessive vibration. See "**Blade Carrier Blockage Removal During Field Use**" on this page for detailed instructions.
5. If cutter was not shut down, continue with forward cutting operation at full power take-off operating speed. Make a new gear selection if tractor is lugging down or if cutter is making a rough cut.
6. Periodically, shut tractor down according to "**Tractor Shutdown Procedure**" on page 15 and inspect cutter.
7. Dismount tractor and check for objects wrapped around blade spindles. Block deck up before removing objects.
8. Frequently inspect cutter for loose bolts and nuts. Tighten all loose hardware as indicated in the "**Torque Values Chart**" on page 65.

Disengage Blades

1. Slowly decrease throttle speed until engine idle speed is reached.
2. Disengage power take-off.
3. Shut tractor down according to "**Tractor Shutdown Procedure**" on page 15.

IMPORTANT: It will take longer for the blades to come to a complete stop on cutters equipped with a main driveline that has an overrunning clutch, as opposed to a cutter with a main driveline that does not have an overrunning clutch.

Blade Carrier Blockage Removal During Field Use

DANGER

To avoid serious injury or death:

- Do not walk, stand, or allow anyone else in the area where a raised wing will fall unless the wing is securely locked in the raised position with its transport lock.
- Never place hands or feet under the deck or attempt to make adjustments to the cutter with power take-off engaged. Cutter blades rotating at high speeds cannot be seen and are located close to the deck sides. Body extremities will be cut off instantly.
- Keep everyone away from the cutter when folding or unfolding the wings or when raising or lowering the cutter. The cutter can pinch or crush a person when performing these operations.

WARNING

To avoid serious injury or death:

- Cutter blades can continue to rotate while decelerating after power take-off is disengaged. Remain on the tractor seat until rotating parts come to a complete stop.
 - Always follow "Tractor Shutdown Procedure" provided in this manual before dismounting the tractor.
 - Do not attempt to remove blockages from blade carriers while the wings are in the folded-up position. Blades can become locked by blockages, creating the potential for blades to swing freely in a harmful manner while removing the blockages, bringing about the potential for serious injury.
1. Ensure cutter is securely attached to tractor, then park tractor and cutter on a level surface.
 2. Disengage power take-off and wait for cutter blades to come to a complete stop.
 3. Raise cutter fully up with hydraulics.
 4. Without relieving hydraulics, shut tractor down according to "**Tractor Shutdown Procedure**" on page 15.
 5. Position all stroke control flip spacers to the fully closed position, demonstrated in **Figure 2-5** on page 31.
 6. Start tractor and lower cutter to rest on spacers.
 7. Properly shut tractor down before dismounting. Make sure to relieve all hydraulic pressure on lift and wing cylinders.
 8. While exercising caution, carefully proceed to cut and remove any blockages.
 9. Discard removed blockages appropriately so they do not pose a hazard to the cutter once cutting resumes.



Section 3: Operating Instructions

General Operating Instructions

It is important that you familiarize yourself with the Operator's Manual, complete the Operator's Checklist, properly attach the cutter to your tractor, make leveling adjustments, preset cutting height, and set wing folding hydraulic control lever to the float position before beginning a running operational safety check on your Land Pride RC4715 or RC(M)4715 Rotary Cutter.

It's now time to do a running operational safety check. It is important that at any time during this safety check you detect a malfunction in either the cutter or tractor that you immediately shut the tractor off, remove the key, and make necessary repairs and/or adjustments before continuing on.

Before starting the tractor, make sure the park brake is engaged and power take-off is disengaged. If wings are folded up, follow instructions in this manual to unfold wings. Start the tractor and set engine throttle speed at a low idle. Raise cutter with tractor's rear hydraulic lift control lever to transport position, making sure that the power take-off shaft does not bind and does not contact the cutter frame. Lower cutter to the ground and at a low engine speed, engage power take-off. If everything is running smoothly at a low idle, slowly raise the cutter to transport height, while checking for bind or chatter in the driveline. Lower cutter to the ground and increase tractor's engine rpm until it reaches the cutter's full power take-off operating speed which will be either 540 or 1000 rpm depending on your model. If everything is still running smoothly, once more raise the cutter to transport height to check for driveline bind or chatter. Lower cutter to the ground, return engine to a low idle, and disengage the power take-off. Be sure tractor 3-point arms are raised and will not contact main driveline.

You should now be ready to transport to your cutting site at a safe ground speed. On roadways, transport in such a manner that faster moving vehicles can easily see you and pass you safely. Reduce your speed when traveling over rough and hill-like terrain. Avoid quick or sharp steering corrections. Take extra care to ensure that the cutter doesn't come into contact with obstacles such as trees, buildings, or fences. Use accessory lights and appropriate reflective devices to provide adequate warning to pedestrians and other vehicle operators when traveling on public roads and in the dark of night. Comply with all local, state and federal laws.

It is important that you inspect the area where you will be cutting and clear it of safety hazards and foreign objects either before or after you arrive at the cutting site. Never assume the area is clear. Cut only in areas which you are familiar with and are free of foreign objects. Extremely tall grass should be cut twice to detect potential hazards. In the event you do strike an object, stop the cutter and tractor immediately to inspect and make necessary repairs to the cutter before resuming operation. It really pays to inspect a new area and to develop a safe plan before cutting.

Depending on your specific model, you will need to maintain either 540 or 1000 rpm power take-off speed and 2 to 5 mph (3.2 to 8.0 km/h) ground speed to produce a clean cut. Make a tractor gear and range selection that will enable you to maintain these speed combinations. Generally, the quality of cut is better at lower ground speeds. Dense ground cover will create the need to slow down even more. In certain conditions, tractor tires will roll grass down resulting in an uneven cut when the grass fails to rebound. Should this happen, you may try reversing the direction of cut and/or double cut to achieve the desired finish. Avoid very low cutting heights, especially on extremely uneven terrain. Always cut downward on slopes and avoid crossing the face of steep slopes. Avoid sharp drops and cross diagonally through dips to prevent hanging up the tractor and cutter. Slow down in turns and avoid sharp turns if at all possible.

Now that you're prepared and well briefed, you may begin cutting. Begin cutting by doing the following:

- Reduce tractor's engine rpm.
- Make sure the wheels supporting the wings are on the ground and the hydraulic control lever for folding the wings is set in the float position.
- Engage power take-off, raise engine rpm to the appropriate power take-off speed, and begin cutting.

Try increasing or decreasing ground speed to determine the effect on quality of cut. With a little practice you will be pleased with what your Land Pride 15' Folding Rotary Cutter can do.

When you are done cutting, need to take a break, or just need to make a few adjustments to the cutter, remember to always do the following:

- Reduce tractor's engine rpm and disengage power take-off.
- Stop on level ground, place gear selector in park or set park brake, turn off engine, remove switch key, and stay on the tractor until cutter blades have come to a complete stop.



Section 4: Options & Accessories

Safety Chain Guards



To prevent serious injury or death:

Rotary Cutters have the ability to discharge objects at high speeds; therefore, the use of front & rear safety guards is mandatory with this cutter. Double row chain guards should be used when cutting along roadways and in areas where people may be present. Stop blade rotation if bystanders are in or around the area. It is recommended that a safety shield be placed between the operator and cutter on an open air tractor.

Land Pride offers two types of safety guards to best suit your application: single row chain guards and double row chain guards.

- Single row chain guards are constructed with a single row of hanging chain links.
- Double row chain guards are constructed with two rows of hanging chain links. The extra chain provides an additional barrier for stopping thrown objects.

- 331-992A Single Row Chain Guards
- 331-993A Double Row Chain Guards

Hitches

Land Pride offers 5 different hitches to best suit your application. See “**Hitch Types**” on page 14 for complete description of optional hitches.

- 334-744A Swivel Clevis Hitch
- 334-460A Bar-Tite Hitch
- 334-462A Ball Hitch
- 334-470A Pintle Hitch
- 334-471A LP Performance Hitch

Deck Protection Options

- **No protection:** The decks are standard construction without additional protection added to their underside such as the Deck Ring or Deck Armor™.
- **Deck Ring:** Land Pride offers a deck ring option for extra protection for the deck sheet and structure. The deck rings are welded to the underside of the center deck and wing decks to protect from bent and deflected blades caused by hitting obstructions.

Wing Fold Options

Land Pride offers four wing folding options to best suit your application. The dual-acting cylinders have a narrower transport width than single-acting cylinders.

- **Single-acting:** Simultaneously raise and lower wings with single-acting cylinders. Relies on gravity to pull wings to ground. Uses 1 hydraulic duplex.
- **Dual-acting:** Simultaneously raise and lower wings with dual-acting cylinders. Hydraulically power wings up and down. Uses 1 hydraulic duplex.
- **Independent single-acting:** Independently raise and lower each wing with single acting cylinders. Uses 2 hydraulic duplexes.
- **Independent dual-acting:** Independently raise and lower each wing with dual-acting cylinders. Uses 2 hydraulic duplexes.

Tire Options & Configurations

Land Pride offers five different tire options to choose from, with each option available in a 6 or 8 tire configuration.

- **Laminated Tires:** Available sizes are 21" and 26" tires. They are constructed of laminated layers of solid rubber that will never go flat.
- **New Tires:** 25.5", 20 ply tires are available as foam and air-filled. Both are built tough to withstand the rugged use a cutter receives, as well as providing a smoother ride when transporting. Foam-filled tires will not go flat.
- **Used Aircraft Tires:** Available as a 29" pneumatic tire or 24" foam-filled tire. They are built tough to withstand the rugged use a cutter receives and to provide a smoother ride when transporting.
- **6 Tire Configuration:** Four tires on transport axle and one on each wing axle.
- **8 Tire Configuration:** Four tires on transport axle and two on each wing axle.

Section 4: Options & Accessories

Axle Options and Configurations

Land Pride offers a multitude of axle options to ensure your Rotary Cutter is properly fitted for its intended application. Purchaser must choose one center axle option and one wing option.

Single Suspension Center and Wings

Refer to Figure 4-1:

This center and wing axle option provides suspension through the use of two springs located directly behind the center deck's lift cylinder. It is best suited for relatively flat and even terrain.

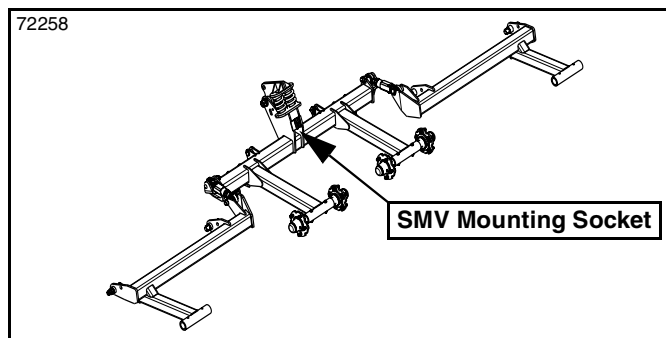

Figure 4-1

Center Axle Options

HD Single Suspension Center Axle

Refer to Figure 4-2:

This heavy duty (HD) center axle option provides suspension through the use of two springs located directly behind the center deck's lift cylinder. The HD axles features bigger tubing and large gussets, making it a great option when the cutters main application goes just beyond flat and even terrain. This option allows the purchaser to choose a separate wing axle option that meets their needs.

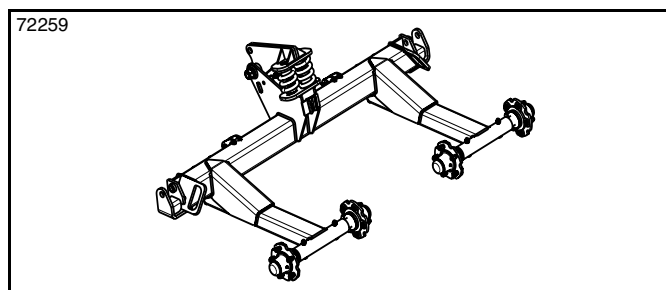

Figure 4-2

Independent Suspension Center Axle

Refer to Figure 4-3:

Not applicable with "HD Solid Wing Axles" on page 41.

This HD center axle option provides independent suspension. Each trailing arm features a rocker and spring to better handle rough terrain. When field terrains are less than ideal, and additional suspension support is needed, this center axle option will easily meet those expectations.

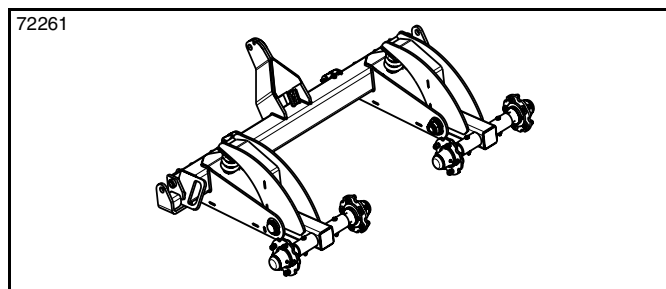

Figure 4-3

Walking Tandem Center Axle

Refer to Figure 4-4:

The walking tandem axle features a beam on each trailing arm that pivots front to back. The beam pivots in the center with a spindle in front and a spindle in back of the pivot. This axle is great for walking through washouts or on/off curbs.

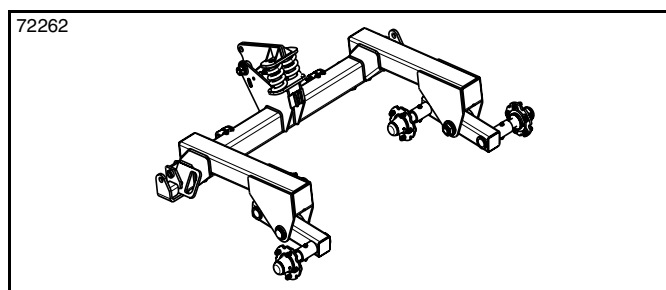

Figure 4-4

Pivot Parallel Center Axle

Refer to Figure 4-5:

The parallel pivot axle features a beam on each trailing arm that pivots side to side. The side to side pivoting action spreads the weight evenly between the wheel. This axle is great for holding slopes while minimizing tire wear.

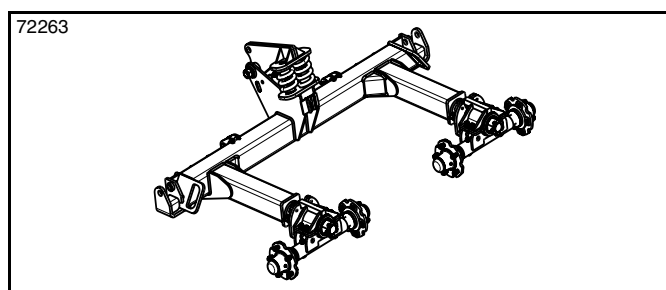

Figure 4-5

Section 4: Options & Accessories

Wing Axle Options

HD Solid Wing Axles

Refer to Figure 4-6:

Not applicable with “Independent Suspension Center Axle” on page 40.

This HD wing axle option is provided with suspension support through the springs incorporated into all compatible center axle options. Each wing axle is solidly built with bigger tubing supported by a large gusset, allowing the cutter to successfully take on a vast array of field terrains.

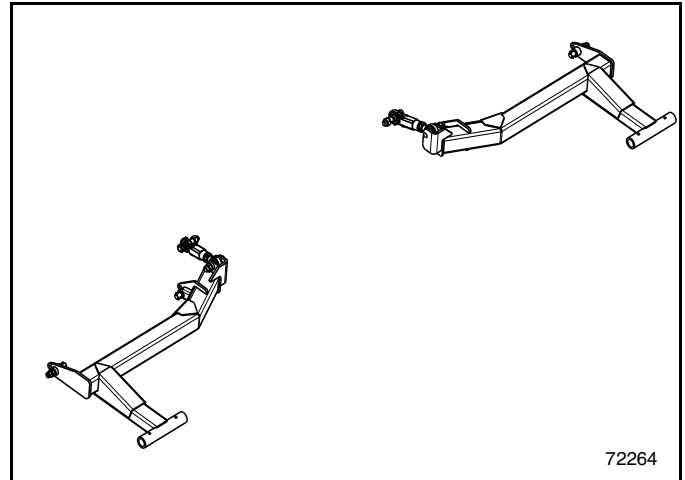

Figure 4-6

Independent Suspension Wing Axles

Refer to Figure 4-7:

This HD wing axle option provides independent suspension to both wings. Each wing attains support through the wing axle’s trailing arm, which features a rocker and spring to better handle rough terrain. When field terrains are challenging, this wing axle option ensures your implement is provided with ample suspension support across the full width span of the cutter.

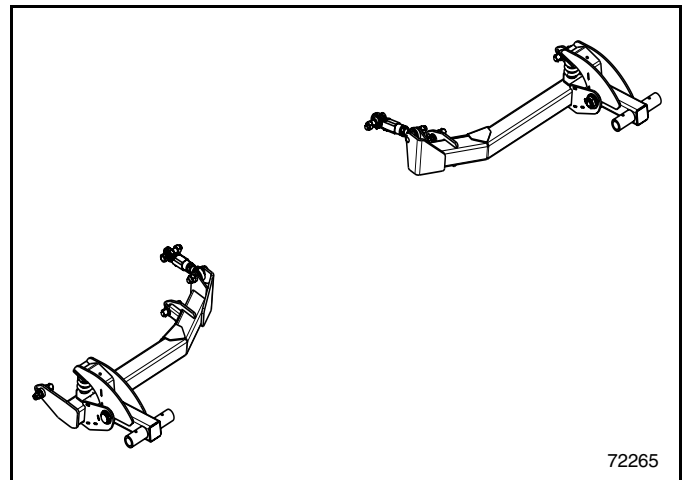

Figure 4-7

Slow Moving Vehicle Sign Accessory

Refer to Figure 4-8:

Land Pride offers as an accessory, the slow moving vehicle sign with mounting blade (#1) for tractors not equipped with a removable sign or when the tractor’s sign does not fit Land Pride’s mounting socket (#4). See Figure 4-1 for location of SMV mounting socket.

If you have need for mounting this sign on other equipment, mounting hardware (#2, #3, & #4) can be purchased from your nearest Land Pride dealer.

Item	Part No.	Description
1	316-362S	SLOW MOVING VEHICLE SIGN
2	802-092C	RHSNB 5/16-18X3/4 GR5
3	803-177C	NUT HEX FLG TP LK 5/16-18ZNYCR
4	890-401C	MOUNTING SOCKET

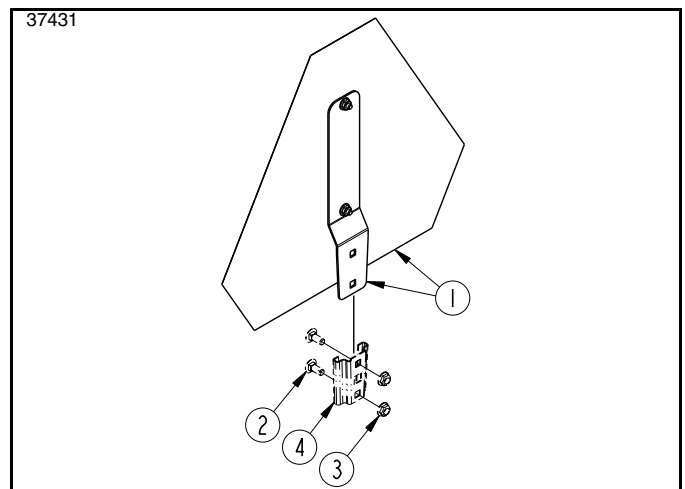

Figure 4-8



Section 4: Options & Accessories

Main Drivelines

Land Pride offers two different CAT 6 main drivelines to best suit your application.

- CAT 6 constant velocity drivelines allow the operator to make up to 80 degree turns.
- CAT 6 constant velocity drivelines with overrunning clutch have the same features as the CAT 6 constant velocity driveline plus the overrunning clutch feature. The overrunning clutch helps protect the tractor's power take-off shaft, especially if the tractor has instant power take-off breaking.

CAT 6 Constant Velocity

- 826-643C CAT 6 CV driveline 1 3/8", 540 rpm
- 826-644C CAT 6 CV driveline 1 3/8", 1000 rpm
- 826-645C CAT 6 CV driveline 1 3/4", 1000 rpm

CAT 6 Constant Velocity With Overrunning Clutch

- 826-884C CAT 6 CV driveline 1 3/8", 540 rpm
- 826-793C CAT 6 CV driveline 1 3/8", 1000 rpm

Blade Carrier Options

Land Pride offers the following blade carrier options to choose from when outfitting your Rotary Cutter. Blade rotation for the options are:

- Left-hand deck Clockwise blade rotation
- Center deck Counterclockwise blade rotation
- Right-hand deck Counterclockwise blade rotation

- **Forged Blade Bar:**

This blade carrier option provides critical strength to the blade mount for consistent, top level performance.

- **Bolt-on Dishpan:**

This option includes the forged blade bar with a bolt-on dishpan. It combines the strength and performance of the Forged Blade Bar and protection to the gearbox and blade spindle.

- **Welded Dishpan:**

This option includes 1" thick blade bars welded to the dishpan in a cross pattern. It combines the strength and performance of the plate blade Bar and protection to the gearbox and blade spindle.

- **Shredder Kit Option:**

This option includes a double stacked shredder blade configuration on each blade spindle. It is ideal for cutting residue into smaller pieces.

Blade Accessories

Land Pride offers three different cutting blade options. They include High Lift blades, standard blades, and Low Lift blades. For the removal and installation of cutting blades, refer to section "Cutter Blades" on page 47.

NOTE: The "CCW" notation refers to counter clockwise rotation, where as the "CW" notation refers to clockwise rotation. Rotation direction is determined by looking down at the deck.

- **High Lift blades:** These blades are great for achieving grass-cut quality, and cutting at taller cut heights. However, they are not ideal for trees and heavy brush.

- 820-724C Wing CCW rotation
- 820-725C Center CCW rotation
- 820-726C Wing CW rotation
- 820-727C Center CW rotation (not standard)

- **Standard blades:** These blades offer a good combination of grass-cut quality and the ability to handle trees and heavy brush.

- 820-720C Wing CCW rotation
- 820-721C Center CCW rotation
- 820-722C Wing CW rotation
- 820-723C Center CW rotation (not standard)

- **Low Lift blades:** These blades are great for stemmed material, trees, and heavy brush. They are also known to stand up well in conditions that contain gopher mounds and ant hills. They are not as suitable as High Lift and standard blades when looking to achieve grass-cut quality.

- 820-478C Center CCW rotation
- 820-479C Wing CCW rotation
- 820-480C Wing CW rotation
- 820-544C Center CW rotation (not standard)

Section 4: Options & Accessories

Single Duplex Accessory

Land Pride offers the single duplex accessory kit to change the cutter from requiring two tractor duplex outlets to only requiring one duplex outlet.

Single Duplex Fittings Bundle

334-754A Single duplex accessory

Refer to Figure 4-9:

1. Remove hydraulic hose (#1) from hydraulic tee fitting (#2) and set to the side.
2. Remove hydraulic hose (#3) from hydraulic tee fitting (#2) and set to the side.
3. Hydraulic tee fitting (#2) and hydraulic hose (#4) are no longer needed.
4. Remove hydraulic hose (#5) from hydraulic adapter fitting (#6).
5. Remove hydraulic adapter fitting (#6) from the lift cylinder's port hole (#7) and put away as it is no longer needed.
6. Install hydraulic adapter fitting (#8) to the lift cylinder's port hole (#7). Tighten fitting.
7. Install hydraulic cross fitting (#9) to hydraulic adapter fitting (#8). Tighten fitting.
8. Install hydraulic adapter fitting (#10) to hydraulic cross fitting (#9). Tighten fitting.
9. Install hydraulic hose (#1) to hydraulic cross fitting (#9) as shown. Tighten hose.
10. Install hydraulic hose (#3) to hydraulic cross fitting (#9) as shown. Tighten hose.
11. Install hydraulic hose (#5) to hydraulic adapter fitting (#10) as shown. Tighten hose.
12. Make sure all hoses and fittings are tightened.

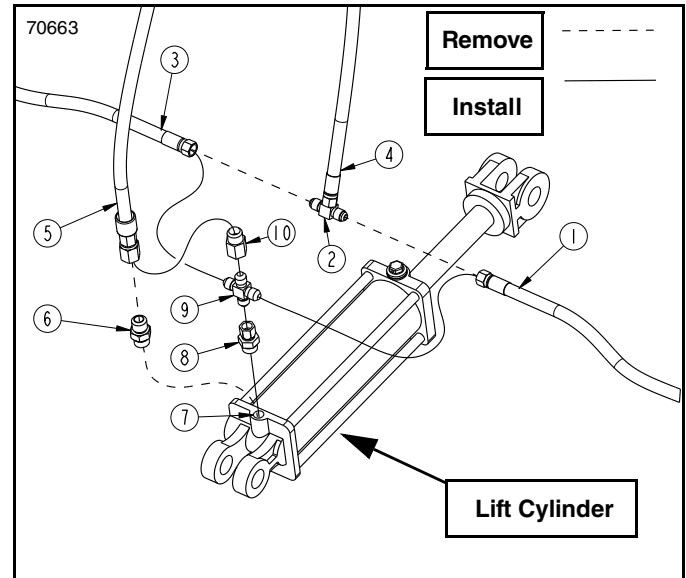

Single Duplex Hook-up
Figure 4-9

Dual-Acting Lift Cylinder Accessory

Land Pride offers the Dual-Acting Lift Cylinder accessory, which allows the operator to lower the deck with hydraulic power instead of gravity. The air vent in the lift cylinder is replaced with a hydraulic fitting and hose. It is ideal for dirty and corrosive environments, aiding in the prevention of contaminants getting into the lift cylinder.

Dual-Acting Lift Cylinder Kit

334-927A Dual-acting lift cylinder accessory

Refer to Figure 4-10:

1. Remove vented plug (#1) from lift cylinder port hole. Store plug away as it is no longer needed.
2. If attached, remove threaded end of hydraulic hose (#3) from hydraulic fitting (#2).
3. Thread hydraulic fitting (#2) into lift cylinder port hole as shown and tighten down. Be sure to orient connecting end of hydraulic fitting (#2) toward the front of cutter. Doing so will eliminate the potential of a pinched hydraulic hose when cutter is in use.

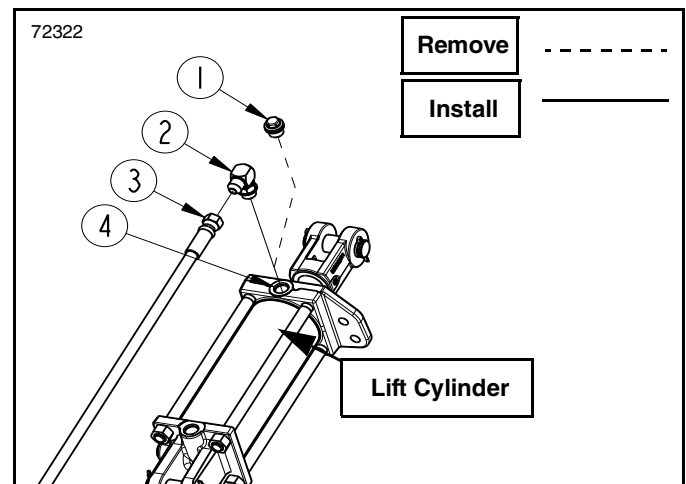

Dual-Acting Lift Cylinder Accessory Hook-up
Figure 4-10

4. With hydraulic fitting properly oriented, attach hydraulic hose (#3) by tightening threaded end of hose onto hydraulic fitting (#2). Be sure to hold hydraulic fitting (#2) with a wrench when tightening hydraulic hose (#3) onto fitting to eliminate stress.

Section 5: Maintenance & Lubrication

General Maintenance

Proper servicing and adjustments are key to the long life of any implement. With careful inspection and routine maintenance, you can avoid costly downtime and repair.

Check all bolts and pins after using the cutter for several hours and on a regular basis thereafter to ensure they are tight and secured. Replace worn, damaged, or illegible safety labels by obtaining new labels from your Land Pride dealer.

Periodically, shutdown tractor by following the “**Tractor Shutdown Procedure**” on page 15. Dismount tractor and check for objects wrapped around blade spindles. Block deck up with solid, non-concrete supports before removing objects.

DANGER

To prevent serious injury or death:

- Always secure equipment with solid, non-concrete supports before working under it. Never go under equipment supported by concrete blocks or hydraulics. Concrete can break, hydraulic lines can burst, and/or hydraulic controls can be actuated even when power to hydraulics is off.
- Always disengage power take-off, shut tractor down, and wait for cutter blades to spool down to a stop before allowing anyone to clean, service, preform maintenance, or be near the cutter. Refer to tractor shutdown procedures provided in this manual.

WARNING

To avoid serious injury or death:

- Always follow “Tractor Shutdown Procedure” provided in this manual before dismounting the tractor.
- Make sure controls are all in neutral position or park before starting the power machine.
- Perform scheduled maintenance. Check for loose hardware, missing parts, broken parts, structural cracks, and excessive wear. Make repairs before putting the implement back into service.
- Do not alter implement or replace parts on the implement with other brands. Other brands may not fit properly or meet OEM (Original Equipment Manufacturer) specifications. They can weaken the integrity and impair the safety, function, performance, and life of the implement. Replace parts only with genuine OEM parts.
- Buildup of debris around moving components and gearboxes is a fire hazard. Keep rotating parts and gearboxes free from debris.
- Improper oil level can cause bearing failure and be a fire hazard. Maintain proper gearbox oil level.

Hydraulic System

One of the most important things you can do to prevent hydraulic system problems is to ensure your tractor's hydraulic reservoir remains free of dirt and other contaminations.

Use a clean cloth to wipe hose ends clean before attaching them to your tractor. Replace tractor hydraulic filter element at the prescribed intervals. Such maintenance will go a long way to prevent the occurrence of control valve and hydraulic cylinder problems.

Check for signs of damaged or worn hydraulic hoses, fittings and cylinders before each use of the cutter. Replace damaged components as needed. Order only genuine Land Pride parts from your local Land Pride dealer.

WARNING

To avoid serious injury or death:

Hydraulic fluid under high pressure will penetrate the skin or eyes causing a serious injury. Wear protective gloves and safety glasses or goggles when working with hydraulic systems. Use a piece of cardboard or wood rather than hands when searching for leaks. If an accident occurs, seek immediate emergency medical care or gangrene may result. **DO NOT DELAY.**

Tires

WARNING

To avoid serious injury or death:

- Tire changing can be dangerous and should be performed by trained personnel using correct tools and equipment. When removing and installing wheels, use wheel handling equipment adequate for the weight involved.
- Always release all air pressure in air-filled airplane tires before removing hardware bolting the split rims together. Not doing so can cause the split rims to blow apart instantly and could result in serious injury or death.
- When inflating tires, use a clip-on chuck and extension hose long enough to allow you to stand to one side and NOT in front of or over the tire assembly. Use a safety cage if available. Do not over inflate tires.
- Do not weld on or heat a rim. High heat can weaken and/or warp the rim and damage the tire. Air pressure inside the tire can increase enough to cause an explosion.

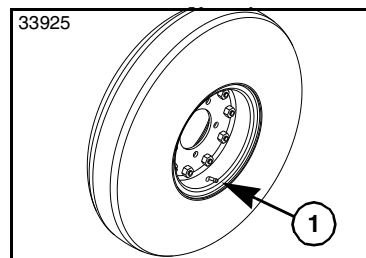

Air Filled Airplane Tires with Split Rims
Figure 5-1

1. Check tires for low air pressure, missing nuts, missing lug bolts, wear, separated rubber, and bent, broken, or cracked wheel rims.
2. Inflate air filled tires to the proper pressure. Refer to “**Tire Inflation Chart**” on page 65.

Section 5: Maintenance & Lubrication

Refer to Figure 5-1 on page 44:

- Replace wheel rims and tires as needed with genuine Land Pride parts. Do not loosen split rim hardware (#1) until all air pressure in the tire has been removed.

Gearbox Driveline Shielding

DANGER

To prevent serious injury or death:

Tractor power take-off shaft shield, driveline shields, and gearbox shaft shields must be installed and in good working condition to avoid driveline entanglement and projectiles flying off of the driveline.

Shut tractor down before doing any maintenance. Refer to “Tractor Shutdown Procedure” on page 15.

Check that the wing gearbox driveline shielding and center gearbox driveline shielding is undamaged and in working order. Replace any damaged or missing components as needed. Order only genuine Land Pride parts from your local Land Pride dealer.

Wing Gearbox Driveline Shield Access

Refer to Figure 5-2:

- To access the driveline slip clutch and yoke assembly, unsnap latches (#2) on both sides of guard (#1) with a flat bladed screwdriver.
- Slide shaft guard (#1) forward over the driveline to expose the slip clutch and yoke assembly. Do not unhook safety chain (#3).
- When servicing the driveline is completed, return shaft guard (#1) to its original position and secure it to mounting plate (#4) with latches (#2).
- Check safety chain (#3) to make sure it is latched to mounting plate (#4) and shaft guard (#1).

Center Gearbox Driveline Sliding Shield

Refer to Figure 5-3 & Figure 5-4:

- To access the center driveline slip clutch and yoke assembly, push down on latch buttons (#2) and release quickly. The levers (#1) will release and pop up as shown in Figure 5-4.
- With one hand on sliding shield handle (#6), push sliding shield (#5) towards the rear of the cutter until the driveline slip clutch and yoke assembly are exposed. The center driveline is now accessible for servicing.
- When servicing the driveline is completed, return sliding shield (#5) to its original position by pulling on handle (#6).
- Rotate latch levers (#1) down until they click shut.

Refer to Figure 5-5:

- Latches (#1) should clamp tight to secure the guard. If it does not, loosen jam nut (#4) and adjust bolt (#3) up to increase the clamping pressure and down to decrease the clamping pressure.

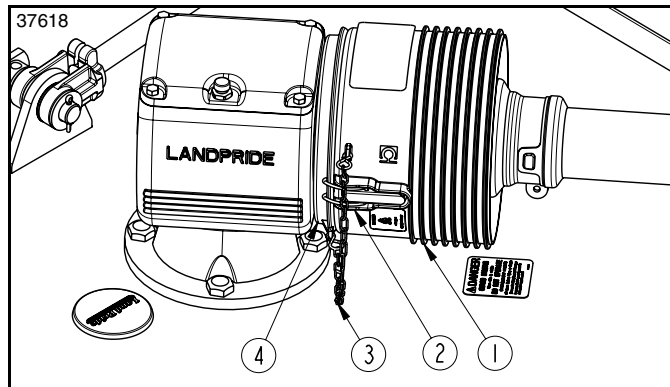

Wing Gearbox Driveline Shield Access
Figure 5-2

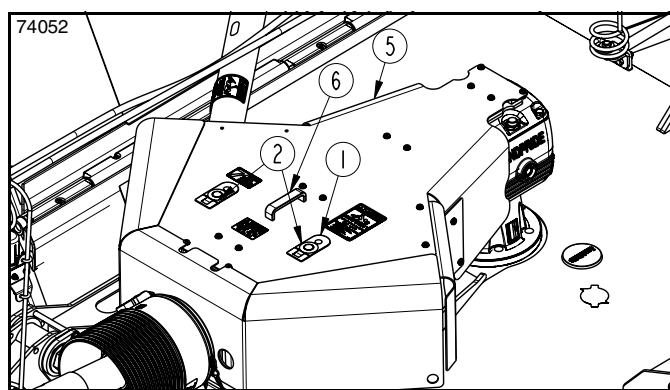

Center Deck Sliding Gearbox Guard (Closed Position)
Figure 5-3

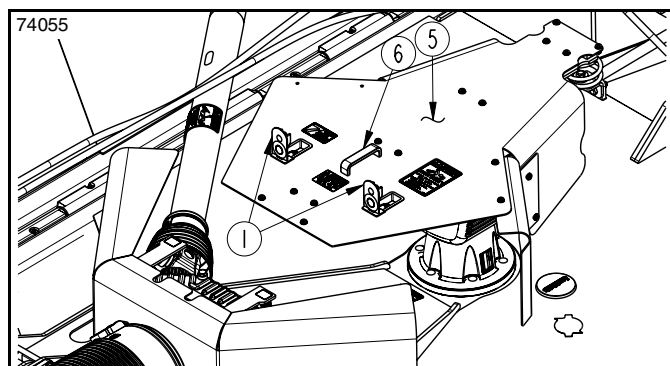

Center Deck Sliding Gearbox Guard (Open Position)
Figure 5-4

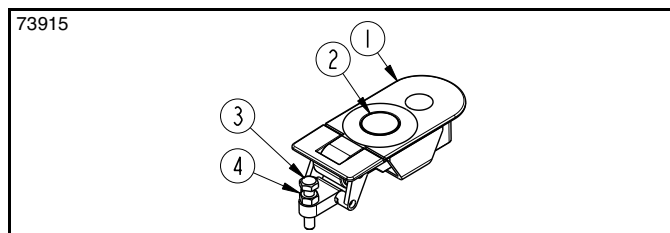

Sliding Shield Latch
Figure 5-5

- Secure bolt (#3) to its new adjusted position by tightening jam nut (#4).

Section 5: Maintenance & Lubrication

Drivelines

Before each use, check that all driveline shields and drivelines are in place, undamaged and in working order. Replace shields and drivelines as needed. Order only genuine Land Pride parts from your local Land Pride dealer.

DANGER

To prevent serious injury or death:

Tractor power take-off shaft shield, driveline shields, and gearbox shaft shields must be installed and in good working condition to avoid driveline entanglement and projectiles flying off of the driveline.

WARNING

To prevent serious injury or death:

Do not operate a broken or bent driveline. Such a driveline will break apart while rotating at high speeds. Always remove the implement from use until the damaged driveline can be repaired or replaced.

Drivelines With Slip Clutches

Friction clutches must be capable of slippage during operation to protect gearboxes, drivelines, and other drive train parts. Friction clutches should be “run-in” prior to initial operation and after periods of inactivity to remove any oxidation from the friction surfaces. Repeat “run-in” at the beginning of each season and when moisture seizes the inner friction plates.

WARNING

To avoid serious injury or death:

- Always follow “Tractor Shutdown Procedure” provided in this manual before dismantling the tractor.
- A slip clutch that has been in use or has slipped for as little as only two or three seconds during run-in may be too hot to touch. Allow a hot clutch to cool before working on it.

IMPORTANT: Prior to initial operation and after 30 days of inactivity, slip friction disks to remove oxidation and moisture. Moisture allows disks to slip easily. Oxidation can prevent disk from slipping causing driveline damage. This damage is NOT covered under the warranty.

Clutch Run-in

Refer to Figure 5-6:

1. Using a pencil or other marker, scribe a line across the exposed edges of the clutch plates and friction disks.
2. Carefully loosen each of the 8 spring retainer nuts by exactly two revolutions. It will be necessary to hold the hex end of the retainer bolt in order to **count the exact number of revolutions**.
3. Make sure the area is clear of all bystanders and machine is safe to operate.

4. Start tractor and engage power take-off drive for 2-3 seconds to permit slippage of the clutch surfaces. Disengage power take-off, then re-engage a second time for 2-3 seconds. Disengage power take-off, shut off tractor, and remove key. Wait for all components to stop before dismantling from tractor.
5. Inspect clutch and ensure that the scribed markings made on the clutch plates have changed position. Slippage has not occurred if any two marks on the friction disk and plate are still aligned. A clutch that has not slipped must be disassembled to separate the friction disk plates. See “Clutch Disassembly, Inspection & Assembly” below.
6. Tighten each of the 8 spring retainer nuts on the clutch housing exactly two revolutions to restore clutch to original setting pressure.
7. Allow clutch to cool to ambient temperature before operating again. Clutch is now ready for use.
8. The clutch should be checked during the first hour of cutting and periodically each week. An additional set of scribe marks can be added to check for slippage. See Figure 5-8 to adjust spring length.

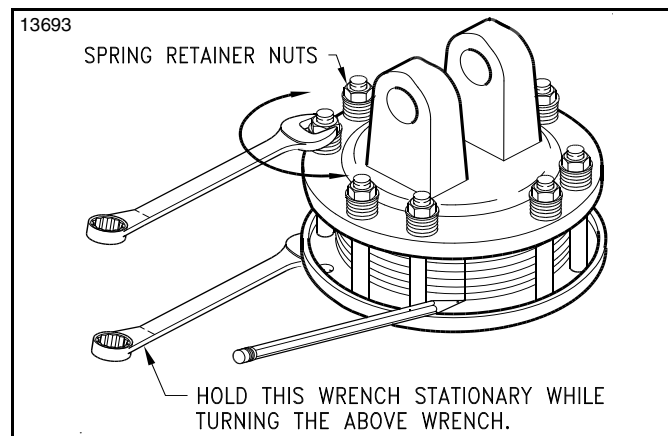

Clutch Run-In
Figure 5-6

Clutch Disassembly, Inspection & Assembly

Refer to Figure 5-7:

If the clutch run-in procedure performed above indicated that one or more friction disks did not slip, then the clutch must be disassembled to separate the friction disks.

Disassembly

IMPORTANT: Not all clutches are assembled the same with the same number of components. Be sure to keep track of order and orientation of your clutch components during disassembly.

Disassembly of clutch is simply a matter of first removing spring retainer nuts (#1), springs (#2), and bolts (#3) from the assembly. Each friction disk (#4) must then be separated from the metal surface adjacent to it.

Section 5: Maintenance & Lubrication

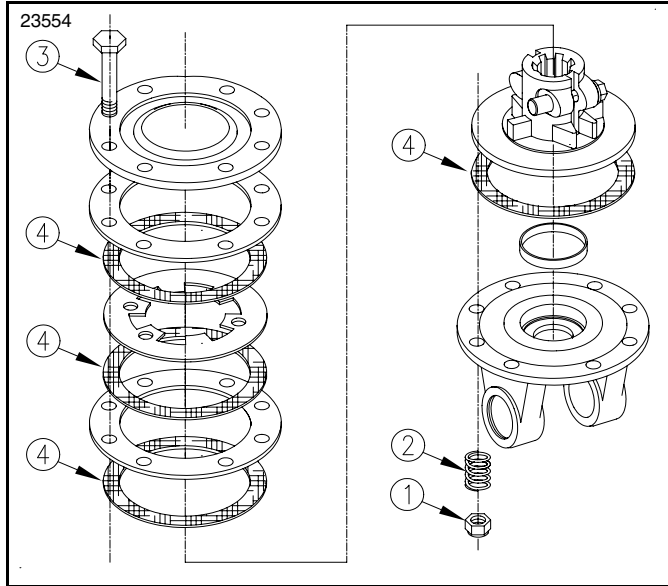

Clutch Assembly
Figure 5-7

Inspection

Inspect all parts for excessive wear and condition. Clean all parts that do not require replacement. The original friction disk thickness is 1/8" (3 mm) and should be replaced if thickness falls below 3/64" (1 mm). If clutches have been slipped to the point of "smoking," the friction disks may be damaged and should be replaced. Heat build-up may also affect the yoke joints.

Assembly

Reassemble each friction disk (#4) next to the metal plate it was separated from. Install bolts (#3) through end plates and intermediate plates as shown. Place springs (#2) over the bolts and secure with nuts (#1).

Refer to Figure 5-8:

Progressively tighten each spring retainer bolt until correct spring height "A" is reached.

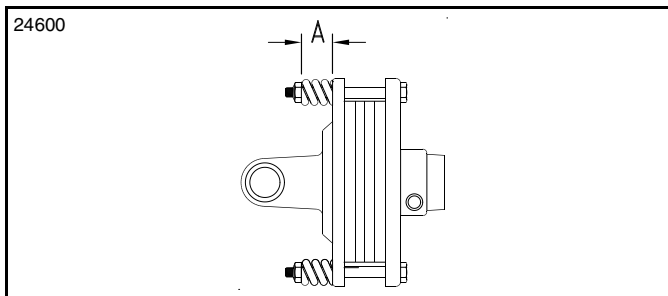

Driveline No.	Driveline Location	PTO Speed	Cat No.	"A" Dimension Spring Height
826-818C	Center	540/1000	4	1.32" (33.5 mm)
826-811C	Wing	540/1000	4	1.32" (33.5 mm)
826-812C	Wing	540/1000	5	1.32" (33.5 mm)

Clutch Spring Adjustment
Figure 5-8

Cutter Blades

Always inspect cutting blades before each use. Make certain they are properly installed and in good working condition. Never try to straighten a bent blade. Small nicks can be ground out when sharpening. For any blade that is damaged, worn, bent, or excessively nicked, replace with genuine Land Pride blades only. Refer to page 48 and page 49 when ordering Land Pride replacement blade components.

DANGER

To avoid serious injury or death:

- Always disconnect driveline from the tractor before servicing the drivetrain and components powered by the drivetrain. A person can become entangled in the drivetrain if the tractor is started and the power take-off is engaged.
- Always secure equipment with solid, non-concrete supports before working under it. Never go under equipment supported by concrete blocks or hydraulics. Concrete can break, hydraulic lines can burst, and/or hydraulic controls can be actuated even when power to hydraulics is off.

WARNING

To avoid serious injury or death:

- Do not operate cutter with blades that are out-of-balance, bent, excessively worn, excessively nicked, or with blade bolts that are excessively worn. Such blades can break loose at high speeds.
- Do not attempt to straighten a bent blade or weld on a blade. Do not attempt to modify a blade such as hard surfacing, heat treating, cold treating, or by any other method. Always replace blades with genuine OEM blades to assure safety.
- Wait for blades to come to a complete stop before accessing blade bolts through blade bolt access hole.
- Wear eye protection and gloves while inspecting, removing, sharpening, and replacing a blade.

IMPORTANT: Cutting blades must be replaced in mating pairs. Not replacing both blades will result in an out-of-balance condition that will contribute to premature bearing breakdown on the spindle hub and create structural cracks in the cutter housing.

Continue on next page.

Section 5: Maintenance & Lubrication

Remove cutting blades and sharpen or replace as follows:

1. Secure cutter deck in the up position with solid, non-concrete supports before servicing underside of cutter.
2. Shut tractor down properly before dismounting. Refer to **“Tractor Shutdown Procedure”** on page 15.
3. Disconnect main driveline from the tractor.

Refer to Figure 5-9 on page 48:

4. Remove rubber plug (#11). Rotate dishpan (#4) until blade bolt (#1) aligns with access hole (A).
5. Unscrew locknut (#3) to remove cutter blade (#10). Blade bolt (#1) is keyed and will not turn freely.
6. Both blades should be sharpened at the same angle as the original cutting edge and must be replaced or re-ground at the same time to maintain proper balance in the cutting unit. The following precautions should be taken when sharpening blades:
 - a. Do not remove more material than necessary.
 - b. Do not heat and pound out a cutting edge.
 - c. Do not grind blades to a razor edge. Leave a blunt cutting edge approximately 1/16" (2 mm) thick.
 - d. Always grind cutting edge so end of blade remains square to cutting edge and not rounded.
 - e. Do not sharpen back side of blade.
 - f. Both blades should weigh the same with not more than 1 1/2 oz. (0.04 kg) difference. Unbalanced blades will cause excessive vibration which can damage gearbox bearings and create structural cracks.

Refer to Figure 5-11:

7. Carefully check cutting edges of blades in relation to blade carrier rotation to ensure correct blade placement. Cutter blades must be installed with cutting edge leading in rotation.

Refer to Figure 5-9 on page 48:

WARNING

To prevent serious injury or death:

A locknut that has been removed can lose its thread locking properties. Reusing a used locknut can result in a thrown blade. Always use a new locknut when installing blades.

IMPORTANT: Examine blade bolts and their flat washers for excessive wear and replace if worn.

8. Insert blade bolt (#1) through blade (#10), dishpan (#4), and flat washer (#2). Secure blade with a new locknut (#3) and torque to 450 ft-lbs (610 N·m).
9. Replace rubber plug (#11).
10. Reconnect main driveline to tractor power take-off.

72288

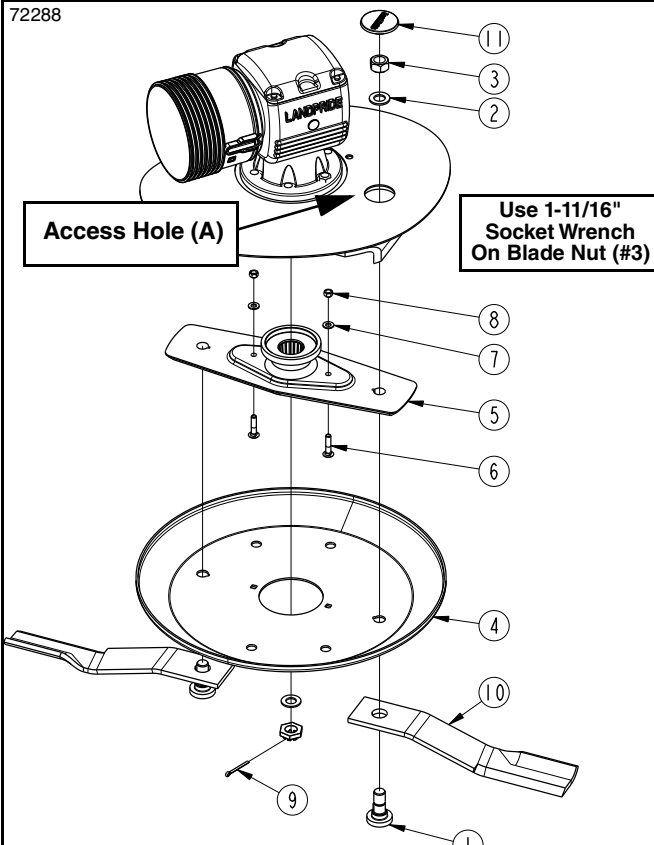

Forged Bar With Bolt-on Dishpan

#	Part No.	Part Description
	318-586A	BLADE BOLT KIT (Includes items 1, 2, & 3 below)
1	802-277C	BLADE BOLT
2	804-147C	WASHER FLAT 1
3	803-170C	NUT HEX TOP LOCK
4	331-507D	BOLT ON DISHPAN
5	334-053H	DIAMOND BLADE BAR
6	802-250C	1/2 - 13 X 2 1/4 GR5 BOLT
7	804-016C	WASHER FLAT 1/2"
8	803-342C	NUT HEX TOP LOCK 1/2 - 13
9	805-105C	PIN COTTER 1/4 x 2 1/2
10	820-722C	CUTTER BLADE 1/2x4x23 CW LH WING
10	820-721C	CUTTER BLADE 1/2x4x29 CCW CENTER
10	820-720C	CUTTER BLADE 1/2x4x23 CCW RH WING
11	840-273C	PLUG LP 3" ID RUBBER

Forged Bar With Bolt-on Dishpan Assembly
Figure 5-9

Section 5: Maintenance & Lubrication

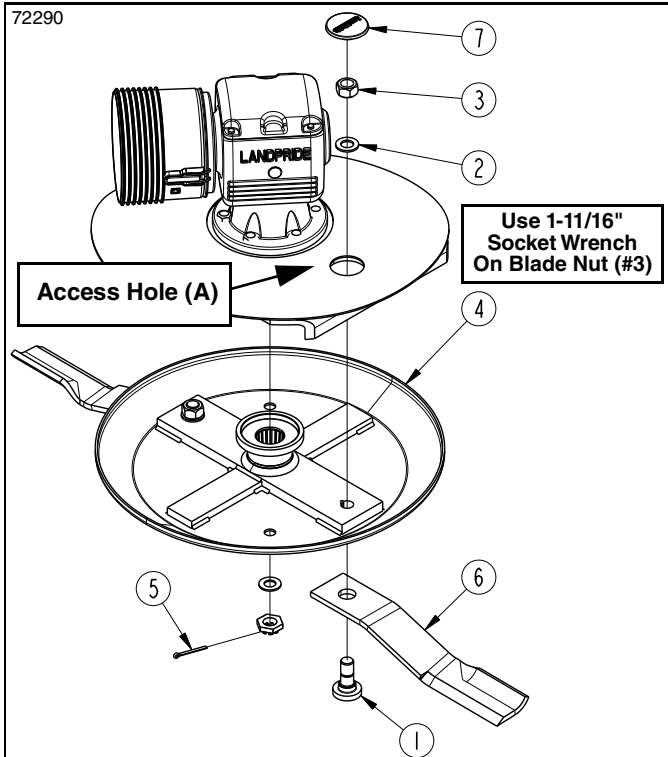

Welded Dishpan Assembly

#	Part No.	Part Description
	318-586A	BLADE BOLT KIT (Includes items 1, 2, & 3 below)
1	802-277C	BLADE BOLT
2	804-147C	WASHER FLAT
3	803-170C	NUT HEX TOP LOCK
4	330-970H	DISHPAN WELDMENT
5	805-105C	PIN COTTER 1/4 x 2 1/2
6	820-722C	CUTTER BLADE 1/2x4x23 CW LH WING
6	820-721C	CUTTER BLADE 1/2x4x29 CCW CENTER
6	820-720C	CUTTER BLADE 1/2x4x23 CCW RH WING
7	840-273C	PLUG LP 3" ID RUBBER

**Welded Dishpan Assembly
Figure 5-10**

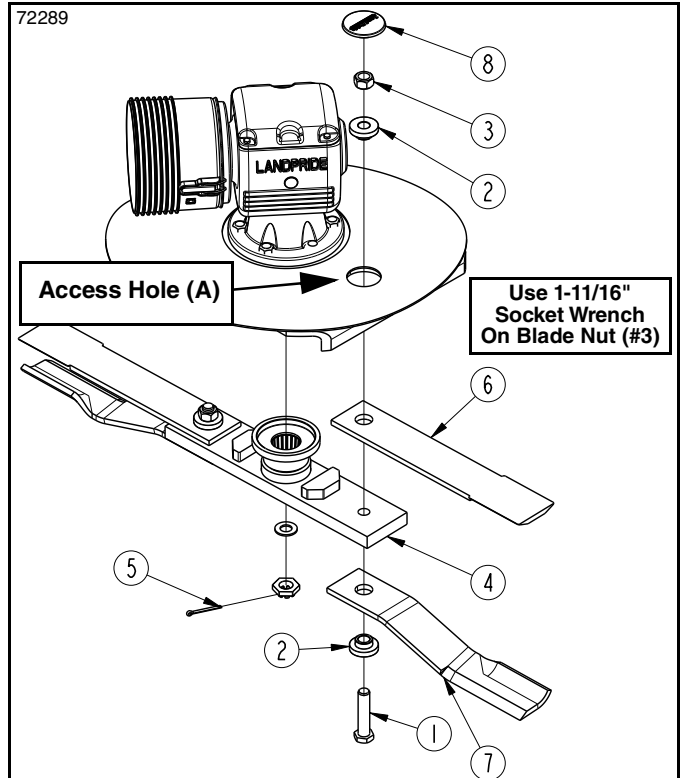

Shredder Kit Assembly

#	Part No.	Part Description
1	802-277C	BLADE BOLT 1- 8 GR8
2	318-309D	BLADE BUSHING
3	803-168C	NUT HEX TOP LOCK 1 - 8
4	330-398H	BLADE BAR WELDMENT 18.5 C/C FLAT (for right-hand and left hand wing)
4	330-227H	BLADE BAR WELDMENT 42.5 C/C FLAT (for center deck)
5	805-105C	PIN COTTER 1/4 x 2 1/2
6	820-217C	CUTTER BLADE 1/2x4x22.5 FLAT (for both wings and center deck)
7	820-722C	CUTTER BLADE 1/2x4x23 CW LH WING
7	820-720C	CUTTER BLADE 1/2X4X23 CCW (for right-hand wing & center deck)
8	840-273C	PLUG LP 3" ID RUBBER

**Shredder Kit Assembly
Figure 5-12**

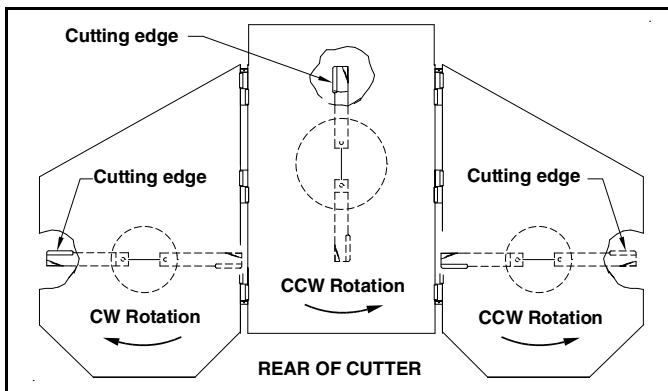

**Direction of Blade Rotation
Figure 5-11**

Section 5: Maintenance & Lubrication

Hitch Wear Points

Before each use, check the wear points for the specific hitch on your cutter. Replace worn hitch components as needed. Order only genuine Land Pride parts from your local Land Pride dealer.

Swivel Clevis Hitch Wear Point

Refer to Figure 5-13:

On the Swivel Clevis Hitch, check plate (#1) for excessive wear around underside of radius by hitch pin hole. If the thickness of plate (#1) is worn down to 9/16" (14 mm) or less at the hitch pin hole, the hitch must be replaced.

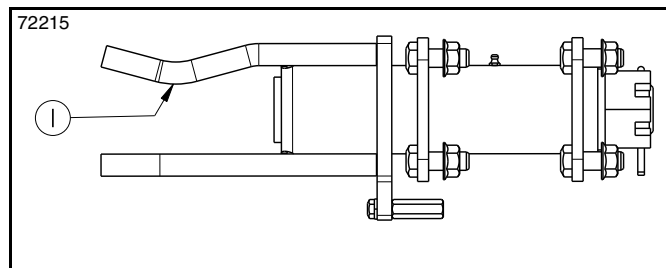

**Swivel Clevis Hitch Wear Point
Figure 5-13**

LP Performance Hitch Wear Points

Refer to Figure 5-14:

On the LP Performance Hitch, check plate (#1) for excessive wear. If the thickness of plate (#1) is worn down to 1/2" (13 mm) or less at the hitch pin hole, the hitch must be replaced.

Check for excessive wear on flat washer (#2). Replace as needed.

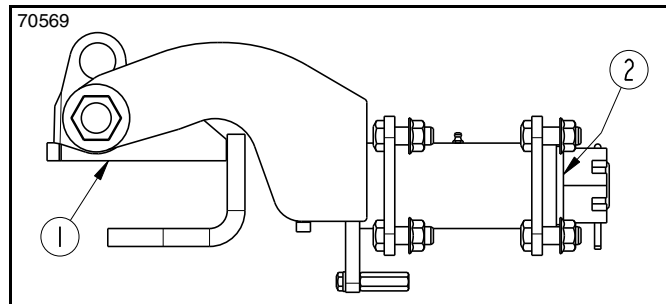

**LP Performance Hitch Wear Points
Figure 5-14**

Bar-Tite Hitch Wear Points

Refer to Figure 5-15:

On the Bar-Tite Hitch, check plates (#1 & #2) for excessive wear. If the thickness of the plates are worn down to 3/8" (10 mm) or less at the bolt hole, the hitch must be replaced.

Check for excessive wear on flat washer (#3). Replace as needed.

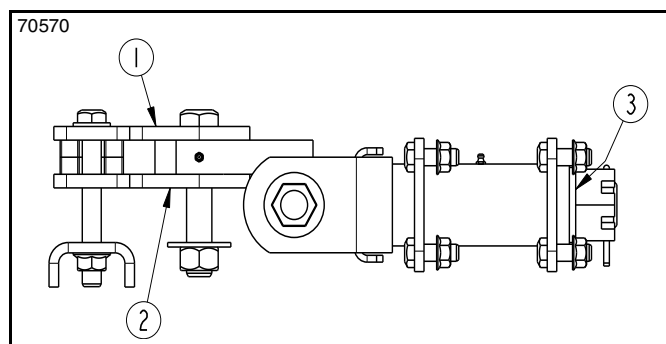

**Bar-Tite Hitch Wear Points
Figure 5-15**

Section 5: Maintenance & Lubrication

Skid Shoes

This Rotary Cutter comes standard with two center deck skid shoes. Alternate mounting locations on the underside of the center deck allow for the relocation of skid shoes. Each wing comes equipped with one skid shoe. Check skid shoes for wear and replace if needed. Order only genuine Land Pride parts from your local Land Pride dealer.

WARNING

To prevent serious injury or death:

Excessive wear on skid shoes may cause inadequate operation of cutter and create a safety hazard.

Wing Skid Shoes

Refer to Figure 5-16:

IMPORTANT: Excessive wear on skid shoes can weaken cutter side panels and cause damage requiring extensive repairs. Always replace skid shoes at the first sign of wearing thin.

Replace wing skid shoes as follows:

1. Remove 3/8" hex whiz nuts (#3), 3/8" plow bolts (#2), and left-hand skid shoe (#1) as shown.
2. Plow bolts (#2) should be checked for wear and replaced if necessary.
3. Attach new left-hand skid shoe (#1) to cutter with 3/8" plow bolts (#2) and secure with 3/8" hex whiz nuts (#3). Tighten bolts to the correct torque by referring to the "Torque Values Chart" on page 65.
4. Repeat steps 1 - 3 for the right-hand wing.

Center Skid Shoes

Refer to Figure 5-17:

Replace or relocate center skid shoes as follows:

1. Remove 5/8"-11 hex flange nuts (#3), 5/8" -11 x 4" GR5 bolts (#2), and left-hand center skid shoe (#1) from its corresponding center skid shoe mount.
2. Attach new skid shoe (#1) to cutter with existing 5/8" bolts (#2), and secure with existing 5/8" hex flange nuts (#3). Tighten bolts to the correct torque.
3. Repeat steps 1 & 2 for right-hand center skid shoe.

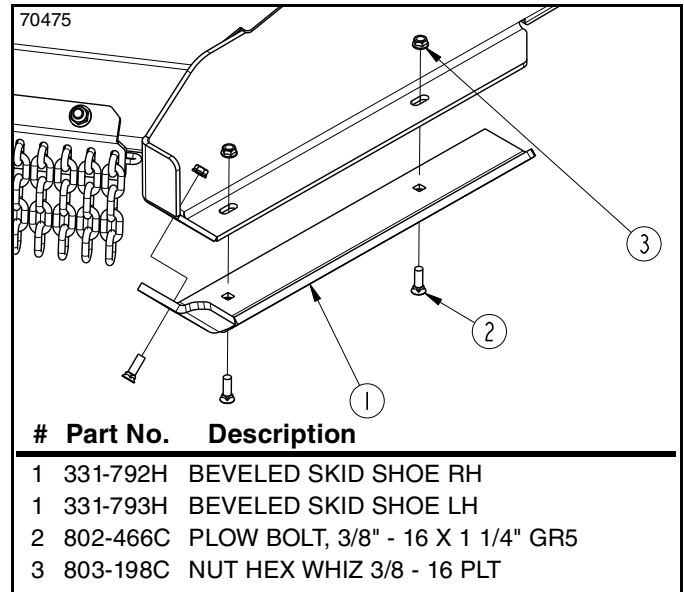

Wing Skid Shoes
Figure 5-16

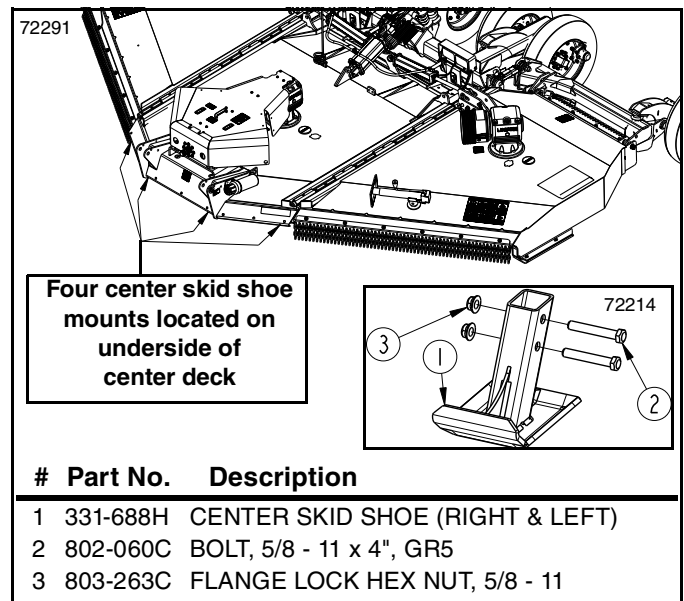

Center Skid Shoes
Figure 5-17



Stroke Control Flip Spacer Replacement

Overtime, the stroke control flip spacers may show signs of wear such as bending or gouging. When the spacers become difficult to close or they open too easily, then it is time to order replacement parts. Order only genuine Land Pride parts from your local Land Pride dealer.

The flip spacers included on your cutter are not all the same. When ordering new parts, compare damaged flip spacers to a matching illustration below to ensure ordering the right part. Additional assembly components are also listed below.

IMPORTANT: Worn or bent flip spacers can open too easily or become difficult to close, possibly resulting in spacers self-shifting from a fully-closed or fully-open position. This can potentially cause damage to the lift cylinder and/or flip spacers.

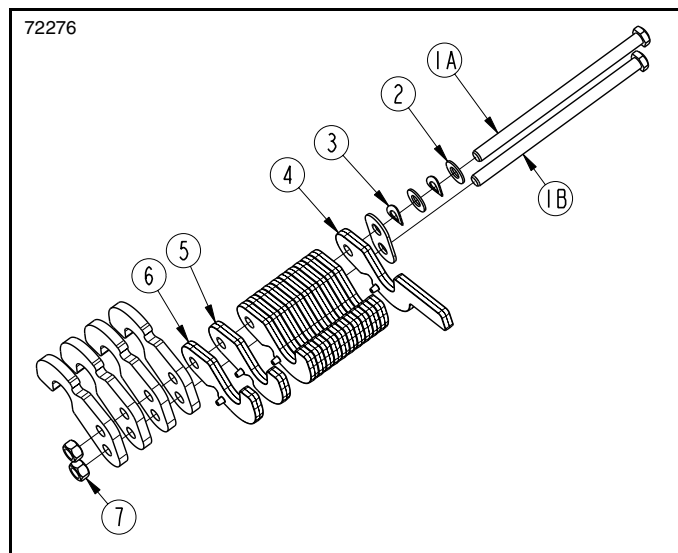

Stroke Control Flip Spacer Assembly
Figure 5-18

Flip Spacer Replacement

Refer to Figure 5-18:

1. Remove hex lock-nut (#7) from 5/8-11 GR5 bolt (#1A).
2. Carefully remove 5/8-11 GR5 bolt (#1A) from alternating flip spacers (#5 & #6), leaving both wave washers (#3) and both flat washers (#2) on bolt (#1A).
3. Remove any worn flip spacers (#5 & #6) and replace with new flip spacers, ensuring they are alternating in sequence.
4. Replace removed 5/8-11 GR5 bolt (#1A), ensuring both wave washers (#3) and both flat washers (#2) are on bolt (#1A).
5. Secure 5/8-11 GR5 bolt (#1A) by attaching a new hex lock-nut (#7). Tighten until flip spacers will not pivot freely, then back off 1/2 to 1 turn.

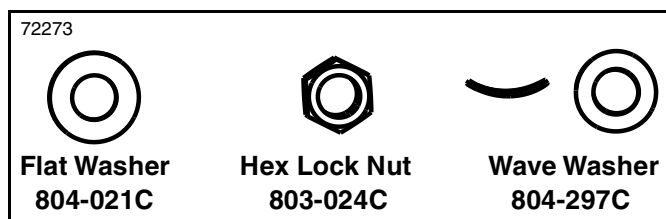
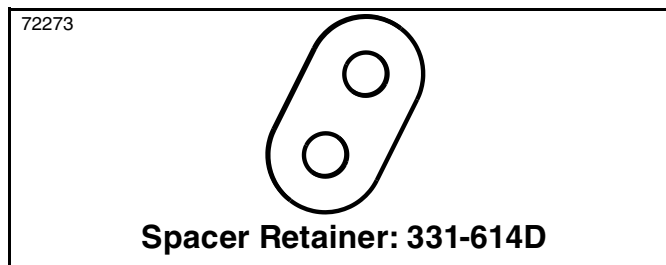
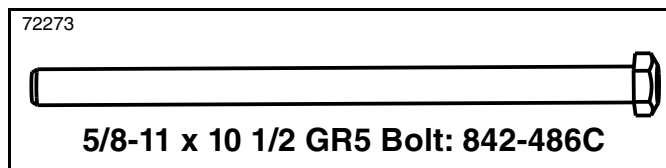
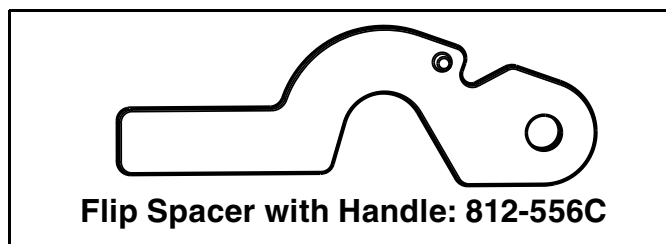
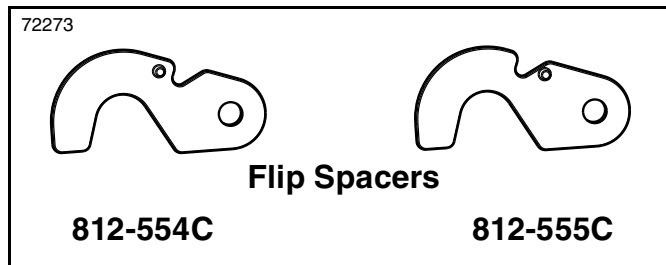



Section 5: Maintenance & Lubrication

Chain Guards

Refer to Figure 5-19:

Before each use of the cutter, ensure all ten chain guard sections (1-10) are present and undamaged. Replace any damaged or missing chain guard components as needed. Order only genuine Land Pride parts from your local Land Pride dealer.

DANGER

To prevent serious injury or death:

Rotary Cutters have the ability to discharge objects at high speeds; therefore, the use of front & rear safety guards is mandatory with this cutter. Double row chain guards should be used when cutting along roadways and in areas where people may be present. Stop blade rotation if bystanders are in or around the area. It is recommended that a safety shield be placed between the operator and cutter on an open air tractor.

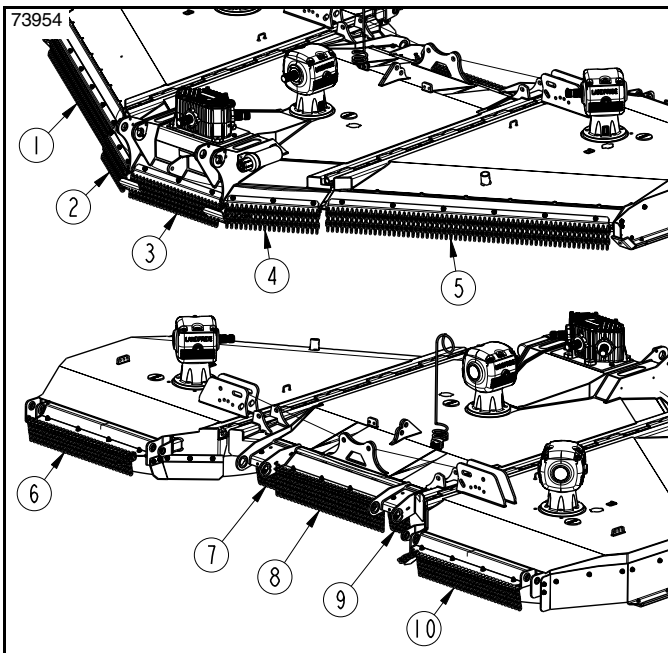

Front and Rear Chain Guard (Tires, Axles, Hydraulics, & Drive Components are Omitted for Clarity)
Figure 5-19

Long-Term Storage

Clean, inspect, service, and make necessary repairs to the cutter when storing it for long periods and when storing it at the end of a working season. This will ensure the cutter is ready for field use the next time you hook-up to it.

DANGER

To avoid serious injury or death:

- Always disconnect driveline from the tractor before servicing the drivetrain and components powered by the drivetrain. A person can become entangled in the drivetrain if the tractor is started and the power take-off is engaged.

- Always secure equipment with solid, non-concrete supports before working under it. Never go under equipment supported by concrete blocks or hydraulics. Concrete can break, hydraulic lines can burst, and/or hydraulic controls can be actuated even when power to hydraulics is off.

- Clean off any dirt and grease that may have accumulated on the cutter and moving parts. Scrape off compacted dirt from the bottom of deck and then wash surface thoroughly with a garden hose. A coating of oil or touch up paint may also be applied to the lower deck area to minimize oxidation.
- Check blades and blade bolts for wear and replace if necessary. See “Cutter Blades” on page 47.
- Inspect for loose, damaged, or worn parts and adjust or replace as needed.
- Repaint parts where paint is worn or scratched to prevent rust. Ask your Land Pride dealer for aerosol touch-up paint. Paint is also available in touch-up bottles with brush, quarts, and gallon sizes by adding TU, QT, or GL to the end of the aerosol part number.

Land Pride Aerosol Touch-up Paint	
Part No.	Part Description
821-011C	PAINT LP BEIGE SPRAY CAN
821-070C	PAINT LP BLACK SPRAY CAN
821-054C	PAINT MEDIUM RED SPRAY CAN
821-058C	PAINT GREEN SPRAY CAN
821-066C	PAINT ORANGE SPRAY CAN
821-080C	PAINT GALVANIZED SPRAY CAN

- Replace all damaged or missing guarding & decals.
- Lubricate as noted in “Lubrication Points” starting on page 54.
- Store cutter on a level surface in a clean, dry place. Inside storage will reduce maintenance and make for a longer cutter life.
- Follow “Unhook Rotary Cutter” instructions on page 27 when disconnecting tractor from cutter.

Ordering Replacement Parts

Land Pride offers equipment in factory standard Beige and factory standard Galvanized with black highlights. This implement may also be purchased in Orange, Green, Yellow or Red.





When ordering an optional color, the suffix number corresponding to the color must be added at the end of the part number. Parts ordered without the suffix number will be supplied in factory standard colors.

- | | |
|---------------------|---------------------|
| 81 Green | 85 Black |
| 82 Orange | 86 Yellow |
| 83 Red | |

For example, if you are ordering a replacement part with part number 555-555C and the existing part is orange, then add the suffix 82 to the end of the number to make the part number read 555-555C82.

Section 5: Maintenance & Lubrication

Lubrication Points

<p>Lubrication Legend</p>	 <p>Multi-purpose spray lube</p>	 <p>Multi-purpose grease lube</p>	 <p>Multi-purpose oil lube</p>	 <p>50 hrs</p>	<p>Intervals in hours at which lubrication is required</p>
---------------------------	---	--	---	---	--

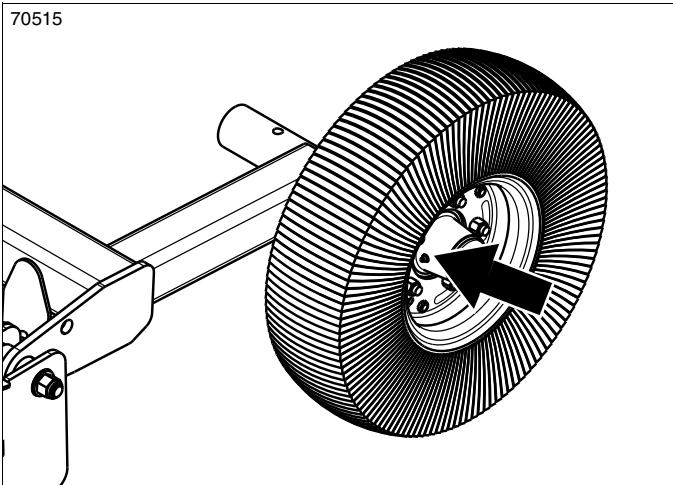

		150 Hours	Repack Annually
--	---	------------------	------------------------

Axle Hub Bearing

1 zerk per wheel (zerk can be on either side)



Type of Lubrication: Multi-Purpose Grease

Grease wheel bearings every 150 hours.

Quantity = 2 pumps

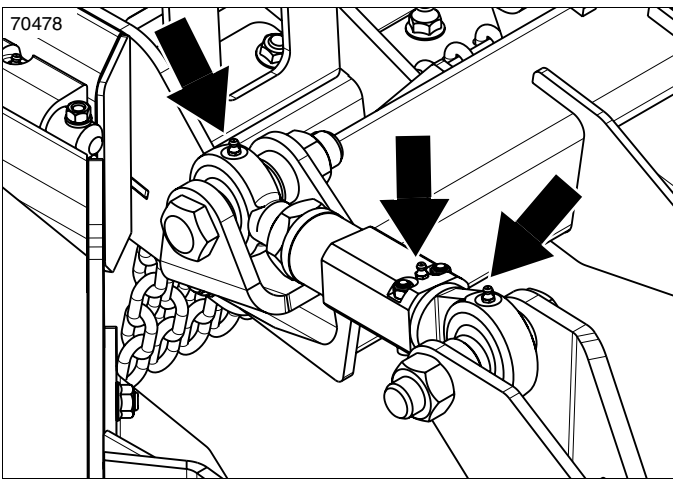
Repack wheel bearings annually.



		50 Hours
---	--	-----------------

Adjustable Turnbuckle

3 zerks

Type of Lubrication: Multi-Purpose Grease

Grease both left & right hand side turnbuckles every 50 hours.

Quantity = As required

Grease with wings folded up to remove pressure on turnbuckle and allow grease to reach more areas.

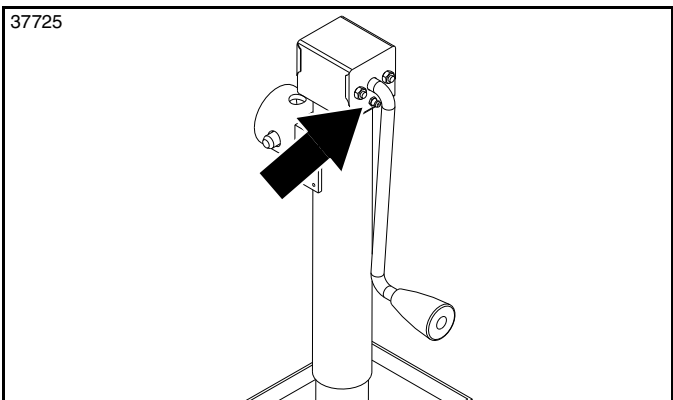

	As Needed
--	------------------

Park Jack

1 zerk

Type of Lubrication: Multi-purpose Grease

Frequency = As needed and when unhooking for longterm storage

Quantity = As required

Section 5: Maintenance & Lubrication

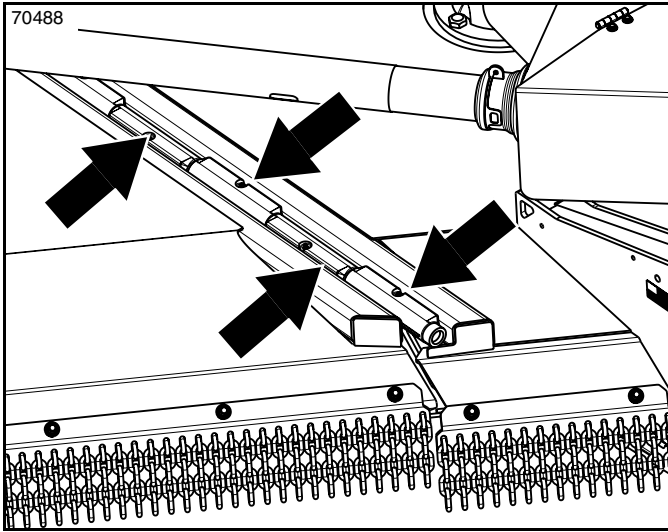

	As Needed
--	------------------

Deck Hinges

20 zerks

Type of Lubrication: Multi-purpose Grease

Frequency = As needed and when unhooking for longterm storage.

Quantity = As required

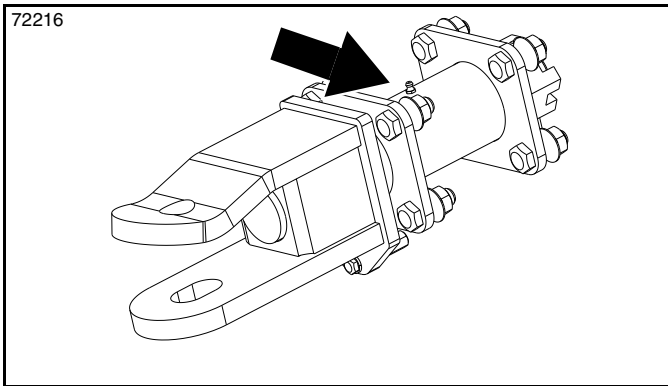

	50 Hours
--	-----------------

Swivel Clevis Hitch (Optional)

1 zerk

Type of Lubrication: Multi-purpose Grease

Frequency = Every 50 hours

Quantity = As required

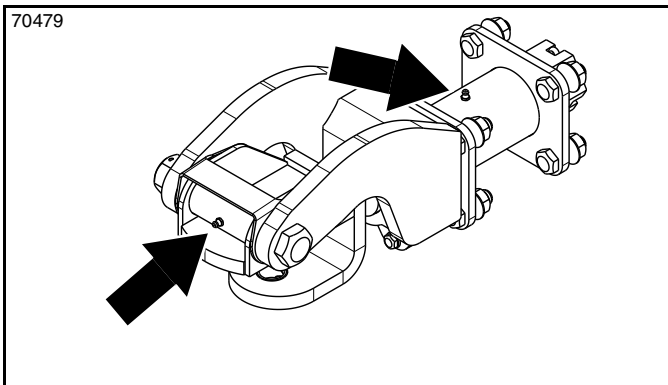

	50 Hours
--	-----------------

LP Performance Hitch (Optional)

2 zerks

Type of Lubrication: Multi-purpose Grease

Frequency = Every 50 hours

Quantity = As required

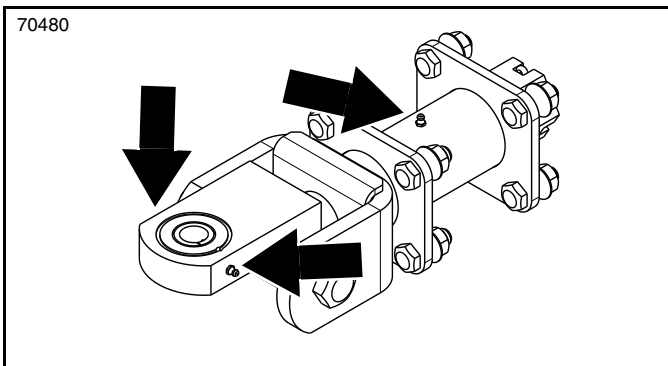

	50 Hours
--	-----------------

Bar-Tite Hitch (Optional)

3 zerks

Type of Lubrication: Multi-purpose Grease

Frequency = Every 50 hours

Quantity = As required



30215

Do Not Overfill

METHOD 1:
SCREW DIPSTICK FULLY IN & THEN UNSCEW TO CHECK LEVEL. OIL LEVEL SHOULD BE BETWEEN THE TWO MARKS ON DIPSTICK. ADD OIL IF BELOW BOTTOM MARK.

METHOD 2:
OIL SHOULD BE LEVEL WITH BOTTOM OF HOLE. ADD OIL THROUGH DIPSTICK HOLE UNTIL OIL RUNS OUT OF PLUG HOLE.

NOTE: Use a suction or siphon pump to drain gearbox of oil when there is not an oil drain plug.

**600 hrs
or
Annually**

Gearbox and Divider Box Lubrication

Change oil after first 50 hours, then change it yearly or every 600 hours.

IMPORTANT: Do not overfill the gearbox and divider box with oil. Oil will expand when hot. Make sure the implement is level and oil is cool before checking oil level.

If oil has been removed from the gearbox, refill gearbox to plug level or full mark on the dipstick. Allow time for air to bleed up from the lower cavity, and then recheck.

Method 1: Unscrew top vented dipstick (#1). Wipe oil from dipstick and screw dipstick in without tightening. Unscrew dipstick and check oil on dipstick. If below bottom level mark, add recommended gear lube through dipstick hole until oil reaches top mark on dipstick. Reinstall vented dipstick and tighten.

Method 2: Remove side oil plug (#2). If oil is below bottom of plug hole, add recommended gear lube through top dipstick hole until oil flows out of side plug hole. Reinstall and tighten side oil plug (#2) and vented dipstick (#1).

Type of Lubrication: 80-90W EP Gear Lube

Quantity = Fill until oil reaches top mark on dipstick or begins to flow out side plug hole in gearbox.

72254

VENTED DIPSTICK

OIL LEVEL PLUG

OIL DRAIN PLUG

Section 5: Maintenance & Lubrication

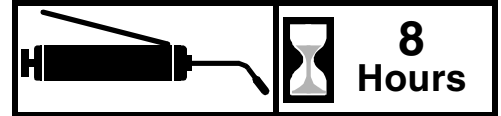
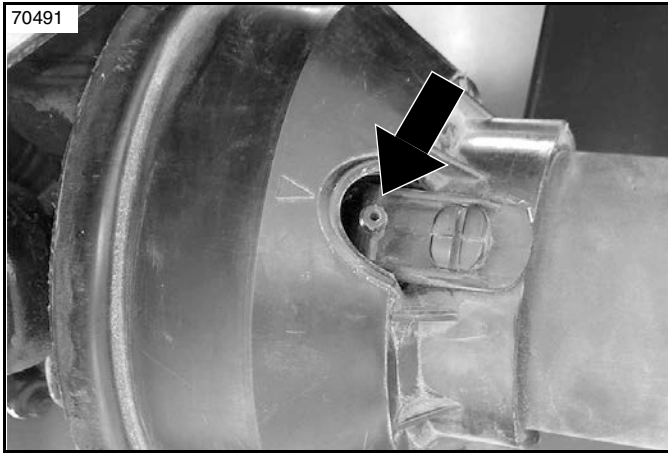

Wing Driveline Shield Grease Point

Type of Lubrication: Multi-purpose Grease

Frequency = Every 8 hours

Quantity = 2-3 Pumps

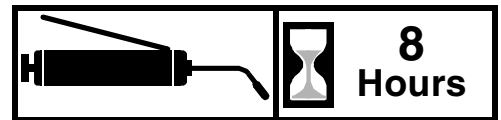
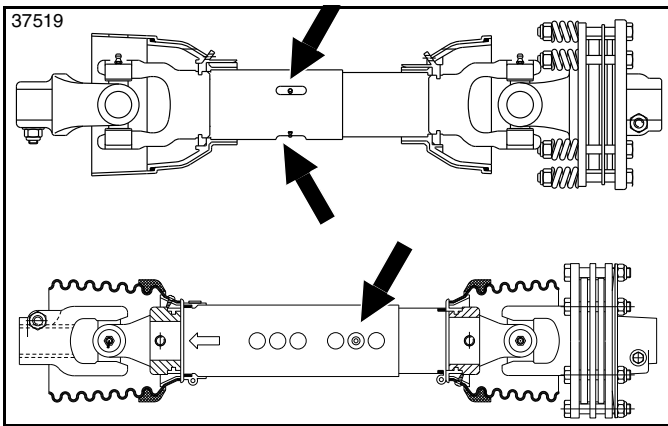

Wing Driveline Profile Tubes

Type of Lubrication: Multi-purpose Grease

Frequency = Every 8 hours

Quantity = Coat Generously

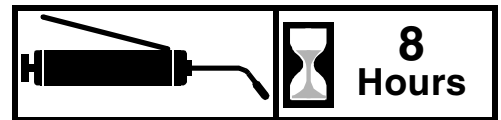
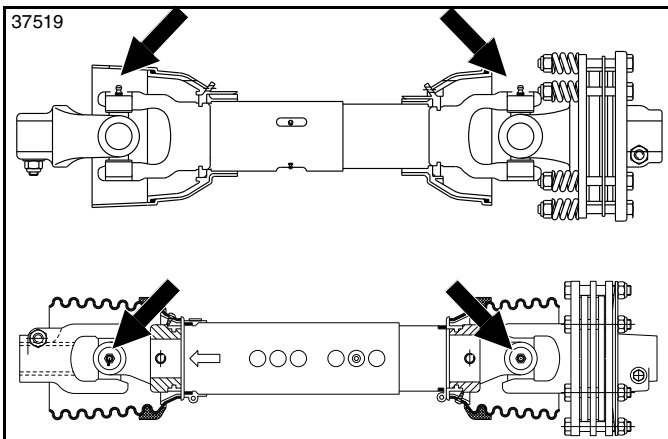

Wing Driveline Joints

Type of Lubrication: Multi-purpose Grease

Frequency = Every 8 hours

Quantity= 2-3 Pumps

Drivelines with external profile tube grease point

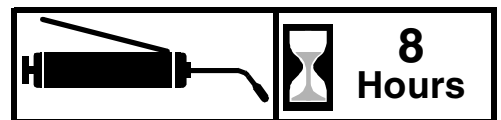
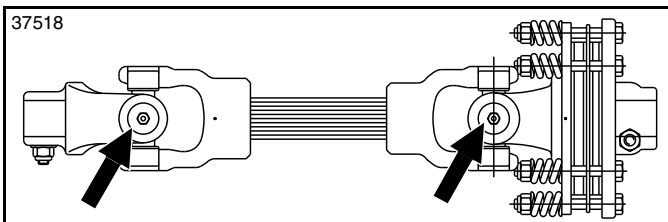

Intermediate Driveline Joints

Type of Lubrication: Multi-purpose Grease

Frequency = Every 8 hours

Quantity= 2-3 Pumps

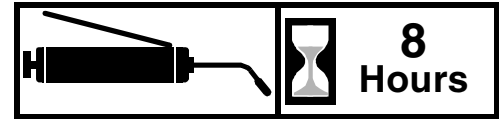
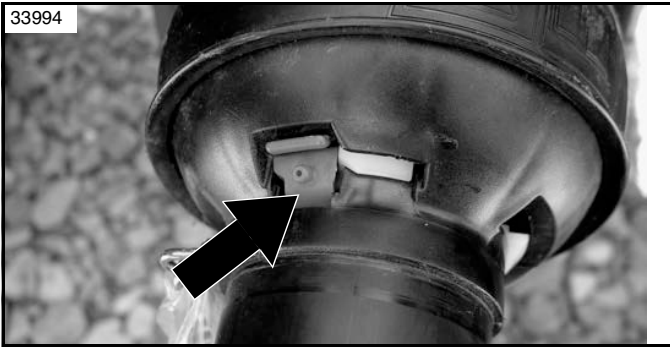

CV Main Driveline Shield Grease Point

Type of Lubrication: Multi-purpose Grease

Frequency = Every 8 hours

Quantity = 2-3 Pumps

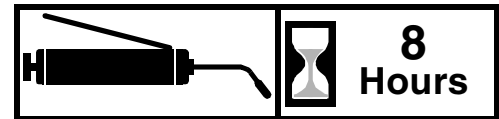
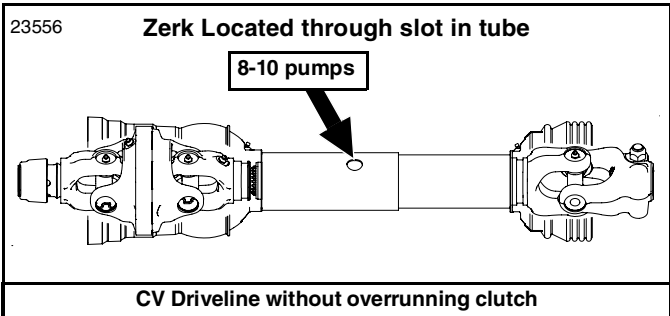

CV Main Driveline Profile Tubes With External Grease Point

Type of Lubrication: Multi-purpose Grease

Frequency = Every 8 hours

Quantity = 8-10 pumps

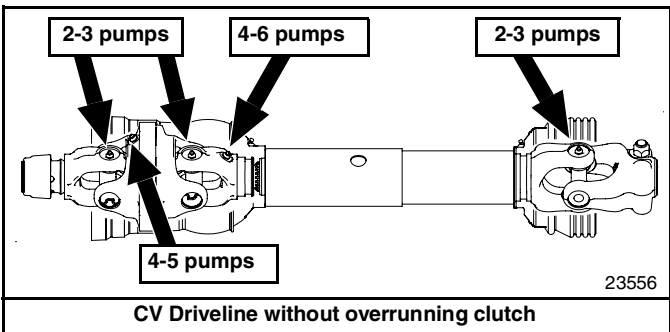
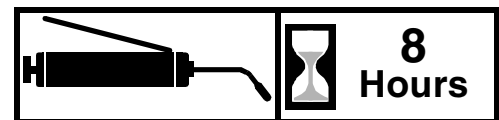
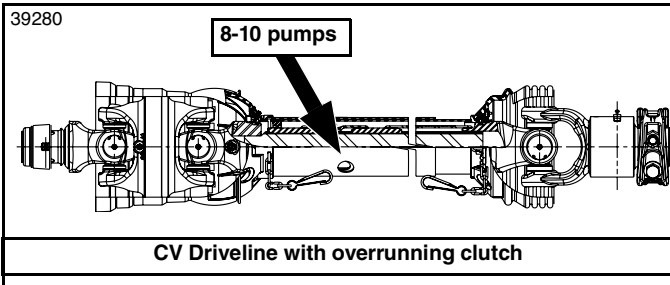

IMPORTANT: To extend the life of the constant velocity joint, extensive lubrication must be performed every 8 hours of operation.

CV Main Driveline Joints

Type of Lubrication: Multi-purpose Grease

Frequency = Every 8 hours

For instructions on how to access grease zerks shown in : See **“Accessing CV Driveline Joints”** on page 59.

- The constant velocity joint should be greased in a straight position forcing grease through the passages and into the cavity. After lubrication, grease should be visible around the ball joints.
- Grease fittings located on the u-joints, driveline shields and overrunning clutch should be lubricated every 8 hours of operation.

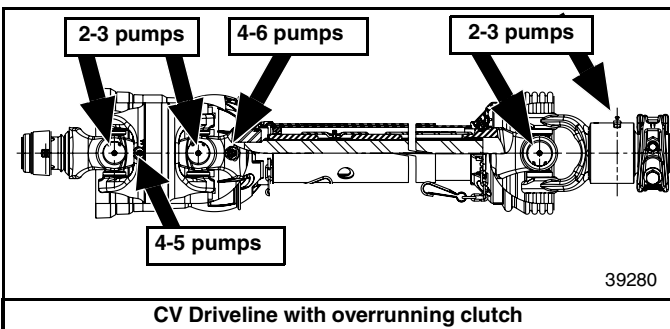

**CV Driveline Joint Access
Figure 5-20**

Section 5: Maintenance & Lubrication

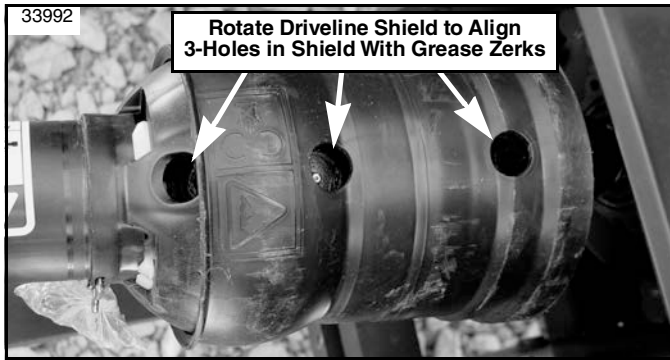

Lubrication Through Three Holes In Driveline Shield
Figure 5-21

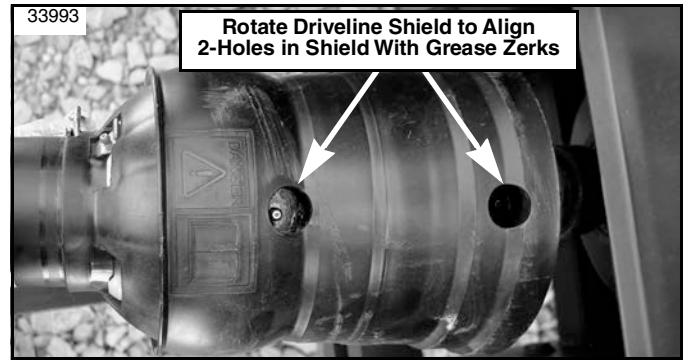

Lubrication Through Two Holes In Driveline Shield
Figure 5-22

Accessing CV Driveline Joints

Refer to “CV Driveline Joint Access” on page 58.

There are two ways the constant velocity driveline joints shown in Figure 5-21 can be accessed for lubrication. One is through holes in the driveline shield and the other is to slide the shields back to expose the grease zerks as shown in Figure 5-25.

Lubrication Through Access Holes

1. Refer to Figure 5-21: Rotate driveline shield until holes in shield align with grease zerks in CV joint.
2. Apply correct type and amount of lubrication. Refer to “CV Main Driveline Joints” on page 58 for quantities and type of lubrication.
3. Refer to Figure 5-22: Rotate driveline shield 180° until holes on opposite side of shield aligns with remaining grease zerks in CV joint.
4. Repeat step 2 above on any grease zerks that were not greased in step 2.
5. Steps 1-2 can be repeated to lubricate universal joint on opposite end of driveline. (Opposite end of driveline has only one grease zerk.)

Lubrication By Sliding Driveline Shields Back

1. Refer to Figure 5-23: With a flathead screwdriver or similar tool, pry top of red locking tab up.
2. Refer to Figure 5-24: Rotate white locking ring counterclockwise to the position shown.
3. Refer to Figure 5-25: Pull back on driveline shielding until CV joint is exposed.
4. Apply correct type and amount of lubrication. Refer to “CV Main Driveline Joints” on page 58 for quantities and type of lubrication.
5. Slide driveline shield back to its operating position.
6. Refer to Figure 5-23: Rotate white locking ring clockwise and press locking tab down until it snaps in place as shown.

Steps 1-6 can be repeated to lubricate universal joint on opposite end of driveline.

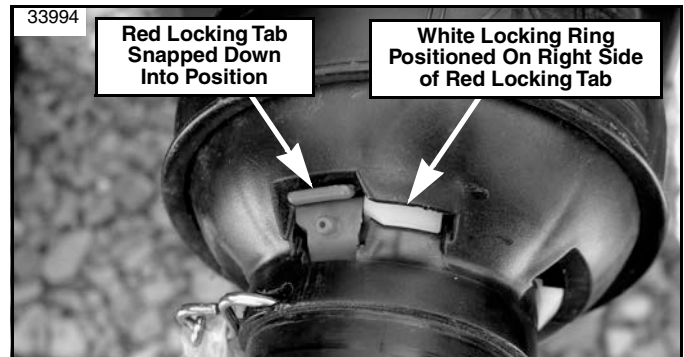

Locked Driveline Shield
Figure 5-23

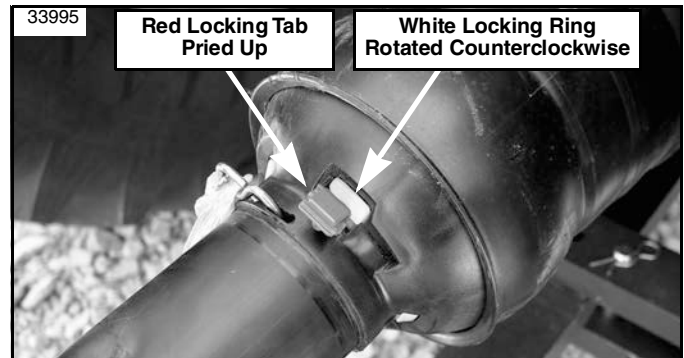

Unlocked Driveline Shield
Figure 5-24

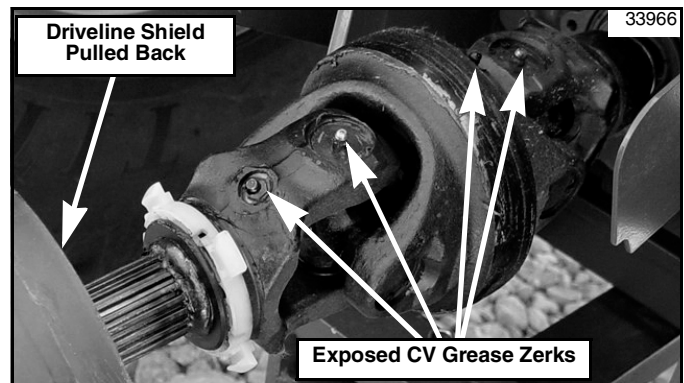

Slide Driveline Shield Back To Expose Grease Zerks
Figure 5-25



RC(M)4715 & RCG(M)4715 Models

Specifications & Capacities	
Horsepower range	55-250 hp (41-186.4 kW)
Gearbox horsepower	540 rpm or 1000 rpm 250hp (186.4 kW) Divider and 210hp (156.6 kW) Center & Wings
Gearbox lubrication	Gear Lube 80-90W EP
Gearbox oil capacity	Splitter: 3.5 pints (1.66 L); Center deck & Wings: 6 pints (2.84 L)
Cutting capacity	4" (10.2 cm)
Machine weight	5,000 lbs. (2268 kg)
Total weight	1860 lbs. (843.7 kg)
Tongue weight	
Blade tip speed	Center Blades & Wing Blades = 16,300 FPM (82.8 mps)
At 540 rpm	Center Blades = 16,300 FPM (82.8 mps) & Wing Blades = 16,000 FPM (81.3 mps)
At 1000 rpm	
Hitch types	Swivel Clevis Hitch, LP Performance Hitch, Bar-Tite Hitch, Ball Hitch, or Pintle Hitch.
Hitch jack	Standard (7,000 lbs.) (3175.1 kg)
Signal lights	LED
7 Pin connector	SAE J560 pin configuration
Cutting width	15'-0" (4.57 m)
Overall width	15'-10" (4.83 m)
Transport width with 21" tires	10'-3" (3.12 m) - Single-acting fold option, 7'-3" (2.21 m) - Dual-acting fold option.
Overall length	16'-3" (4.95 m) - With center deck raised fully up.
Deck height	12" (30.5 cm)
Cutting height	1-1/2" - 16" (3.8 cm - 40.6 cm) - Varies by tire option.
Lift hydraulics	3" x 8" (7.6 cm x 20.3 cm) hydraulic cylinder, hoses, fittings & stroke control spacers.
Wing flex while operating	Max. 20° down, can float up as needed as long as the wheel(s) are still on the ground.
Wing hydraulics	2 1/2" x 12" (6.4 cm - 30.5 cm) hydraulic cylinders, hoses & fittings.
Wing transport protection	Wing Transport Lock Pins
Deck material thickness	10 Gauge (3.4 mm)
Side skirt thickness	1/4" (6 mm) Steel
Skid shoes	Wing Deck: 1 Replaceable skid shoe per wing. Center Deck: 2 Replaceable skid shoes and multiple mounting locations.
Blades - 6 (2 per carrier)	1/2" x 4" (1.3 cm - 10.2 cm) Heat-treated, free-swinging alloy steel with uplift.
Blade overlap	6" (15.2 cm)
Blade bolt	Keyed with hardened flat washer & locknut.
Stump jumper / blade holder	3/16" (5 mm) Thick round dish shaped pan, reinforced with 1" x 4" (2.5 x 10.2 cm) blade bar.
Front & rear guards	Optional single row chain or dual row chain.
Input driveline 540 & 1000 rpm	Cat. 6 with constant velocity u-joint with or without overrunning clutch.
Intermediate driveline	Standard - Category 4 with slip-clutch.
Wing drivelines	Standard - Category 4 with slip-clutch or Category 5 with slip-clutch.
Wheel options	21" (53.3 cm) or 26" (66 cm) Laminated tires 24" (61 cm) Used aircraft, foam filled tires 25.5" (64.8 cm) 20 ply tires, foam filled or pneumatic 29" (73.7 cm) Used aircraft tires
Number of wheels	6 - Wheel option: Four on transport axle and one on each wing axle. 8 - Wheel option: Four on transport axle and two on each wing axle.
Transport axle	Many configurations to choose from.
Hubs	Cast iron five-bolt hubs with tapered roller bearings and 1 3/4" (4.4 cm) shafts.
LP Performance hitch & Bar tite hitch pivot shaft diameter	2 1/4" (5.7 cm)
A-frame tongue	5" x 3" (12.7 cm x 7.6 cm) rectangular tubing

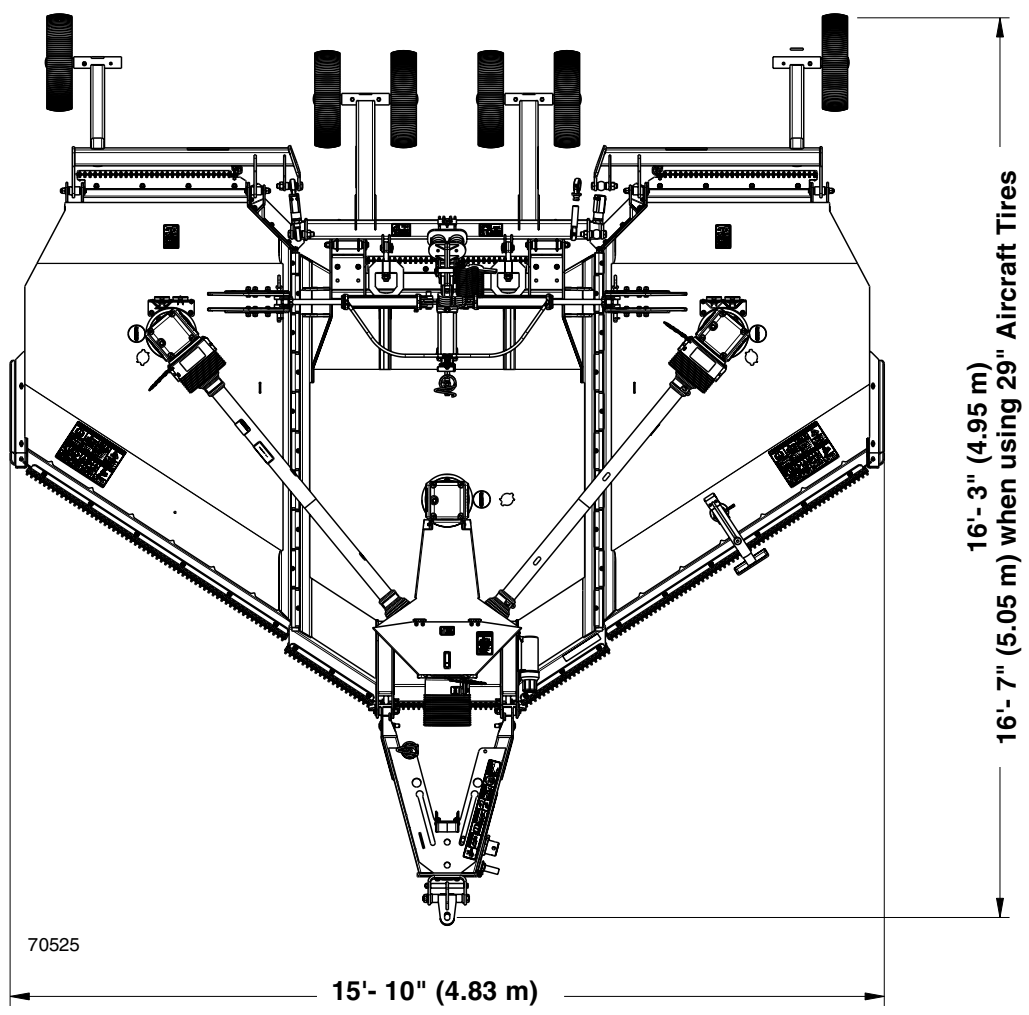
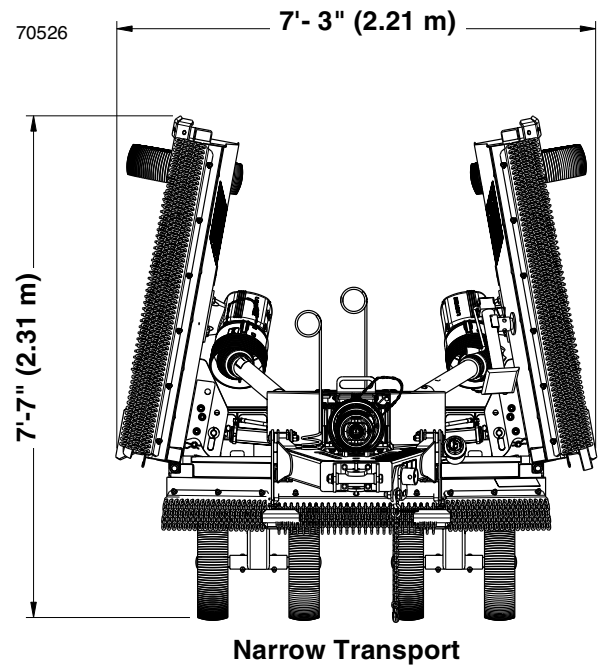
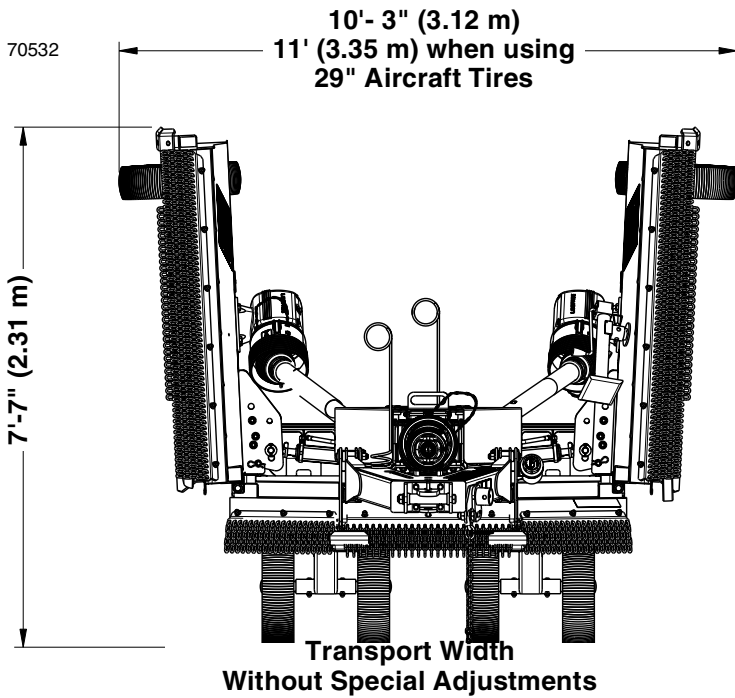



RC(M)4715 & RCG(M)4715 Models

Features	Benefits
Surpassed rugged industry standards	All Land Pride Rotary Cutters have been designed and tested and meet rigorous voluntary testing procedures according to ISO 4254-13.
Factory assembled	Arrives for quick and easy set-up. Minimal time wasted setting or prepping the unit.
7 Year gearbox warranty	Shows confidence in gearbox integrity.
Rugged heavy built gearboxes	Capable of handling heavy cutting applications.
Gearbox seal protection	Gearbox bottom seal protection for longer bearing life.
Sliding guard for splitter gearbox	Sliding guard offers protection and easy access for improved efficiency of splitter gearbox maintenance.
2 Piece driveline shields	Driveline grease zerks are easier to access.
Low hitch weight on tractor tongue	Ideal for smaller hp tractors by reducing the amount of weight on the drawbar.
Narrow A-frame hitch	Allows for a tighter turning radius.
Adjustable park jack angle	Park jack can be adjusted to be perpendicular to the ground.
Adjustable driveline hanger	Serves as support rest for the driveline when the cutter is unhooked from the tractor. Assist operator when attaching driveline to tractor power take-off shaft.
Input driveline: Cat. 6 CV	Driveline is matched just right for tractor capacity. Constant velocity (CV) U-joint allows for 80 degree turns without doing damage to the driveline.
Drivelines with slip-clutches: Cat. 4 intermediate Cat. 4 or Cat. 5 wings	Driveline is sized right for the intended cutting capacity. Slip-clutches will slip under load to minimize twist damage to driveline profiles.
Grease zerks on end caps of driveline	Intermediate and wing driveline cross journals are easier to grease.
High blade tip speed	Allows clean cutting of material.
6" Blade overlap	Eliminates skipping during turns.
Diamond blade bar	Provides the critical strength needed for consistent, top performance.
3/16" Round stump jumper	Standard thick stump jumper material keeps damage to a minimum.
Smooth top design	Reduces accumulation of debris and is easier and faster to clean.
Tops of decks are 100% welded	Makes center decks and wing decks stronger.
1/4" Sidewall thickness	Increased thickness reduces damage from objects being thrown into deck sidewalls.
Multiple center skid shoe locations	Run two or four skid shoes in locations under the tongue pivots or out at the wing hinges.
Beveled skid shoes on wings	Reduces gouging the ground when turning.
LED signal lights	LED lights are bright, long lasting, and resist vibration, unlike incandescent lights.
Hinged wing sections	Allows cutter to follow terrain. Ideal for rough ground where hillsides, ditches, and hollows can cause uneven cutting.
1" Solid hinge rods	Larger diameter hinge rod provides greater strength in the hinge area.
Wing transport lock pins	Transport lock pins will hold wings in folded position in the event of hydraulic loss.
Enclosed dual 1" leveling rods	Cutter pulls equally on the rear axle while traveling over rough terrain.
5-Bolt hubs	5-Bolt hubs makes the wheel assembly more durable and longer lasting.
Drain holes in wheel rims	Allows water to drain from wheels mounted on folded-up wings. Helps prevent paint deterioration and rusting to the wheel rims.
Spring cushioned center-axle	Protects unit from bumps and ground shock.
Optional spring cushioned wing-axes	Further improves ride over a multitude of terrains.
Replaceable individual wheel spindles	Spindles can be replaced when damaged without replacing entire axle assembly.
Wheel options	Laminated tires: Eliminates flats. Air-filled tires: Give better cushion while transporting. Foam-filled tires: Give better cushion while transporting and can't go flat.
LP Performance hitch option	Great for uneven terrain, reduces drawbar wear. Hitch pivots freely up and down and pivots about the tractor drawbar up to 12 degrees in both left and right directions.
Bar-tite hitch option	Ideal for extreme conditions. Clamps tight to drawbar eliminating drawbar wear.



RC(M)4715 & RCG(M)4715 Models

Features	Benefits
Maintenance free tongue & axle pivots	Self lubricating journal bearings make for less maintenance.
Color coded hydraulic hose handles	Easy hose identification & sturdy handle to easily connect & disconnect from tractor.
4 lip, metal backed wheel hub seal with purging capabilities	Seals make it harder for water & debris to enter the hub and grease to leave the hub. Metal backing prevents sticks and twine from destroying the seal lips.
Greasable cast steel, continuous hinges	Cast steel hinges make a strong connection & are easy to lubricate.
Galvanized decks on RCG models	Durable rust protection for harsh conditions.
Center axle options	<p>Single suspension center axle: Spring cushion at the cylinder for cushion with least amount of moving parts</p> <p>Independent suspension center axle: Offers additional suspension support per wheel axle.</p> <p>Walking tandem center axle: Designed for versatility over a multitude of terrains.</p> <p>Parallel pivot center axis: provides unmatched ground contact for hill-like terrains.</p>
Wing axle option	<p>Solid wing axles: One piece wing axles that get support from cylinder spring cushion on center axle.</p> <p>Independent suspension wing axles: Offers additional suspension support on each wing axle.</p>
Dual-acting fold cylinders (optional)	Allows for a narrow transport width of 7'3" (2.21 m).
Stroke control flip spacers	Easily change cut height with a flip of a spacer.
SMV Mounting Socket (Standard)	SMV mounting socket receives most SMV signs equipped with a mounting blade for ease of attachment and removal when transporting on a truck or trailer.
SMV Sign (Accessory)	SMV sign is offered as an accessory when the tractor's SMV sign and mounting blade does not fit the cutter's standard SMV mounting socket.



Troubleshooting Chart

Problem	Cause	Solution
Oil seal leaking	Gearbox overfilled	Drain oil level with fill hole or to full mark on dipstick.
	Seals damaged	Replace seals.
	Grass or wire wrapped on shaft in seal area	Clean off wrapped material and check seal areas daily.
Driveline yoke or cross failing	Clutch is froze	Slip clutches per instructions under "Lubrication Points" on page 54.
	Shock load	Avoid hitting solid objects.
	Needs lubrication	Lubricate every 8 hours.
Slip Clutches slip even with a light load	Scalping the ground	Raise cutting height.
	Clutch is not properly adjusted	Adjust clutch per instructions under "Lubrication Points" on page 54.
	Clutch plates are worn out	Replace clutch plates.
	Foreign object caught between clutch plates	Remove foreign object.
Bent driveline shaft (Note: Shaft should be repaired or replaced if bent)	Contacting frame	Reduce lift height in transport position.
	Contacting drawbar	Reposition drawbar.
	Bottoming out	Shorten driveline shaft.
	Binding up	Not lubricating enough.
Driveline shaft telescoping tube failing	Shock load	Avoid hitting solid objects.
Driveline shaft telescoping tube wearing	Needs lubrication	Lubricate every 8 hours of operation.
Blades lock-up	Blades locked together (overlapped) when wings were raised to transport position	Use pry bar or other tool to separate cutting blades before lowering wings.
	Tractor has instant on power take-off	Engage power take-off at low rpm and then slowly increase engine speed to full power take-off speed. See "Engage Blades" on page 37.
	Tractor has Instant off power take-off	Disengage blades at low rpm or change to a driveline with overrunning clutch.
Blades wearing excessively	Cutting on sandy ground	Raise cutting height.
	Contacting ground frequently	Raise cutting height.
Blades coming loose	Blades not tightened properly	Tighten blade hardware, refer to "Cutter Blades" on page 47.
	Over speeding power take-off	Operate cutter at proper power take-off speed.
Blades breaking	Hitting solid objects	Avoid hitting solid objects.
Loose blade carrier	Blade carrier hardware not tight	Tighten shaft nut to specified torque.
	Running loose in the past	Replace gearbox bearings and / or shaft.
Blade carrier bent	Hitting solid objects	Avoid hitting solid objects.
Excessive side skid wear	Soil abrasive	Adjust cutter height.
	Cutting too low	Raise cutting height.
Excessive vibration	Hitting solid objects	Inspect area before cutting. Do not hit solid objects.
	Driveline bent	Replace driveline or distribution shaft.
	Blade carrier bent	Replace blade carrier.
	Blade broken	Replace blade.
	Blade will not swing	Inspect and unlock blades.
	High torque start-up or hitting solid objects.	Disassemble and inspect driveline for incorrectly located needles or damaged bearing cap.
	Blades have unequal weight	Replace each pair of blades on affected carrier.
Wing cylinder movement too slow	Orifice is plugged	Remove elbow fitting and unplug orifice.



Torque Values Chart for Common Bolt Sizes													
Bolt Size (inches)	Bolt Head Identification						Bolt Size (Metric)	Bolt Head Identification					
	 Grade 2		 Grade 5		 Grade 8			 Class 5.8		 Class 8.8		 Class 10.9	
in-tpi ¹	N · m ²	ft-lb ³	N · m	ft-lb	N · m	ft-lb	mm x pitch ⁴	N · m	ft-lb	N · m	ft-lb	N · m	ft-lb
1/4" - 20	7.4	5.6	11	8	16	12	M 5 X 0.8	4	3	6	5	9	7
1/4" - 28	8.5	6	13	10	18	14	M 6 X 1	7	5	11	8	15	11
5/16" - 18	15	11	24	17	33	25	M 8 X 1.25	17	12	26	19	36	27
5/16" - 24	17	13	26	19	37	27	M 8 X 1	18	13	28	21	39	29
3/8" - 16	27	20	42	31	59	44	M10 X 1.5	33	24	52	39	72	53
3/8" - 24	31	22	47	35	67	49	M10 X 0.75	39	29	61	45	85	62
7/16" - 14	43	32	67	49	95	70	M12 X 1.75	58	42	91	67	125	93
7/16" - 20	49	36	75	55	105	78	M12 X 1.5	60	44	95	70	130	97
1/2" - 13	66	49	105	76	145	105	M12 X 1	90	66	105	77	145	105
1/2" - 20	75	55	115	85	165	120	M14 X 2	92	68	145	105	200	150
9/16" - 12	95	70	150	110	210	155	M14 X 1.5	99	73	155	115	215	160
9/16" - 18	105	79	165	120	235	170	M16 X 2	145	105	225	165	315	230
5/8" - 11	130	97	205	150	285	210	M16 X 1.5	155	115	240	180	335	245
5/8" - 18	150	110	230	170	325	240	M18 X 2.5	195	145	310	230	405	300
3/4" - 10	235	170	360	265	510	375	M18 X 1.5	220	165	350	260	485	355
3/4" - 16	260	190	405	295	570	420	M20 X 2.5	280	205	440	325	610	450
7/8" - 9	225	165	585	430	820	605	M20 X 1.5	310	230	650	480	900	665
7/8" - 14	250	185	640	475	905	670	M24 X 3	480	355	760	560	1050	780
1" - 8	340	250	875	645	1230	910	M24 X 2	525	390	830	610	1150	845
1" - 12	370	275	955	705	1350	995	M30 X 3.5	960	705	1510	1120	2100	1550
1-1/8" - 7	480	355	1080	795	1750	1290	M30 X 2	1060	785	1680	1240	2320	1710
1-1/8" - 12	540	395	1210	890	1960	1440	M36 X 3.5	1730	1270	2650	1950	3660	2700
1-1/4" - 7	680	500	1520	1120	2460	1820	M36 X 2	1880	1380	2960	2190	4100	3220
1-1/4" - 12	750	555	1680	1240	2730	2010	¹ in-tpi = nominal thread diameter in inches-threads per inch ² N · m = newton-meters ³ ft-lb= foot pounds ⁴ mm x pitch = nominal thread diameter in millimeters x thread pitch						
1-3/8" - 6	890	655	1990	1470	3230	2380							
1-3/8" - 12	1010	745	2270	1670	3680	2710							
1-1/2" - 6	1180	870	2640	1950	4290	3160							
1-1/2" - 12	1330	980	2970	2190	4820	3560							

Torque tolerance + 0%, -15% of torquing values. Unless otherwise specified use torque values listed above.
 All locknuts or lubricated fasteners: Use 75% of torque value. (i.e. 1/2"-13 GR5 = 76 ft-lb; 75% of 76 or .75 x 76 = 57 ft-lb)

Tire Inflation Chart	
Tire Size	Inflation PSI
25.5" and 29" tire	40 PSI (276 kPa)

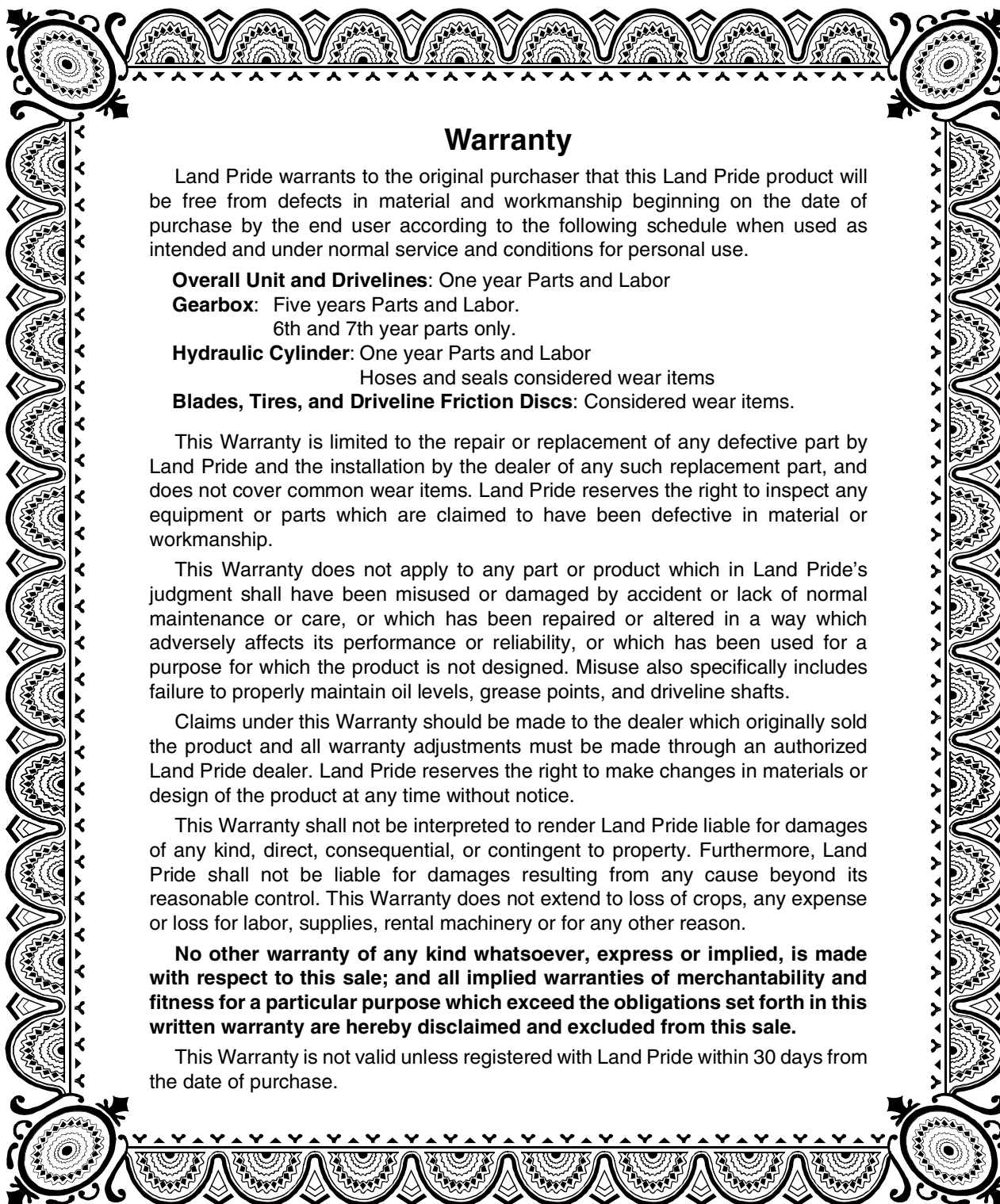

Warranty

Land Pride warrants to the original purchaser that this Land Pride product will be free from defects in material and workmanship beginning on the date of purchase by the end user according to the following schedule when used as intended and under normal service and conditions for personal use.

Overall Unit and Drivelines: One year Parts and Labor

Gearbox: Five years Parts and Labor.
6th and 7th year parts only.

Hydraulic Cylinder: One year Parts and Labor
Hoses and seals considered wear items

Blades, Tires, and Driveline Friction Discs: Considered wear items.

This Warranty is limited to the repair or replacement of any defective part by Land Pride and the installation by the dealer of any such replacement part, and does not cover common wear items. Land Pride reserves the right to inspect any equipment or parts which are claimed to have been defective in material or workmanship.

This Warranty does not apply to any part or product which in Land Pride's judgment shall have been misused or damaged by accident or lack of normal maintenance or care, or which has been repaired or altered in a way which adversely affects its performance or reliability, or which has been used for a purpose for which the product is not designed. Misuse also specifically includes failure to properly maintain oil levels, grease points, and driveline shafts.

Claims under this Warranty should be made to the dealer which originally sold the product and all warranty adjustments must be made through an authorized Land Pride dealer. Land Pride reserves the right to make changes in materials or design of the product at any time without notice.

This Warranty shall not be interpreted to render Land Pride liable for damages of any kind, direct, consequential, or contingent to property. Furthermore, Land Pride shall not be liable for damages resulting from any cause beyond its reasonable control. This Warranty does not extend to loss of crops, any expense or loss for labor, supplies, rental machinery or for any other reason.

No other warranty of any kind whatsoever, express or implied, is made with respect to this sale; and all implied warranties of merchantability and fitness for a particular purpose which exceed the obligations set forth in this written warranty are hereby disclaimed and excluded from this sale.

This Warranty is not valid unless registered with Land Pride within 30 days from the date of purchase.

IMPORTANT: The Online Warranty Registration should be completed by the dealer at the time of purchase. This information is necessary to provide you with quality customer service.

Model Number _____

Serial Number _____



Section 10: Warranty

This page is left blank intentionally.



Corporate Office: P.O. Box 5060
Salina, Kansas 67402-5060 USA
www.landpride.com
