

## RC5715 &amp; RCM5715 Models

Specifications & Capacities	
Engine horsepower range	60 - 250 hp (44.7 - 186.4 kW)
Gearbox horsepower	540 rpm or 1000 rpm 250 hp (186 kW) Divider and 225 hp (168 kW) Center & Wings
Gearbox lubrication	Gear Lube 80-90W EP
Gearbox oil capacity	Splitter: 5.5 pints (2.6 L); Center deck & Wings: 12.4 pints (5.87 L)
Cutting capacity	5" (13 cm)
Machine weight	5,880 lbs (2667 kg) - Weight includes base unit, six 21" laminated tires, HD single suspension center & wing axles, 540 CV Cat. 4 main driveline package, front & rear single chain guards, single acting fold cylinders, constant level clevis hitch, and forged blade bar with bolt-on dishpan blade carriers.
Tongue weight	2,226 lbs (1010 kg) with wings down.
Blade tip speed	At 540 rpm At 1000 rpm
	Center Blades & Wing Blades = 16,400 FPM (83 mps) Center Blades = 16,400 FPM (83 mps) & Wing Blades = 16,000 FPM (81.3 mps)
A-frame tongue	5" x 3" (12.7 cm x 7.6 cm) rectangular tubing.
Hitch types	Constant Level Swivel Clevis Hitch, LP Performance Hitch™, Self Leveling Bar-Tite Hitch, Ball Hitch, or Constant Level Pintle Hitch.
LP Performance Hitch & Bar-Tite hitch pivot shaft diameter	2 1/4" (5.7 cm)
Hitch jack	Standard 7,000 lbs. (3175.1 kg)
Signal lights	LED
Seven pin connector	SAE J560 pin configuration
Cutting width	15'-0" (4.57 m)
Overall width	16'-0" (4.88 m)
Transport width with 21" tires	10'-3" (3.12 m) - Single-acting fold option, 7'-3" (2.21 m) - Dual-acting fold option.
Overall length	16'-3" (4.95 m) - With center deck raised fully up.
Deck height	12" (30.5 cm)
Cutting height	1-1/2" - 16" (3.8 cm - 40.6 cm) - Varies by tire option.
Lift hydraulics	3 1/2" x 8" hydraulic cylinder, hoses, fittings & flip-over spacers.
Wing flex while operating	Max. 20° down, Can float up as needed as long as the wheel(s) are still on the ground.
Wing hydraulics	3" x 12" hydraulic cylinders, hoses & fittings.
Wing transport protection	Wing Transport Lock Pin.
Deck material thickness	Top deck plate = 10 Gauge (3.4 mm); Bottom deck plate = 3/16" (5 mm)
Side skirt construction	Removable/replaceable 1/4" (6 mm) steel.
Deck Armor™ (Optional)	5/16" (8 mm) Steel plate
Wing deck skid shoes	Each wing has one leading hardened beveled skid shoe and one trailing standard beveled skid shoe. Both are reversible and replaceable.
Center deck skid shoes	Two replaceable beveled skid shoes and multiple mounting locations.
Blades - 6 (2 per carrier)	1/2" x 4" (1.3 cm - 10.2 cm) Heat-treated, free-swinging alloy steel with uplift.
Blade overlap	6" (15.2 cm)
Blade bolt	Keyed with hardened flat washer & locknut.
Stump jumper / blade holder options	Forged blade bar without the dish pan. Thick 3/16" (5 mm) round dish shaped pan, reinforced with the forged blade bar. Thick 3/16" (5 mm) round dish shaped pan, reinforced with the heavy duty blade plate. Stacked blade shredder Kit without the dish pan.
Front & rear guards	Optional single row chain or dual row chain.
Input driveline 540 & 1000 rpm	Cat. 6 with constant velocity u-joint with or without over-running clutch.
Intermediate driveline	Standard - Category 5 with slip-clutch.
Wing drivelines	Standard - Category 4 with slip-clutch or Category 5 with slip-clutch.
Number of wheels	6 - Wheel option: Four on transport axle and one on each wing axle. 8 - Wheel option: Four on transport axle and two on each wing axle.

**RC5715 & RCM5715 Models**

Specifications & Capacities Continued	
<b>Wheel options</b>	21" (53.3 cm) or 26" (66 cm) Laminated tires. 24" (61 cm) Used aircraft, foam filled tires. 25.5" (64.8 cm) 20 ply tires, foam filled or pneumatic. 29" (73.7 cm) Used aircraft tires.
<b>Transport axle</b>	Many configurations to choose from.
<b>Hubs</b>	Cast iron five-bolt hubs with tapered roller bearings and 1 3/4" (4.4 cm) shafts.
<b>SMV Sign (Accessory)</b>	SMV decal on galvanized steel back sign and plated or galvanized blade mount.

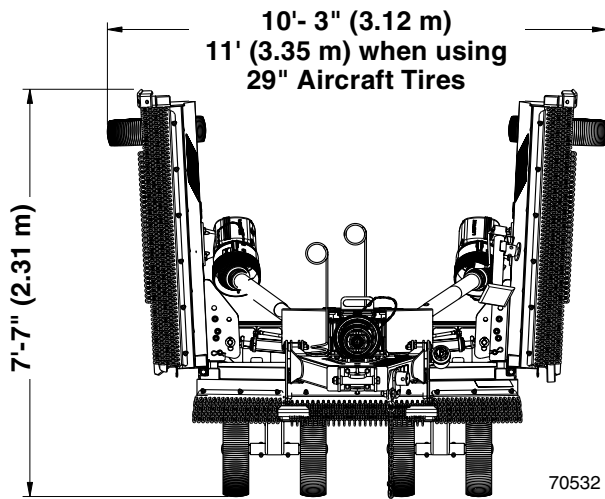

**Transport Width  
With Single Action Fold Option**

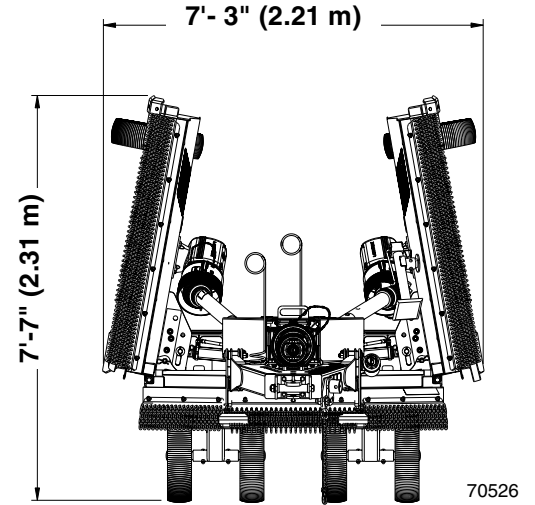

**Narrow Transport Width  
With Dual Action Fold Option**

