

Skid Cutter

AP-SC7072

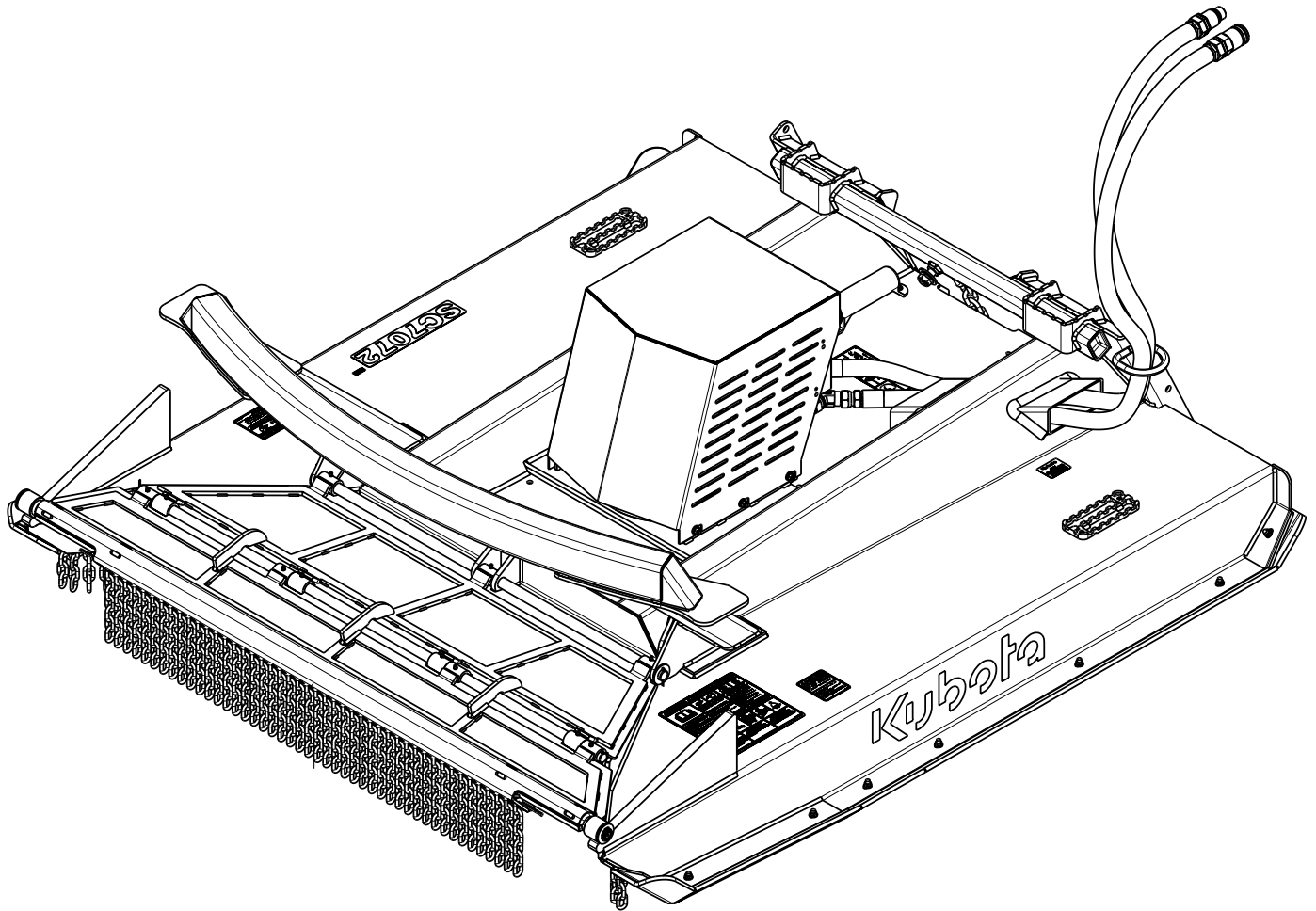

70395

326-974MK Operator's Manual

Kubota®



Read the Operator's Manual entirely. When you see this symbol, the subsequent instructions and warnings are serious - follow without exception. Your life and the lives of others depend on it!

Cover photo may show optional equipment not supplied with standard unit.

For an Operator's Manual and Decal Kit in French Language, please see your Kubota dealer.

Machine Identification

Record your machine details in the log below. If you replace this manual, be sure to transfer this information to the new manual.

If you, or the dealer, have added Options not originally ordered with the machine, or removed Options that were originally ordered, the weights and measurements are no longer accurate for your machine. Update the record by adding the machine weight and measurements provided in the Specifications & Capacities Section of this manual with the Option(s) weight and measurements.

Model Number	
Serial Number	
Machine Height	
Machine Length	
Machine Width	
Machine Weight	
Delivery Date	
First Operation	
Accessories	<hr/> <hr/> <hr/>

Dealer Contact Information

Name: _____

Street: _____

City/State: _____

Telephone: _____

Email: _____

 California Proposition 65 WARNING: Cancer and reproductive harm - www.P65Warnings.ca.gov

Important Safety Information	1	Section 5: Maintenance & Lubrication	24
Safety at All Times	1	Maintenance	24
Look for the Safety Alert Symbol	1	Hydraulic Maintenance	24
Safety Labels	6	Cutter Blade Maintenance	24
Introduction	8	Carbide Teeth Maintenance	25
Application	8	Skid Shoe Maintenance	26
Using This Manual	8	Long-Term Storage	27
Terminology	8	Lubrication Points	28
Owner Assistance	8	Bi-Fold Door	28
Serial Number	8	In Line Bearing Housing	28
Further Assistance	8	Section 6: Specifications & Capacities	29
Section 1: Assembly & Set-up	9	Section 7: Features & Benefits	31
Skid Steer Requirements	9	Section 8: Troubleshooting	32
Dealer Preparations	9	Section 9: Torque Values Chart	33
Uncrating	9	Section 10: Legal Disclaimer & Warranty	34
Torque Requirements	9		
Hitch Hook-Up	10		
Height Adjustment Safety Chain	11		
Hydraulic Hose Hook-Up	12		
Protective Door Assembly (option)	12		
Case Drain Assembly (Optional)	13		
Pressure Gauge Assembly (Optional)	14		
Section 2: Adjustments	15		
Equipment Clearances	15		
Section 3: Operating Procedures	16		
Operating Checklist	16		
Safety Information	16		
Skid Steer Shutdown Procedures	17		
Transporting	17		
Cutting Instructions	18		
General Operating Instructions	20		
Skid Steer Operating Instructions	20		
Skid Cutter Operating Instructions	20		
Section 4: Options & Accessories	22		
Pressure Gauge Bundle (Option)	22		
Case Drain Bundle (Option)	22		
Narrow Skid Shoes (Accessory)	22		
Polycarbonate Protective Door (Option)	23		

© Copyright 2021 All rights Reserved

Kubota provides this publication "as is" without warranty of any kind, either expressed or implied. While every precaution has been taken in the preparation of this manual, Kubota assumes no responsibility for errors or omissions. Neither is any liability assumed for damages resulting from the use of the information contained herein. Kubota reserves the right to revise and improve its products as it sees fit. This publication describes the state of this product at the time of its publication, and may not reflect the product in the future.

Kubota is a registered trademark.

All other brands and product names are trademarks or registered trademarks of their respective holders.

Printed in the United States of America.

See previous page for Table of Contents.



Parts Manual QR Locator

The QR (Quick Reference) code on the left will take you to the Parts Manual for this equipment. Download the appropriate App on your smart phone, open the App, point your phone on the QR code and take a picture.



Dealer QR Locator

The QR code to the left will link you to available dealers for Kubota products. Refer to Parts Manual QR Locator on this page for detailed instructions.

Listed below are common practices that may or may not be applicable to the products described in this manual.

Safety at All Times

Careful operation is your best assurance against an accident.

All operators, no matter how much experience they may have, should carefully read this manual and other related manuals, or have the manuals read to them, before operating the power machine and this attachment.

- ▲ Thoroughly read and understand the “Safety Label” section. Read all instructions noted on them.
- ▲ Do not operate the equipment while under the influence of drugs or alcohol as they impair the ability to safely and properly operate the equipment.
- ▲ Operator should be familiar with all functions of the skid steer and attachment and be able to handle emergencies quickly.
- ▲ Make sure all guards and shields appropriate for the operation are in place and secured before operating the attachment.
- ▲ Keep all bystanders away from equipment and work area.
- ▲ Start skid steer from the driver’s seat with steering levers and hydraulic controls in neutral.
- ▲ Operate skid steer and controls from the driver’s seat only.
- ▲ Never dismount from a moving skid steer or leave the skid steer unattended with the engine running.
- ▲ Do not allow anyone to stand between the attachment and skid steer while hooking-up.
- ▲ Keep hands, feet, and clothing away from power-driven parts.
- ▲ While transporting and operating equipment, watch out for objects overhead and along side such as fences, trees, buildings, wires, etc.
- ▲ Store attachment in an area where children normally do not play. When needed, secure attachment against falling with support blocks.



Look for the Safety Alert Symbol

The SAFETY ALERT SYMBOL indicates there is a potential hazard to personal safety and extra precaution must be taken. When you see this symbol, be alert and carefully read the message that follows it. Hazard control, and accident prevention are dependent upon the awareness, concern, prudence, and proper training of personnel involved in the operation, transport, maintenance, and storage of equipment.

Be Aware of Signal Words

A signal word designates a degree or level of hazard seriousness. They are:

- ▲ **DANGER:** Indicates a hazardous situation that, if not avoided, will result in death or serious injury.
- ▲ **WARNING:** Indicates a hazardous situation that, if not avoided, could result in death or serious injury.
- ▲ **CAUTION:** Indicates a hazardous situation that, if not avoided, may result in minor or moderate injury.

Be Aware of Special Notices

Special notices are intended to point out important and helpful information that should be followed. They are usually placed inside a box. They are:

- ▲ **IMPORTANT:** Indicates that equipment or property damage could result if instructions are not followed.
- ▲ **NOTE:** Indicates supplementary explanations that will be helpful when using the equipment.

Safety Precautions for Children

Tragedy can occur if the operator is not alert to the presence of children. Children generally are attracted to attachments and their work.

- ▲ Never assume children will remain where you last saw them.
- ▲ Keep children out of the work area and under the watchful eye of a responsible adult.
- ▲ Be alert and shut the attachment and skid steer/track loader down if children enter the work area.
- ▲ Never carry children on the power machine or attachment. There is not a safe place for them to ride. They may fall off and be run over or interfere with the control of the power machine.
- ▲ Never allow children to operate the power machine, even under adult supervision.
- ▲ Never allow children to play on the power machine or attachment.
- ▲ Use extra caution when backing up. Before the power machine starts to move, look down and behind to make sure the area is clear.

Skid Steer Shutdown And Storage

- ▲ Reduce engine speed and shut-off all power to the attachment.
- ▲ Park on solid, level ground and lower attachment until it is flat on the ground or on non-concrete support blocks.
- ▲ Turn off engine. Do not remove ignition key at this time.
- ▲ Turn ignition key to the “RUN” position. Relieve all hydraulic pressure by moving both joysticks.
- ▲ Turn ignition key to Off and remove to prevent unauthorized starting.
- ▲ If included, raise seat bar and move controls until both lock.
- ▲ Wait for all components to stop before leaving operator’s seat.
- ▲ Use steps, grab-handles and anti-slip surfaces when stepping on and off the skid steer.

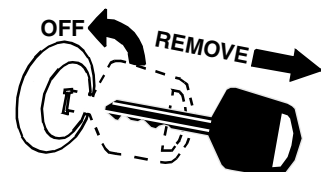

Listed below are common practices that may or may not be applicable to the products described in this manual.

Dig Safe - Avoid Underground Utilities

- ▲ **USA: Call 811**
CAN: digsafecanada.ca
Always contact your local utility companies (electrical, telephone, gas, water, sewer, and others) before digging so that they may mark the location of any underground services in the area.
- ▲ Be sure to ask how close you can work to the marks they positioned.



Transport Safely

- ▲ Comply with federal, state, and local laws.
- ▲ Use towing vehicle and trailer of adequate size and capacity. Secure equipment towed on a trailer with chocks, tie downs, and chains.
- ▲ Sudden braking can cause a towed trailer to swerve unexpectedly. Reduce speed if towed trailer is not equipped with brakes.
- ▲ Avoid contact with any overhead utility lines or electrically charged conductors.
- ▲ Always drive with load on end of loader arms low to the ground.
- ▲ Always drive straight up and down steep inclines with heavy end of skid steer on the "uphill" side.
- ▲ Engage park brake when stopped on an incline.
- ▲ Maximum transport speed for an attached equipment is 20 mph (32 km/h). **DO NOT EXCEED.** Never travel at a speed which does not allow adequate control of steering and stopping. Some rough terrains require a slower speed.
- ▲ As a guideline, use the following maximum speed weight ratios for attached equipment:
 - 20 mph (32 km/h)** when weight of attached equipment is less than or equal to the weight of machine towing the equipment.
 - 10 mph (16 km/h)** when weight of attached equipment exceeds weight of machine towing equipment but not more than double the weight.
- ▲ **IMPORTANT:** Do not tow a load that is more than double the weight of the vehicle towing the load.

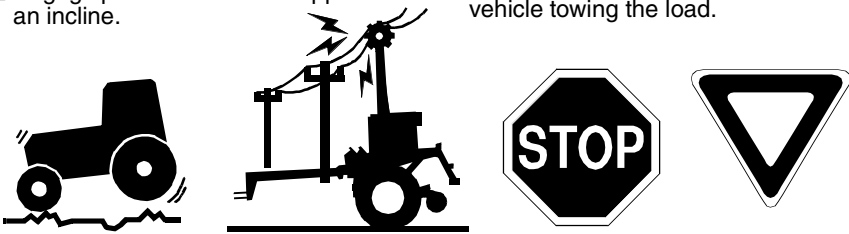

Tire Safety

- ▲ Tire changing can be dangerous and must be performed by trained personnel using the correct tools and equipment.
- ▲ Always properly match the wheel size to the properly sized tire.
- ▲ Always maintain correct tire pressure. Do not inflate tires above recommended pressures shown in the Operator's Manual.
- ▲ When inflating tires, use a clip-on chuck and extension hose long enough to allow you to stand to one side and NOT in front of or over the tire assembly. Use a safety cage if available.
- ▲ Securely support the attachment when changing a wheel.
- ▲ When removing and installing wheels, use wheel handling equipment adequate for the weight involved.
- ▲ Make sure wheel bolts have been tightened to the specified torque.



Practice Safe Maintenance

- ▲ Understand procedure before doing work. Refer to the Operator's Manual for additional information.
- ▲ Work on a level surface in a clean dry area that is well-lit.
- ▲ Lower attachment to the ground and follow all shutdown procedures before leaving the operator's seat to perform maintenance.
- ▲ Do not work under any hydraulically supported equipment. It can settle, suddenly leak down, or be lowered accidentally. If it is necessary to work under the equipment, securely support it with stands or suitable blocking beforehand.
- ▲ Use properly grounded electrical outlets and tools.
- ▲ Use correct tools and equipment for the job that are in good condition.
- ▲ Allow equipment to cool before working on it.
- ▲ Disconnect battery ground cable (-) before servicing or adjusting electrical systems or before welding on equipment.
- ▲ Inspect all parts. Make certain that parts are in good condition & installed properly.
- ▲ Replace parts on this attachment with genuine Kubota parts only. Do not alter this attachment in a way which will adversely affect its performance.
- ▲ Do not grease or oil attachment while it is in operation.
- ▲ Remove buildup of grease, oil, or debris.
- ▲ Always make sure any material and waste products from the repair and maintenance of the attachment are properly collected and disposed.
- ▲ Remove all tools and unused parts from the equipment before operation.



These are common practices that may or may not be applicable to the products described in this manual.

Prepare for Emergencies

- ▲ Be prepared if a fire starts.
- ▲ Keep a first aid kit and fire extinguisher handy.
- ▲ Keep emergency numbers for doctor, ambulance, hospital, and fire department near phone.

Wear Personal Protective Equipment (PPE)

- ▲ Wear protective clothing and equipment appropriate for the job such as safety shoes, safety glasses, hard hat, dust mask, and ear plugs.
- ▲ Clothing should fit snug without fringes and pull strings to avoid entanglement with moving parts.
- ▲ Prolonged exposure to loud noise can cause hearing impairment or hearing loss. Wear suitable hearing protection such as earmuffs or earplugs.
- ▲ Operating a machine safely requires the operator's full attention. Avoid wearing headphones while operating equipment.

Avoid High Pressure Fluids

- ▲ Escaping fluid under pressure will penetrate the skin or eyes causing serious injury.
- ▲ Relieve all residual pressure before disconnecting hydraulic lines or performing work on the hydraulic system.
- ▲ Make sure all hydraulic fluid connections are properly tightened/torqued and all hydraulic hoses and lines are in good condition before applying pressure to the system.
- ▲ Use a piece of paper or cardboard, NOT BODY PARTS, to check for suspected leaks.
- ▲ Wear protective gloves and safety glasses or goggles when working with hydraulic systems.
- ▲ **DO NOT DELAY.** If an accident occurs, seek immediate emergency medical care or gangrene may result.

Use Safety Lights and Devices

- ▲ A slow moving power machine can create a hazard when driven on public roads. They are difficult to see, especially at night. Use the Slow Moving Vehicle (SMV) sign when on public roads.
- ▲ Flashing warning lights and turn signals are recommended whenever driving on public roads.

Use Seat Belt and ROPS

- ▲ Kubota recommends the use of a CAB or roll-over-protective-structures (ROPS) and seat belt in almost all power machines. Combination of a CAB or ROPS and seat belt will reduce the risk of serious injury or death if the power machine should be upset.
- ▲ If ROPS is in the locked-up position, fasten seat belt snugly and securely to help protect against serious injury or death from falling and machine overturn.

Keep Riders Off Machinery

- ▲ Never carry riders on skid steer or attachment.
- ▲ Riders obstruct operator's view and interfere with the control of the power machine.
- ▲ Riders can be struck by objects or thrown from the equipment.
- ▲ Never use skid steer or attachment to lift or transport riders.

Listed below are common practices that may or may not be applicable to the products described in this manual.

Avoid crystalline Silica (quartz) Dust

Because crystalline silica is a basic component of sand and granite, many activities at construction sites produce dust containing crystalline silica. Trenching, sawing, and boring of material containing crystalline silica can produce dust containing crystalline silica particles. This dust can cause serious injury to the lungs (silicosis).

There are guidelines which should be followed if crystalline silica (quartz) is present in the dust.



- ▲ Be aware of and follow OSHA (or other local, State, or Federal) guidelines for exposure to airborne crystalline silica.
- ▲ Know the work operations where exposure to crystalline silica may occur.
- ▲ Participate in air monitoring or training programs offered by the employer.
- ▲ Be aware of and use optional equipment controls such as water sprays, local exhaust ventilation, and enclosed cabs with positive pressure air conditioning if the machine has such equipment. Otherwise respirators shall be worn.
- ▲ Where respirators are required, wear a respirator approved for protection against crystalline silica containing dust. Do not alter respirator in any way. Workers who use tight-fitting respirators can not have beards/mustaches which interfere with the respirator seal to the face.
- ▲ If possible, change into disposable or washable work clothes at the work site; shower and change into clean clothing before leaving the work site.
- ▲ Do not eat, drink, use tobacco products, or apply cosmetics in areas where there is dust containing crystalline silica.
- ▲ Store food, drink, and personal belongings away from the work area.
- ▲ Wash hands and face before eating, drinking, smoking, or applying cosmetics after leaving the exposure area.

Handle Chemicals Properly

- ▲ Protective clothing should be worn.
- ▲ Handle all chemicals with care.
- ▲ Follow instructions on container label.
- ▲ Agricultural chemicals can be dangerous. Improper use can seriously injure persons, animals, plants, soil, and property.
- ▲ Inhaling smoke from any type of chemical fire can be a serious health hazard.
- ▲ Store or dispose of unused chemicals as specified by the chemical manufacturer.



This page left blank intentionally.

Safety Labels

Your Skid Cutter comes equipped with all safety labels in place. They are designed to help you safely operate your attachment. Read and follow their directions.

1. Keep all safety labels clean and legible.
2. Refer to this section for proper label placement. Replace all damaged or missing labels. Order new labels from your nearest Kubota dealer. To find your nearest dealer, visit our dealer locator at www.landpride.com.
3. Some new equipment installed during repair requires safety labels to be affixed to the replaced component as

specified by Kubota. When ordering new components make sure the correct safety labels are included in the request.

4. Refer to this section for proper label placement. To install new labels:
 - a. Clean surface area where label is to be placed.
 - b. Spray soapy water onto the cleaned area.
 - c. Peel backing from label and press label firmly onto the surface.
 - d. Squeeze out air bubbles with edge of a credit card or with a similar type of straight edge.

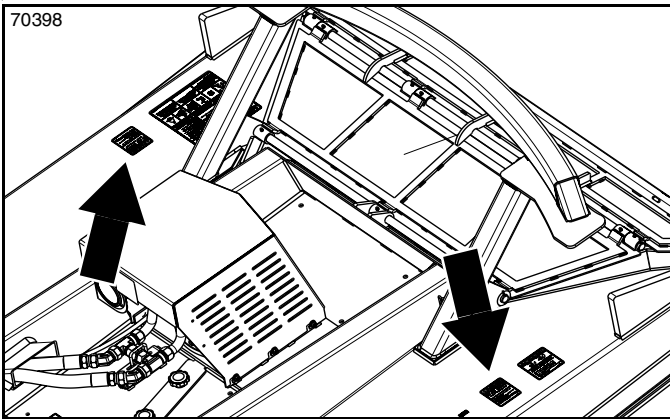

858-843C
Danger: Do Not Operate

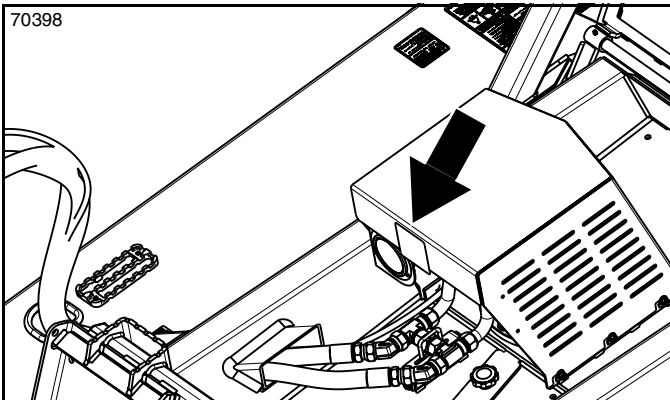

844-317C
Danger: Rotating Blades

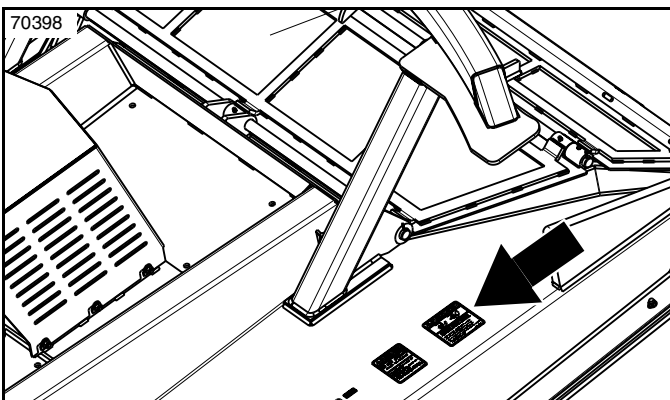

818-555C
Danger: Rotating Blade Hazard

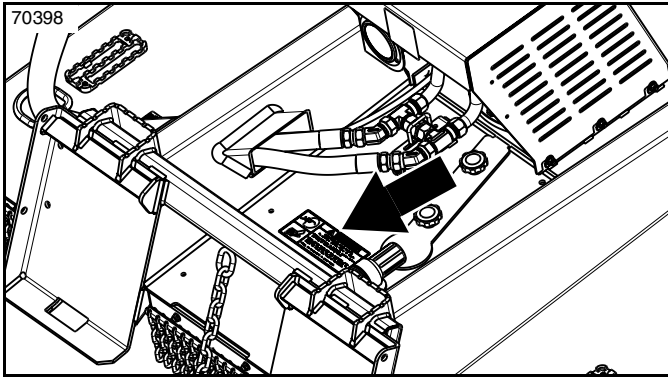

		⚠ WARNING
		<p>HIGH-PRESSURE FLUID HAZARD To prevent serious injury or death</p> <ul style="list-style-type: none"> •Relieve pressure on hydraulic system before servicing or disconnecting hoses. •Wear proper hand and eye protection when searching for leaks. Do not use fingers to check for leaks; use wood or cardboard. •Keep all components in good repair.

818-831C

Warning: High Pressure

⚠ WARNING	⚠ WARNING	⚠ DANGER	
	<p>HIGH PRESSURE FLUID HAZARD To prevent Serious Injury or Death:</p> <ul style="list-style-type: none"> •Relieve pressure on system before repairing, adjusting, or disconnecting. •Wear proper hand and eye protection when searching for leaks. Use wood or cardboard instead of hands. •Keep all components in good repair. 		<p>THROWN OBJECT AND ROTATING BLADE HAZARD To prevent serious injury or death:</p> <ul style="list-style-type: none"> •Do not operate unless all guards are installed and in good condition. •Inspect and clear debris from mowing area prior to mowing. •Do not operate with bystanders in or around mowing area. •Do not place hands or feet under deck when operating or when engine is running. •Do NOT dismount until blades come to a complete stop.
<p>To prevent serious injury or death:</p> <ul style="list-style-type: none"> •Do not operate or work on this machine without reading and understanding the Operator's Manual. •Avoid unsafe operation or maintenance. •Transport with clean reflectors, SMV, and lights as required by federal, state, and local laws. •If manual is lost, contact your nearest dealer for a new manual. 			
⚠ WARNING	⚠ WARNING	⚠ WARNING	
<p>CRUSHING HAZARD Before performing maintenance on machine and to prevent serious injury or death:</p> <ul style="list-style-type: none"> •Read and understand operator's manual. •Stop engine, set brake, and wait for all moving parts to stop before dismounting. •Support cutter securely before working beneath. 	<p>RUN OVER HAZARD To prevent serious injury or death:</p> <ul style="list-style-type: none"> •Always use seat belt when operating. •Never allow riders on propelling machine or attachment. 	<p>ROLLOVER HAZARD To prevent serious injury or death:</p> <ul style="list-style-type: none"> •Always use seat belt when operating. •Only operate on propelling machine with a rollover protective structure (ROPS). •Use caution when mowing along inclines. 	

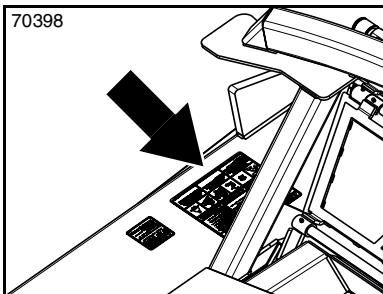

844-191C

Safety Combo

Warning: Read Manual - Observe Safety Messages

Warning: High Pressure Fluid Hazard

Danger: Thrown Object and Rotating Blade Hazard

Warning: Crushing Hazard

Warning: Run Over Hazard

Warning: Rollover Hazard

Introduction

Kubota welcomes you to the growing family of new product owners. This Skid Cutter has been designed with care and built by skilled workers using quality materials. Proper assembly, maintenance, and safe operating practices will help you get years of satisfactory use from this product.

Application

SC7072 construction-grade Skid Cutter is designed with the commercial or high use consumer in mind. It features a rigid hitch mounting system, 1/4" (6 mm) thick deck, 4 swinging blades, and a bi-fold door on the front. The SC7072 is capable of cutting and shredding brush or trees up to 7" (18 cm) in diameter. Carbide mulching teeth mounted on the bottom of the blade carrier can be used for grinding stumps. The strong push bars on top and under the door of the SC7072 Skid Cutter allow the operator to push trees and brush over and away from the operator as they are being cut without damaging the unit. The ability to cut and mulch trees and stumps level to the ground makes this cutter ideal for clearing right-of-ways along road sides, pipelines or under electrical transmission lines with the speed and efficiency needed by today's contractors. Farmers, ranchers and land developers will also benefit from this unit when clearing pastures or new development areas. The SC7072 Skid Cutter utilizes the power, compact size, and the go anywhere ability of a SVL to access over grown areas where a tractor and rotary cutter cannot go. The wide, full-length tapered skid shoes prevent the cutter from digging in or getting hung up in the soft ground usually found under heavy brush. Use if this skid cutter is limited to standard brush cutting. Use in significantly larger or denser brush will result in excessive heat and may damage the skid cutter or the skid steer.

Using This Manual

- This Operator's Manual is designed to help familiarize you with safety, assembly, operation, adjustments, troubleshooting, and maintenance. Read this manual and follow the recommendations to help ensure safe and efficient operation.
- The information contained within this manual was current at the time of printing. Some parts may change slightly to assure you of the best performance.
- To order a new Operator's or Parts Manual, contact your authorized dealer. Manuals can also be downloaded free-of-charge, from our website at www.landpride.com.
- Store your Operator's Manual in the dry storage tube. See Figure 1 on page 8 for location of storage tube.

Terminology

"Right" or "left" as used in this manual is determined by the direction the operator faces while sitting looking forward in the operator's seat unless otherwise stated.

Owner Assistance

The dealer should complete the Online Warranty Registration at the time of purchase. This information is necessary to provide you with quality customer service.

The parts on your Skid Cutter have been specially designed by Kubota/Land Pride and should only be replaced with genuine Kubota parts. Contact a Kubota dealer if customer service or repair parts are required. Your Kubota dealer has trained personnel, repair parts, and equipment needed to service the attachment.

See "**Specifications & Capacities**" on page 29 and "**Features & Benefits**" on page 31 for additional information and performance enhancing options.

Serial Number

For quick reference and prompt service, record model and serial number on the inside cover page and again on the warranty page. Always provide model number and serial number when ordering parts and in all correspondences with your Kubota dealer. For location of your serial number plate, see Figure 1.

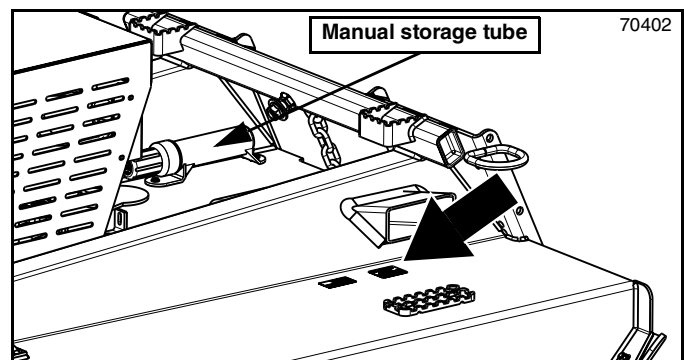

Serial Number Plate Location
Figure 1

Further Assistance

Your Kubota dealer wants you to be satisfied with your new attachment. If for any reason you do not understand any part of this manual or are not satisfied with the service received, the following actions are suggested:

1. Discuss any problems you have with your attachment with your dealership service personnel so they can address the problem.
2. If you are still not satisfied, seek out the owner or general manager of the dealership, explain the question/problem, and request assistance.
3. For further assistance write to:

**Kubota by Land Pride
Service Department**

**1525 East North Street
P.O. Box 5060
Salina, Ks. 67402-5060**

E-mail address
lp servicedept@landpride.com

Section 1: Assembly & Set-up

Skid Steer Requirements

The Skid Cutter is designed to attach to skid steer loaders and track loaders with the following minimum requirements:

- Hitch type ISO 24410
- Rated Operating Load 3500 lbs (1588 kg)
- Hydraulic Pressure Rating . . up to 3500 psi (24 MPa)
- High Volume Motor 26-43 gpm (98.4-162.8 Lpm)
- Door Polycarbonate
- Case Drain Optional
- Skid Steer Weight See warning below
- Protective Operator Door¹ Polycarbonate

Notes:

1. A polycarbonate door can be purchased from your nearest Kubota dealer. Refer to “**Polycarbonate Protective Door (Option)**” on page 23.

WARNING

To avoid serious injury or death:

- *Lightweight power machines may need weight added to the rear to maintain steering control and prevent forward tipping or side tipping caused by a heavy front load. Consult your power machine Operator’s Manual to determine proper weight requirements and maximum weight limitations.*
- *To protect the operator from thrown objects, the skid steer or track loader MUST be equipped with a polycarbonate protective door, and the operator MUST wear eye protection such as safety glasses or goggles.*
- *Consult your skid steer’s manual for operating capacity, lifting capacity, and operating specifications. Exceeding rated capacities and specifications can result in a roll-over or other serious hazard.*

Dealer Preparations

WARNING

To avoid serious injury or death:

Allow only persons to operate this attachment who have fully read and comprehended this manual, and who have been properly trained in the safe operation of this attachment. Serious injury or death can result from failure to read, understand, and follow instructions provided in this manual.

Read and understand the Operator’s Manual for this cutter. An understanding of how it works will aid in the assembly and setup of your cutter.

This Skid Cutter has been partially assembled at the factory. However, some assembly will be necessary.

It is best to go through the “**Pre-Assembly Checklist**” on this page before assembling the cutter. Speed up your assembly task and make the job safer by having all the needed parts and equipment readily at hand.

Ensure that the intended skid steer conforms to the requirements stated under the heading “**Skid Steer Requirements**” on this page.

Uncrating

WARNING

To avoid serious injury or death:

Always secure cutter with an overhead crane, fork lift, or other suitable lifting device before removing hardware bags, shipping components, bands, lag screws, or hitch pins. The cutter can suddenly fall.

1. Secure deck with an overhead crane, fork lift, or other suitable means before cutting shipping support bands and unbolting cutter from shipping crate.
2. Cut bands securing parts bags to the shipping crate.
3. Remove bolts securing hitch to the shipping crate.
4. Cut center band securing hitch to shipping crate.
5. Carefully lift cutter from crate and lower onto its skids or onto support stands capable of supporting the cutter.
6. Remove remaining components from crate. Discard crate.

Torque Requirements

See “**Torque Values Chart**” on page 33 to determine correct torque values when tightening hardware.

Pre-Assembly Checklist

✓	Check
<input type="checkbox"/>	All hardware from the factory has been installed. If a part or fastener is temporarily removed for assembly, remember where it goes. Keep parts separated.
<input type="checkbox"/>	Be sure the parts get used in the correct location. By double checking while you assemble, you will lessen the chance of using a bolt incorrectly that may be needed later. Use Parts Manual to identify location of parts you are unsure of where they are used.
<input type="checkbox"/>	All grease fittings are in place and lubricated.
<input type="checkbox"/>	Miscellaneous assembly tools: hammer, tape measure, assortment of wrenches and a level.
<input type="checkbox"/>	Have fork lift or loader along with chains and safety stands sized for the job ready for the assembly task.
<input type="checkbox"/>	Auxiliary weights (depending on skid steer size).
<input type="checkbox"/>	Have a minimum of 2 people at hand while assembling.
<input type="checkbox"/>	Safety decals are legible and undamaged.
<input type="checkbox"/>	Loose parts bag/box shipped with the Skid Cutter.

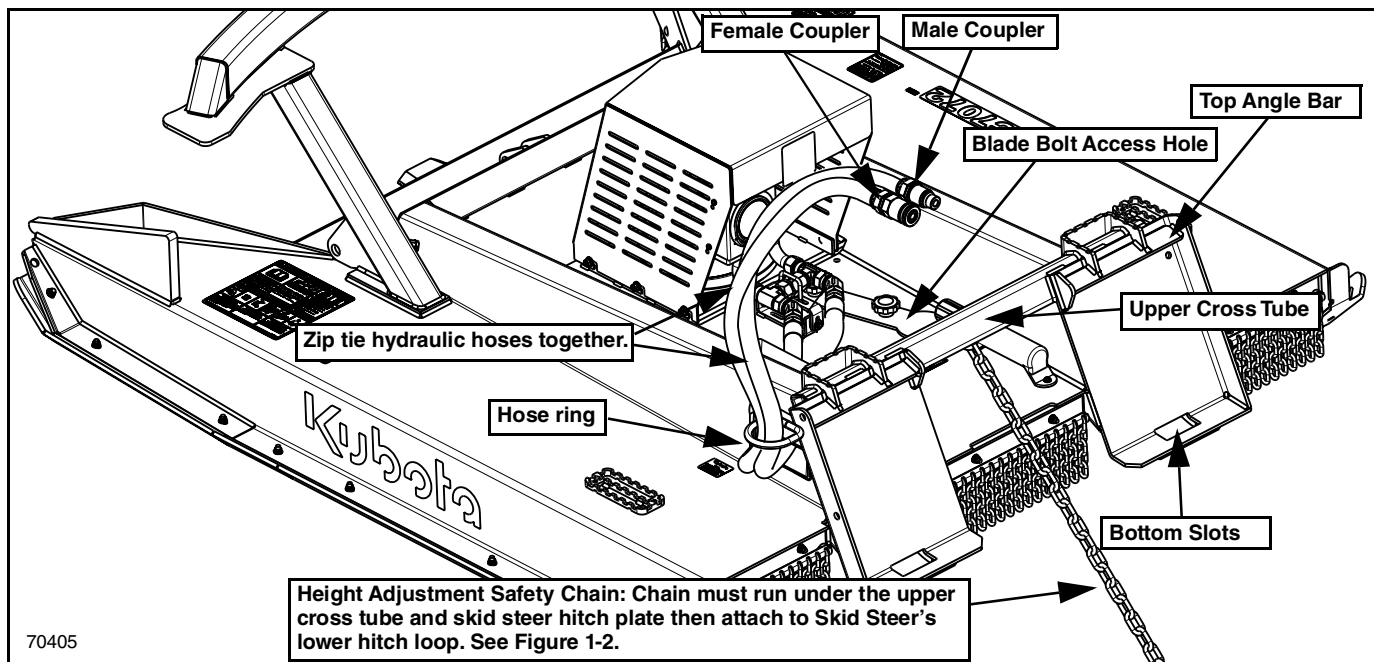

Skid Steer Hook-Up
Figure 1-1

Hitch Hook-Up

Refer to Figure 1-1:



To avoid serious injury or death:

A crushing hazard exists when hooking-up and unhooking the attachment. Do not allow anyone to stand between attachment and power machine while approaching or backing away from the attachment. Do not operate hydraulic controls while someone is near the power machine and/or attachment.

1. Make sure hydraulic hoses and height adjustment safety chain do not interfere with hitch hook-up.
2. Drive skid steer slowly to the Skid Cutter making sure the front hitch plate of the skid steer is parallel with the Skid Cutter hitch.
3. Tilt top of skid steer hitch plate slightly forward.
4. Place top of skid steer hitch plate directly under the Skid Cutter top angle bar.
5. Slowly lift skid steer hitch until it fully contacts the Skid Cutter top angle bar.
6. Slowly rotate skid steer hitch plate back.
7. Engage skid steer lock handles. Make sure the pins go through the bottom slots of the Skid Cutter's hitch and the handles lock down.

NOTE: If the skid steer is not equipped with hydraulic lock handles, the skid steer must be shut down and lock handles must be manually engaged. Refer to “**Skid Steer Shutdown Procedures**” on page 17.

Refer to Figure 1-2

8. Connect the safety chain to the skid steer. For additional information on how to adjust the safety chain, see “**Height Adjustment Safety Chain**” on page 11.

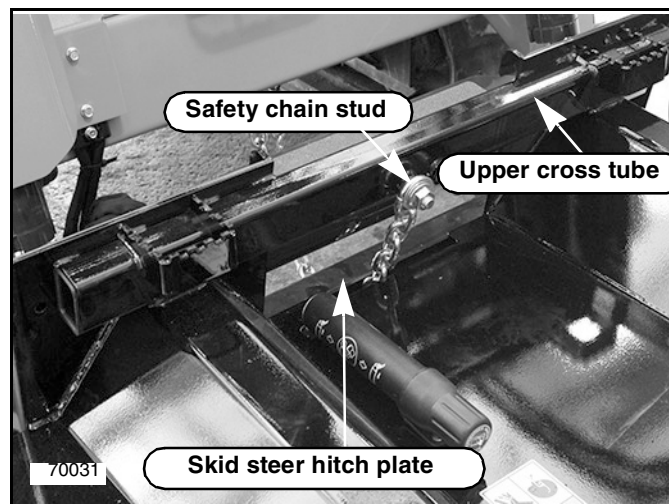

Height Adjustment Safety Chain (Kubota SVL Shown)
Figure 1-2

IMPORTANT: The safety chain must run under the upper cross tube and the skid steer hitch plate or damage can occur.

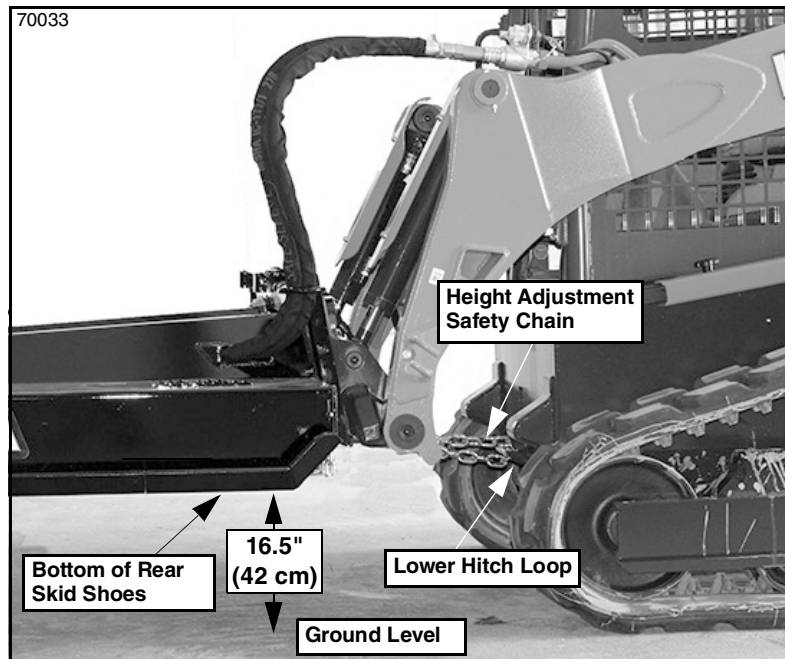

Nominal Cutting Height (SVL shown)
Figure 1-3

Height Adjustment Safety Chain

DANGER

To avoid serious injury or death:

- Do not operate cutter with skid shoes any higher than 16.5" (42 cm) off the ground. Always use height adjusting safety chain to limit cutting height. Raising cutter too high will throw debris at the operator.
- Always secure equipment with solid, non-concrete supports before working under it. Never go under equipment supported by concrete blocks or hydraulics. Concrete can break, hydraulic lines can burst, and/or hydraulic controls can be actuated even when power to hydraulics is off.

Refer to Figure 1-3:

For safety, the cutter's rear skid shoes should not be raised higher than 16 1/2" (42 cm) off the ground 18" (46 cm) maximum cutting height.

NOTE: Two people may be required to install and adjust the height adjustment safety chain.

1. Raise cutter's rear skid shoes slightly less than 16 1/2" (42 cm) off the ground. Secure the cutter with solid (non-concrete) support blocks.
2. Shut skid steer down properly. See "**Skid Steer Shutdown Procedures**" on page 17.
3. Run height adjustment safety chain under the skid steer hitch plate to the skid steer lower hitch loop. Thread chain through the hitch loop and back toward the hitch plate. Connect quick link coupler to a chain loop as shown in **Figure 1-4**.

NOTE: When attaching the Skid Cutter to a Kubota SVL machine, height adjustment safety chain (#2) should be looped around SVL tie-down bar (#1) and adjusted so that the cutter cannot be raised over 16.5" (42 cm) off the ground as shown in Figure 1-4.

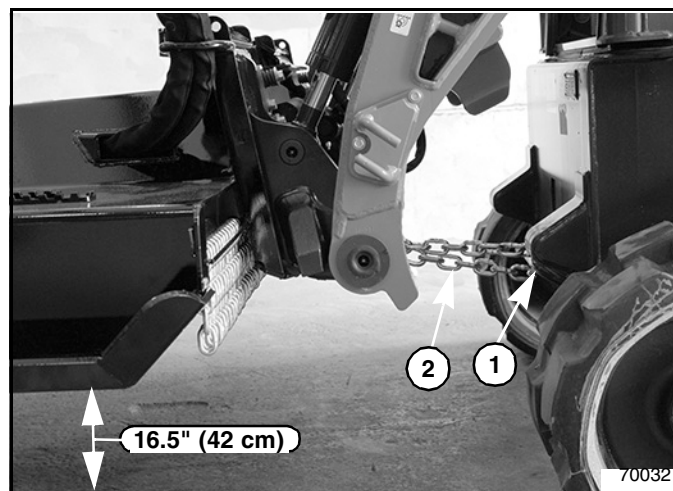

SC70 Height Adjustment (SVL Shown)
Figure 1-4

4. Raise cutter up until the safety chain is tight. Check height of rear skid shoes.
5. If rear skid shoes are more than 16 1/2" (42 cm) above ground level, lower cutter and make necessary adjustments to the safety chain to limit rear skid shoe height to 16 1/2" (42 cm) maximum.
6. Tighten quick link coupler nut to secure safety chain.

Section 1: Assembly & Set-up

Hydraulic Hose Hook-Up

Refer to Figure 1-1 on page 10:

WARNING

To avoid serious injury or death:

- Shut power machine down and release all hydraulic pressure to the equipment before connecting or disconnecting hydraulic hoses to or from the power machine.
- Hydraulic fluid under high pressure will penetrate the skin or eyes causing a serious injury. Wear protective gloves and safety glasses or goggles when working with hydraulic systems. Use a piece of cardboard or wood rather than hands when searching for leaks. If an accident occurs, seek immediate emergency medical care or gangrene may result. DO NOT DELAY.

IMPORTANT: The customer must select best way to route the hydraulic hoses. Make sure the hoses will not contact the skid steer wheels or tracks. See “Equipment Clearances” on page 15 for detailed instructions on how to check for clearances.

Refer to Figure 1-5:

1. If attaching to a Kubota SVL machine, be sure to route hydraulic hoses through hose loop (#1) on the left side of the cutter hitch as shown.

NOTE: Use of Kubota’s SVL Hose Stay is not recommended for this attachment.

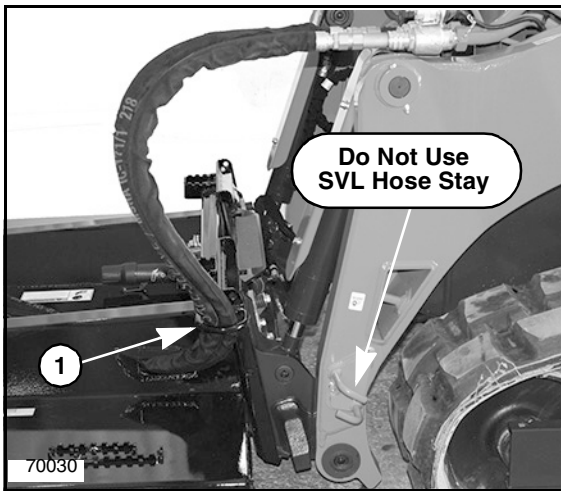

Hose Route For Kubota SVL Machine
Figure 1-5

Refer to Figure 1-1 on page 10:

2. Thread hoses through any hose holders that may be helpful on the machine operating the cutter. See your skid steer Operator’s Manual for instruction on how to use these hose holders.

3. Connect male and female couplers on the cutter to the appropriate skid steer flat faced couplers.
4. Operate skid steer to check blade rotation. The SC70 is designed to have cutter blades rotate clockwise when looking down at the deck.
5. Zip tie hydraulic hoses together every 2 feet (61 cm) from male and female couplers.

Protective Door Assembly (option)

Refer to Figure 1-6:

WARNING

To avoid serious injury or death:

Do not drill holes in the ROPS (Roll Over Protection System) to attach this Operator Protective Door. Drilling unapproved holes in the ROPS can weaken the structure.

For your safety, do not use this cutter without an installed OEM Polycarbonate Protective Operator Door. If the skid steer/track loader is not equipped with a polycarbonate door, an optional door may be purchased with the cutter.

Refer to the instructions below when installing Kubota’s optional polycarbonate door.

1. Cut notches in protective door as needed to provide clearance around u-bolts and skid steer frame.
2. Install the polycarbonate door to the skid steer’s hand hold with two u-bolts (#3), flat bars (#2), and four nuts (#1) as shown. Tighten nuts to correct torque.

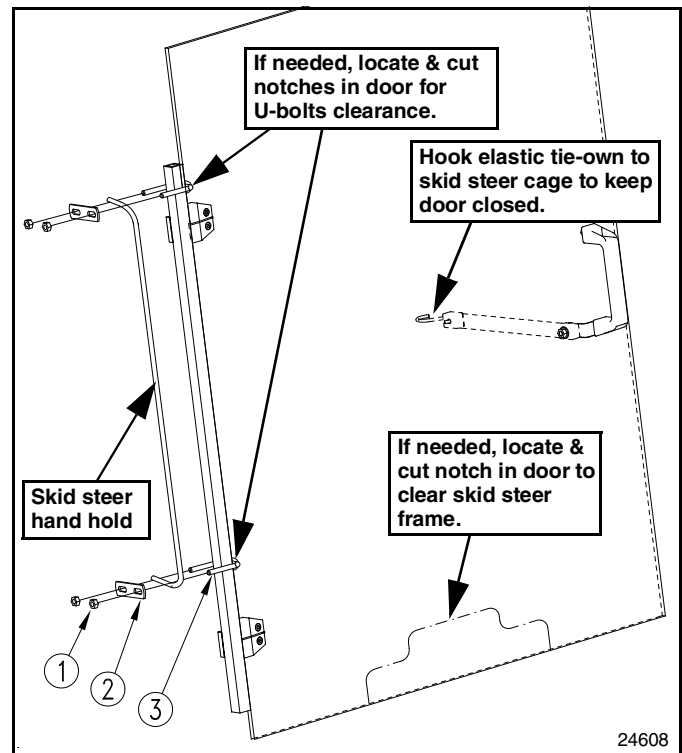

Polycarbonate Protective Door Assembly
Figure 1-6

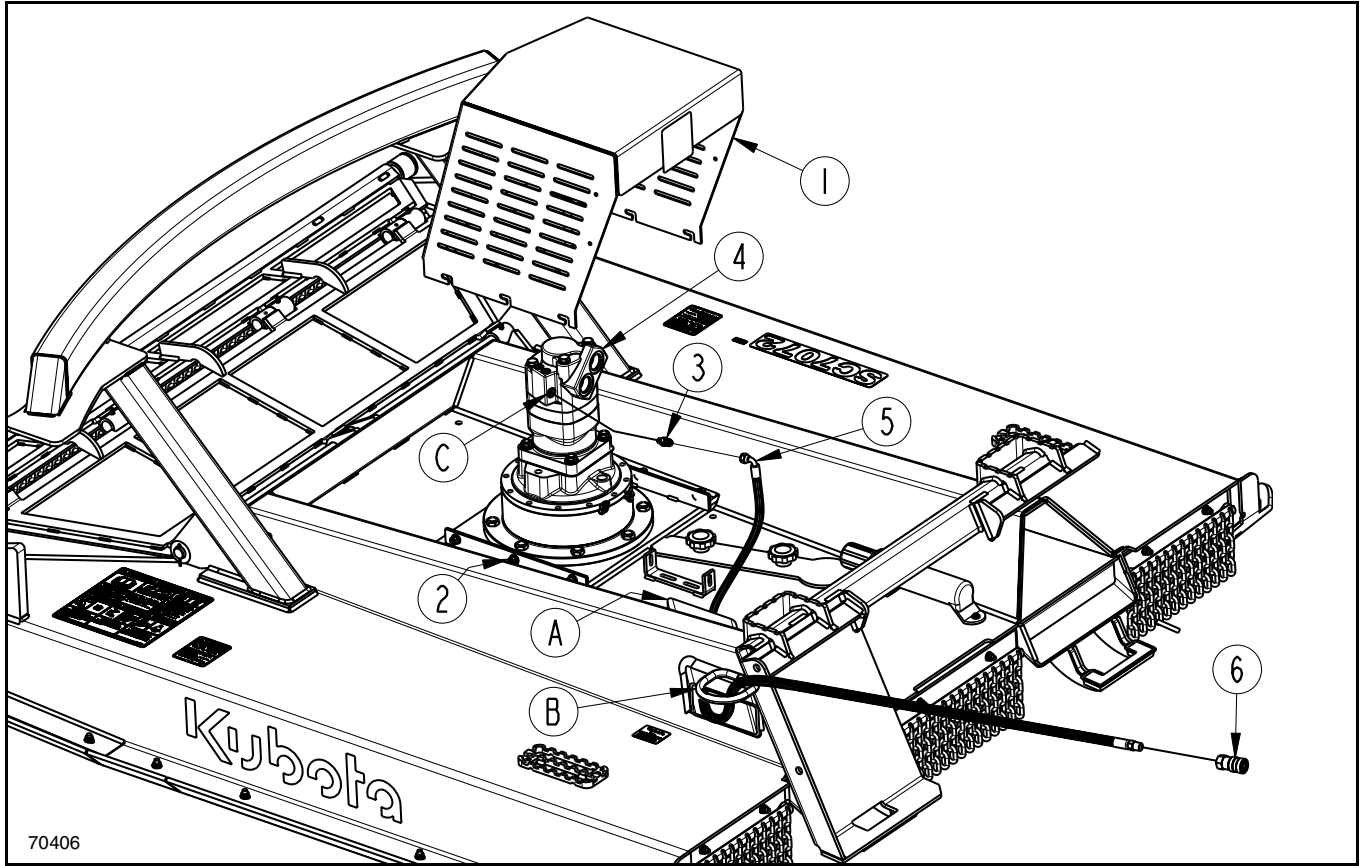

Case Drain Assembly
Figure 1-7

Case Drain Assembly (Optional)

Refer to Figure 1-7:

1. Ensure the Cutter is parked on a flat level surface, and if the cutter is attached to a skid steer, follow proper shut down procedures. See “**Skid Steer Shutdown Procedures**” on page 17.
2. Loosen six 3/8"-16 hex nuts (#2). Removing the hex nuts is not necessary.
3. Remove the motor shroud (#1) by pushing it toward the front of the unit then lifting it upward.
4. Remove plug from port (C) in hydraulic motor (#4).
5. Attach adapter fitting (#3) to port (C) in hydraulic motor (#4) as shown and tighten to correct torque.
6. Route hydraulic hose (#5) through designated areas (A & B) as shown.
7. Attach female end of hydraulic hose (#5) to adapter fitting (#3) and tighten.
8. Place the motor shroud back in its designated place and pull back to lock it in place. Tighten hex nuts (#2) to correct torque.
9. Attach flat faced coupler (#6) to the male end of hydraulic hose (#5) and tighten.
10. Connect coupler (#6) to case drain reservoir on skid steer.
11. Zip tie the case drain hydraulic hose to the two existing hoses.

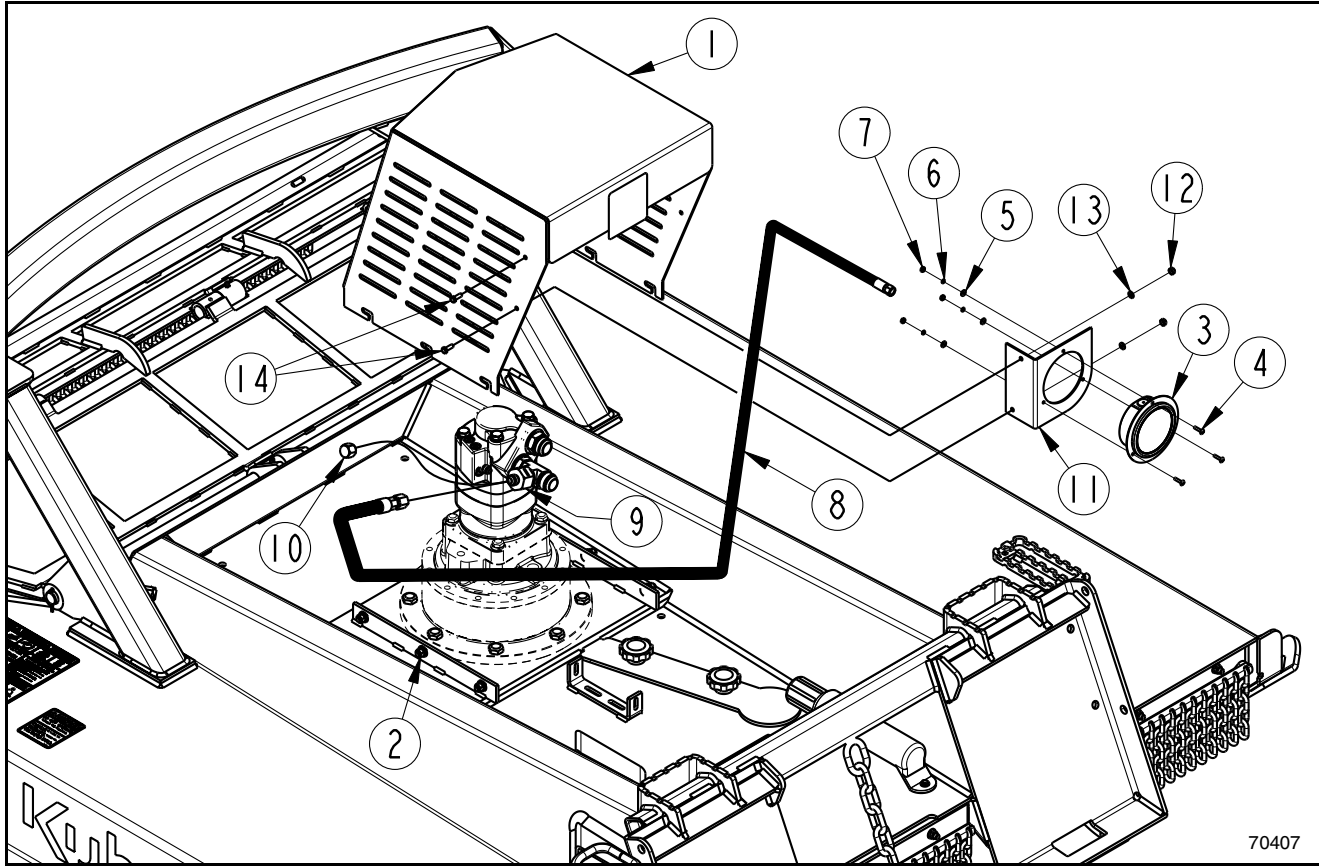

Pressure Gauge Assembly
Figure 1-8

Pressure Gauge Assembly (Optional)

Refer to Figure 1-8:

1. Ensure the Cutter is parked on a flat level surface, and if the cutter is attached to a skid steer, follow proper shut down procedures. See “**Skid Steer Shutdown Procedures**” on page 17.
2. Loosen six 3/8"-16 hex nuts (#2). Removing the hex nuts is not necessary.
3. Remove the motor shroud (#1) by pushing it toward the front of the unit then lifting it upward.
4. Remove 3/4" cap (#10) from adapter fitting (#9).
5. Attach the 3/4" end of hydraulic hose (#8) to adapter fitting (#9) and tighten.
6. Attach the pressure gauge (#3) to the pressure gauge mount (#11) using three 8-32 X 3/4" round head screws (#4). Put the screws through the holes in the pressure gauge and pressure gauge mount and fasten them with three flat washers (#5), lock washers (#6) and 8-32 hex nuts (#7). Tighten the hex nuts to correct torque.
7. Attach the 3/8" end of hydraulic hose (#8) to the pressure gauge (#3) and tighten.
8. Place the motor shroud (#1) back in its designated place and pull back to lock it in place. Tighten hex nuts (#2) to correct torque.
9. Attach the pressure gauge mount (#11) to the motor shroud (#1) using two 1/4-20 X 3/4" hex head bolts (#14). Fasten with 1/4" flat washers (#13) and 1/4-20 hex nuts (#12). Tighten to correct torque.

Equipment Clearances

Visually inspect hydraulic hoses for possible pinch points and length. Make any necessary adjustments before putting equipment into service.

1. If necessary, have someone stand nearby that can motion for the operator to stop if a problem develops while checking for clearances.
2. With deck lowered to its minimum cutting height, slowly tilt the hitch plate back raising the front of the cutter while watching for interferences between the skid steer and cutter. Make sure hydraulic hoses are long enough and do not become pinched through the full range of motion.
3. With hydraulic cylinders still retracted, slowly raise loader arms up while continuing to watch for interferences between the skid steer and cutter until height adjustment safety chain limit is reached.
4. Slowly tilt the hitch plate forward until the front of the deck is touching the ground.
5. Tilt hitch plate back until the deck looks parallel with the ground.
6. Slowly lower deck down while retracting hydraulic cylinders on end of loader arms until deck is level and resting on the ground.
7. Be sure to make any necessary corrections to the hydraulic hoses before putting cutter into service.

Section 3: Operating Procedures

Operating Checklist

Hazard control and accident prevention are dependent upon the awareness, concern, prudence, and proper training involved in the operation, transport, storage and maintenance of the Skid Cutter. Therefore, it is absolutely essential that no one operates the Skid Cutter unless they have read, fully understood, and are totally familiar with the Operator’s Manual. Make sure the operator has paid particular attention to:

- **Important Safety Information**, page 1
- **Section 1: Assembly & Set-up**, page 9
- **Section 2: Adjustments**, page 15
- **Section 3: Operating Procedures**, page 16
- **Section 5: Maintenance & Lubrication**, page 24

Perform the following inspections before using your Skid Cutter.

Operating Checklist

✓	Check	Ref.
	Make sure guards and shields are in place and secure. Make sure polycarbonate door is in good working order.	Page 1
	Inspect hydraulic hoses and replace if they are worn, damaged, or leak. Replace with genuine OEM parts.	Page 3
	Grease all fittings. Refer to “Lubrication Points”.	Page 28
	Check Skid Cutter initially and periodically for loose bolts & nuts. See “Torque Values Chart”.	Page 33

Safety Information

DANGER

To avoid serious injury or death:

- Rotary Cutters have the ability to discharge objects at high speeds; therefore, the use of front & rear safety guards is mandatory with this cutter. Stop blade rotation if bystanders are in or around the area. It is recommended that a safety shield be placed between the operator and cutter on an open air tractor.
- Keep bystanders clear while cutter is operating. Shut cutter and power machine down if a bystander is in or around the area. People can be hurt by thrown objects, rotating blades, being run over, etc.
- Always disengage auxiliary hydraulics to the cutter, shutdown the power machine, and wait for cutter blades to spool down to a stop before allowing anyone to clean, service, preform maintenance, or be near the cutter. Refer to power machine shutdown procedures provided in this manual.
- Clear area to be cut of debris and other unforeseen removable objects before cutting. Mark non-removable hazards such as tree stumps, post stubs, protruding objects, rocks, drop-offs, holes, etc. with a visible flag.

- All guards and shields must be installed and in good working condition while operating the attachment.
- Do not use cutter as a fan. Cutting blades are not properly designed or guarded for this use.
- Do not operate cutter with skid shoes any higher than 16.5" (42 cm) off the ground. Always use height adjusting safety chain to limit cutting height. Raising cutter too high will throw debris at the operator.
- Lifting cutter up without the height adjusting safety chain installed can result in the cutter making contact with an electrical power line and causing electrocution.
- Keep attachment and/or loader arms away from overhead electrical power lines. Place an orange warning sign under overhead lines indicating type of danger above.
- Do not operate cutter after dark without working lights. The equipment can hit unseen objects or be hit by other vehicles. The operator can loose control of the power unit and cutter causing a wreck or roll-over.

WARNING

To avoid serious injury or death:

- Allow only persons to operate this implement who have fully read and comprehended this manual, and who have been properly trained in the safe operation of this implement. Serious injury or death can result from the inability to read, understand, and follow instructions provided in this manual.
- Hydraulic fluid under high pressure will penetrate the skin or eyes causing a serious injury. Wear protective gloves and safety glasses or goggles when working with hydraulic systems. Use a piece of cardboard or wood rather than hands when searching for leaks. If an accident occurs, seek immediate emergency medical care or gangrene may result. **DO NOT DELAY.**
- Never carry riders on the attachment or power machine. Riders can obstruct the operator’s view, interfere with controls, be pinched by moving components, become entangled in rotating components, struck by objects, thrown about, fall off and be run over, etc.
- Do not cut on steep inclines. The power machine could flip over causing damage to the equipment and serious bodily injury or death.
- Do not operate a hammer or mulching equipment on an open cab machine or on a machine with a tempered front glass window/door. The operator **MUST** use a polycarbonate front door/window when operating a hammer or mulching equipment.
- To protect the operator from thrown objects, the skid steer or track loader **MUST** be equipped with a polycarbonate protective door, and the operator **MUST** wear eye protection such as safety glasses or goggles.
- Use caution when entering and exiting the skid steer. Maintain three points of contact. Be careful not to become entangled in hydraulic hoses while entering or exiting the skid steer operator station.

Section 3: Operating Procedures

- *Avoid catching hydraulic hoses on brush, posts, tree limbs, and other protrusions that could damage and/or break them.*
- *Do not abuse equipment. Incorrect use of the attachment can damage equipment structurally and cause serious injury or death..*
- *Do not travel too fast. The rougher the terrain, the slower you must travel. Always travel at a speed slow enough to be able to adjust the deck height before running it into the ground. Also, travel slow enough to stop before running or turning into obstacles ahead and on either side.*
- *Do not use this attachment to pull and/or pry fence posts, stumps, roots, rocks, or other objects out of the ground. It is not properly designed or guarded for this use.*
- *Do not use this attachment to lift, carry, push or tow other equipment or objects. It is not properly designed or guarded for this use. The operator could lose control resulting in equipment damage and/or tipping hazard.*
- *Do not use this attachment as a lifting device for people or as a work platform. It is not properly designed or guarded for this use.*
- *Do not operate cutter with blades that are out-of-balance, bent, excessively worn, excessively nicked, or with blade bolts that are excessively worn. Such blades can break loose at high speeds.*
- *Do not alter attachment or replace parts on the attachment with other brands. Other brands may not fit properly or meet OEM specifications. They can weaken the integrity and impair the safety, function, performance, and life of the attachment. Replace parts only with genuine OEM parts.*
- *Do not exceed rated cutting capacity of your cutter. See specifications & capacities for specified cutting capacity. Exceeding rated cutting capacity can damage drive components, cutter blades, and deck components.*
- *Cutter deck can be slippery especially when wet. Always step on anti-slip surfaces when possible. Never hurry. Make sure you have secure footing and hand hold when walking on the deck.*
- *Buildup of debris around moving components and gearboxes is a fire hazard. Keep rotating parts and gearboxes free from debris.*
- *Bi-fold door must be fully functional to help protect against thrown object and rotating blade hazards. If damaged, shutdown cutter and repair bi-fold door before putting the cutter back into service.*
- *Always shut skid steer down using “Skid Steer Shut Down Procedure” provided in this manual before dismounting to maintain and/or make adjustments to the skid steer cutter.*

Skid Steer Shutdown Procedures

The following are basic skid steer shutdown procedures. Follow these procedures and any additional shutdown procedures provided in your skid steer Operator's Manual before leaving the operator's seat.

1. Reduce engine speed and shut-off all power to the attachment.
2. Park on solid, level ground and lower attachment until it is flat on the ground or on solid (non-concrete) support blocks.
3. Turn off engine. Do not remove ignition key at this time.
4. Turn ignition key to the “RUN” position. Relieve all hydraulic pressure by moving both joysticks.
5. Turn ignition key off and remove to prevent unauthorized starting.
6. If included, raise seat bar and move controls until both lock.
7. Wait for all components to come to a complete stop before leaving the operator's seat and/or allowing bystanders near the attachment.
8. Use steps, grab-handles and anti-slip surfaces when stepping on and off the skid steer or attachment.

Transporting



WARNING

To avoid serious injury or death:

When traveling on roadways, travel in such a way that other vehicles may pass you safely. Always use LED lights, clean reflectors, and a slow moving vehicle sign that is visible from the back to warn operators in other vehicles of your presence. Always comply with all federal, state, and local laws.

1. Be sure to reduce ground speed when turning; and, leave enough clearance so the Skid Cutter does not contact obstacles such as buildings, trees, or fences.
2. Select a safe ground travel speed when transporting from one area to another. When traveling on roadways, transport in such a way that faster moving vehicles may pass you safely.
3. Decrease transport speed when traveling over rough or hilly terrain.
4. When transporting skid steer and Skid Cutter on a trailer:
 - Use towing vehicle and trailer of adequate capacity.
 - Always drive up a ramp with heavy end uphill.
 - Engage skid steer park brake and remove ignition switch key once it is loaded.
 - Secure skid steer loader and attachment using tie-downs and chains.

Section 3: Operating Procedures

Cutting Instructions

WARNING

To avoid serious injury or death:

- Do not use carbide teeth to grind anything other than wood. Grinding other objects can cause a thrown object hazard.
- Do not operate cutter with the front of the deck angled down more than 30 degrees. Exceeding this angle will result in objects being thrown from under the deck.

IMPORTANT: Do not over angle hitch plate forward. Over angling can cause damage to deck and hitch.

IMPORTANT: Do not lower operating mulcher down onto trees, saplings or bushes that are 12" (31 cm) tall.

NOTE: Your cutter is equipped with free swinging cutting blades to reduce shock loads to the cutter when striking an obstacle.

25616



DO NOT OPERATE WITH FRONT OF SKID STEER OFF THE GROUND

Figure 3-1

IMPORTANT: Refer to Figure 3-1: Do not operate cutter or navigate turns with the front of the skid steer off the ground. Operating in above fashion will cause damage to the deck & hitch.

IMPORTANT: Refer to Figure 3-2 on page 19: Deck is open in front and rear. The direction of travel while cutting should be forward & reverse. Never swing deck side to side without first raising the deck off the ground and high enough to clear all obstacles.

The Skid Cutter should be operated in one of three ways.

- If cutting grass, weeds, or light brush operate with the deck rear slightly higher than deck front.
- If cutting heavy brush, operate with the deck front 3"-5" (8-13 cm) higher than the deck rear. Lower the deck front and backup slowly mulching the debris and leveling brush root spikes to ground level.
- If cutting and mulching trees, operate by raising deck front 12"-15" (31-38 cm) higher than deck rear. Cut the tree so that it falls away from the operator. Upon tree falling, back up, then lower the deck front 6" (15 cm), drive forward to remove stump, back up, lower deck front to the ground, drive forward to mulch the stump to ground level. Lift deck front 12"-15" (31-38 cm) and repeat steps above to mulch the fallen tree.
- When cutting grass, weeds, or light brush on a steep bank, engage blades and travel straight forward toward the bank until the cutter deck is hanging over the bank. Stop traveling and tilt top of hitch plate forward to lower the front of the cutter. Continue to tilt the hitch plate and lower/raise loader arms until the cutter is parallel with the bank slope. Do not operate cutter angled more than 30 degrees down. Once a satisfactory cut has been made, disengage blades, tilt top of hitch plate back to level the cutter deck, raise/lower loader arms as need, and back away from the bank.

1. Thoroughly inspect the area to be cut for debris and unforeseen objects. Mark any potential hazards.
2. Set skid steer hydraulic lift arms and hitch angle to position the deck front at the preferred cutting height and the deck rear slightly higher.
3. Start the skid steer and engage hydraulic motor. Allow several seconds for cutter blades to become aligned properly. If deck continues to vibrate after several seconds, stop motor and inspect blades.
4. It is important to maintain correct hydraulic motor speed. Loss of motor speed will allow the blades to hinge back and result in ragged, uneven cutting.
5. Ground speed depends on two things: the density of material being cut and size of skid steer. Never run fast enough to overload the skid steer or cutter.
6. This cutter was designed to cut brush and small trees on gently sloping or slightly contoured right-of-ways, pastures, set aside acres, and row crop fields.

70751

Deck is open in front and rear.
The direction of travel while cutting
should be forward & reverse.

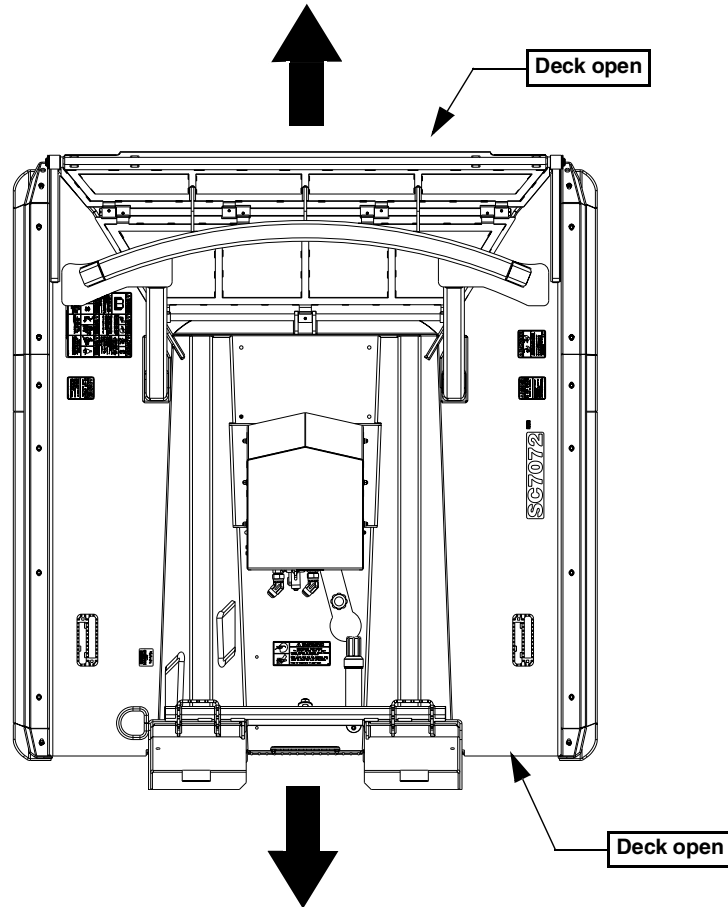

Never swing deck side to side without
first raising the deck off the ground and
high enough to clear all obstacles.

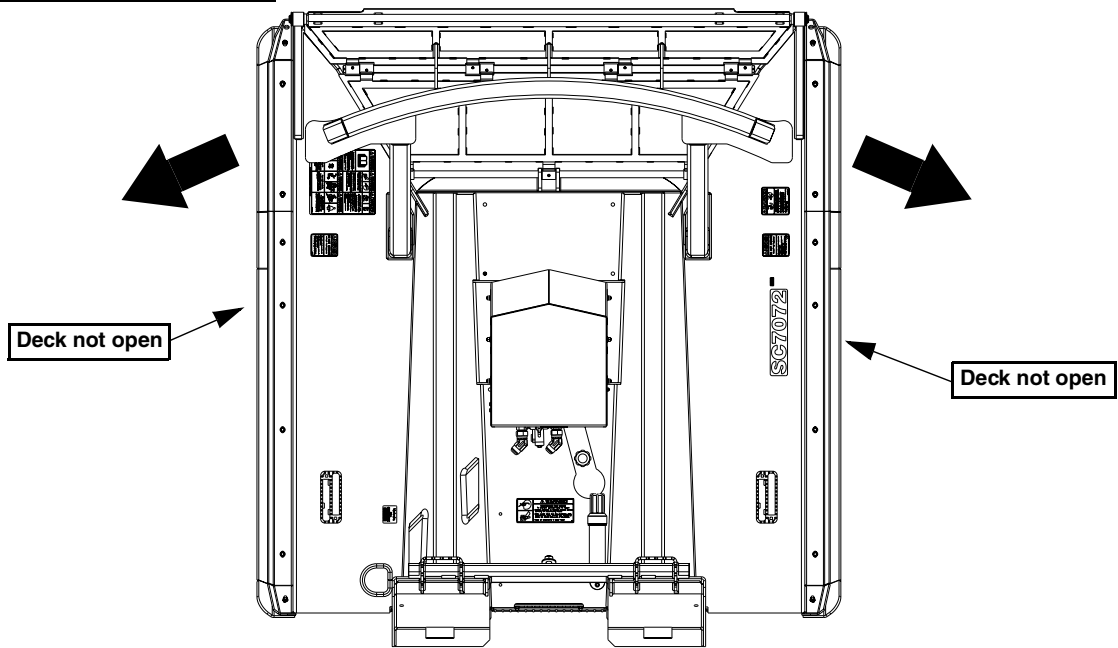

Cutting Operation
Figure 3-2

Section 3: Operating Procedures

General Operating Instructions

It is absolutely essential that you read and understand both the Operator's Manual for your Kubota Skid Cutter and the Operator's Manual for the skid steer unit you intend to attach it to before attempting to operate or cut with this combination of equipment. You must be able to read, comprehend, and adhere to all safety warnings and decals in order to avoid personal injury, fatalities, injury to others, or costly damage to property and equipment. We highly recommend that you be a skilled and competent skid steer operator prior to attaching and attempting to use the Skid Cutter. If there is any part of the information above or safe operating procedures you do not understand, please contact your nearest authorized dealer for a full explanation and training session if necessary.

If attachment is to be operated in reverse, make sure visibility to the rear of the power unit is appropriate for the attachment.

Skid Steer Operating Instructions

WARNING

To avoid serious injury or death:

To protect the operator from thrown objects, the skid steer or track loader MUST be equipped with a polycarbonate protective door, and the operator MUST wear eye protection such as safety glasses or goggles.

Assuming you have met all of the requirements and taken them seriously, it is time to take the next step and that is accomplished by dressing appropriately for the task. You will need to put on protective eye wear such as safety glasses, goggles, or a face shield. A hard hat, steel toed safety shoes, gloves, and hearing protection are also highly recommended. Never wear loose fitting clothing. A respirator or filter mask will help reduce the amount of dust, pollen, or agricultural chemicals potentially inhaled by the operator.

The next step is a static or non-running pre-inspection of the skid steer unit. You will want to make sure that the skid steer is equipped with a fully functioning ROPS (Roll Over Protective Structure) which does include seat belts and an operator safety enclosure. The cab must also be equipped with a polycarbonate operator protective door, which may have been supplied with the skid steer unit. Kubota does offer a polycarbonate operator protective door with the SC7072 if one is not provided by your skid steer supplier. If the skid steer is to be operated on local roadways, it must be equipped with appropriate Slow Moving Vehicle (SMV) and other required lighting packages so as to make it compliant with federal, state and local department of transportation requirements. The cutter drive motor must be matched to the output of the hydraulic capacity of the skid steer. Failure to do this could result in serious over-speeding of the cutting unit possibly resulting in serious injury, fatalities, or property damage.

The universal quick-hitch mount should be in good working order and latches should be located to the open position. There should be no evidence of hydraulic leaks in and around the auxiliary hydraulic couplers. There must be a readily accessible attaching point for the Skid Cutter lift-limit chain on the lower front portion of the chassis frame. Finally make sure that all shields and safety features are in place and fully functional.

The next step is to perform a running check of the skid steer unit. As you get onto the skid steer and into the operator's compartment always use factory provided hand-holds to ease or stabilize your entry. Fasten your seat belt once you are seated and begin to mentally orient yourself with the position of all controls, switches, pedals, levers, and their related functions. Once you are sure that the park brake is on, no people or animals are in close proximity, all control levers, pedals, and hydraulic systems are in neutral position, go ahead and start the engine. With the engine now running and the throttle at approximately one third, test all controls to make sure they are fully functioning. If at any time there is an equipment failure, shut the unit down and make immediate and full repairs.

For additional information, review the operator's manual for your skid steer along with the manufacturers recommended checks before operation.

Skid Cutter Operating Instructions

Once all systems with the skid steer are "go" and fully functioning, it is time to connect to your SC7072. This is done by maneuvering the skid steer mounting plate into position under the universal quick hitch top angle bar. Once this is accomplished and the mower is fully supported by the skid steer lift arms, lower mower to a point approximately two inches above ground. Turn the engine off, set the park brake, and climb out of the skid steer. Lock the latch handles down to engage the hitch pins. Connect the hydraulic hoses to the appropriate auxiliary hydraulic outlets and case drain making sure to keep connectors clean. (Note: Hydraulic flow direction on all skid steers is not the same. Make sure hoses are connected properly or blades will rotate at a much slower speed.) Connect the height limiting safety chain to the chassis attaching point and restrict cutting height to no more than eighteen inches. This completes the attachment of the cutter to the skid steer.

The next step is to complete a pre-operation check of the cutter. Make sure all guards, safety shields, safety chains, and deflectors are in place. All hardware must be in place and appropriately tightened. Damaged, severely worn, or defective parts must be replaced prior to operation.

Section 3: Operating Procedures

It is important that you inspect the area where you will be cutting and clear it of hazards and foreign objects before you start mowing. Never assume the area is clear. Cut only in areas you are familiar with and are free of foreign objects. Extremely tall grass should be cut twice to detect potential hazards. In the event you do strike an object, stop the cutter and tractor immediately to inspect and make any necessary repairs to the cutter before resuming operation. Remove or clearly mark the struck object to prevent hitting it again. It really pays to inspect a new area and to develop a safe plan before cutting.

No one, including people and animals, should be allowed within 100 yards (91 m) of this cutter when in operation. If someone does approach, shut the cutter down immediately. The blades on this cutter should never be allowed to come in contact with objects such as wire, cable, rope, or chains that might become entangled. These types of entangled objects can become extremely hazardous by rotating outside of the cutter deck housing resulting in serious injury or death. Always inspect the area before you mow.

The best mowing results will be achieved at speeds up to 2 mph (3.2 km/h) or as vegetation and ground conditions dictate. If you are mowing in particularly tall or dense brush, you may want to make two passes with the first pass being higher and the second pass made as a cross-cut at the desired cut height. The pressure gauge option enables the operator to determine the ground speed obtainable without stalling the cutter. When operating with a pressure gauge the pressure reading should be up to within 500 PSI of the skid steer's output. Example: skid steer output = 3500 PSI, if the operator adjusts the ground speed so the pressure gauge reading is up to 3000 PSI then the cutter will not stall. If the ground speed causes the pressure to increase to 3500 PSI the cutter will stall and the blades will stop rotating. Conversely, if the pressure reading is less than 3000 PSI, the operator can increase their ground speed if desired. Driving too fast over uneven ground will cause the unit to undulate in a forward pitching motion. Only increase the ground speed when you are comfortable with how the complete system responds in various terrain.

The Skid Cutter should be operated in one of four ways.

1. If cutting grass, weeds, or light brush operate with the deck rear slightly higher than deck front.
2. If cutting heavy brush, operate with the deck front 3"-5" (8-13 cm) higher than the deck rear for the length of the cutter. Lower the deck front and backup slowly mulching the debris and leveling brush root spike to ground level.
3. If cutting and mulching trees, operate by raising deck front 12"-15" (31-38 cm) higher than deck rear. Cut the tree so that it falls away from the operator. Upon tree falling, back up, then lower the deck front 6" (15 cm), drive forward to remove stump, back up, lower deck front to the ground, drive forward to mulch the stump to ground level. Lift deck front 12"-15" (31-38 cm) and repeat the steps above to mulch the fallen tree.
4. When cutting grass, weeds, or light brush on a steep bank, engage blades and travel straight forward toward the bank until the cutter deck is hanging over the bank. Stop traveling and tilt top of hitch plate forward to lower the front of the cutter. Continue to tilt the hitch plate and lower/raise loader arms until the cutter is parallel with the bank slope. Do not operate cutter angled more than 30 degrees down. Once a satisfactory cut has been made, disengage blades, tilt top of hitch plate back to level the cutter deck, raise/lower loader arms as need, and back away from the bank.

IMPORTANT: Use of this Skid Cutter is limited to standard brush cutting. Use in significantly larger or denser brush will result in excessive heat and may damage the Skid Cutter or the skid steer.

When you do need to stop, make sure you set the park brake, shut the skid steer engine off, and allow time for the blades to stop rotating before you exit the power unit. With a little practice we are confident you will soon achieve safe and excellent results with your new Kubota SC7072 Skid Cutter.

Section 4: Options & Accessories

Pressure Gauge Bundle (Option)

Refer to Figure 4-1:

Pressure Gauge Bundle 326-928A

Kubota offers an optional motor pressure gauge for the SC7072 that allows for the operator to ensure the motor is operating at optimal psi.

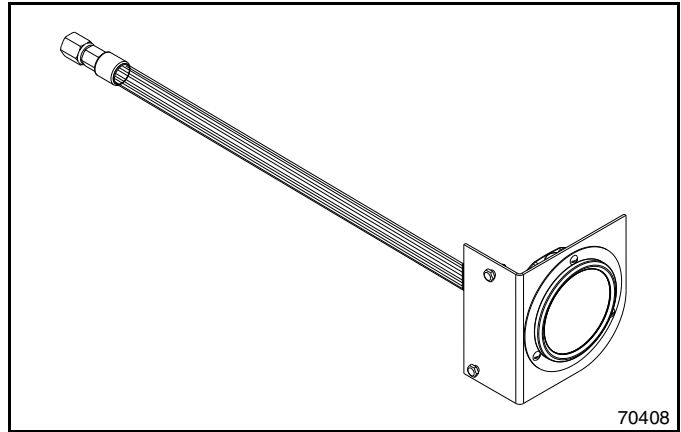

**Pressure Gauge Bundle
Figure 4-1**

Case Drain Bundle (Option)

Refer to Figure 4-2:

Case Drain Bundle 326-925A

Kubota offers an optional case drain bundle for the SC7072 to protect the hydraulic motor and seals from excessive pressure.

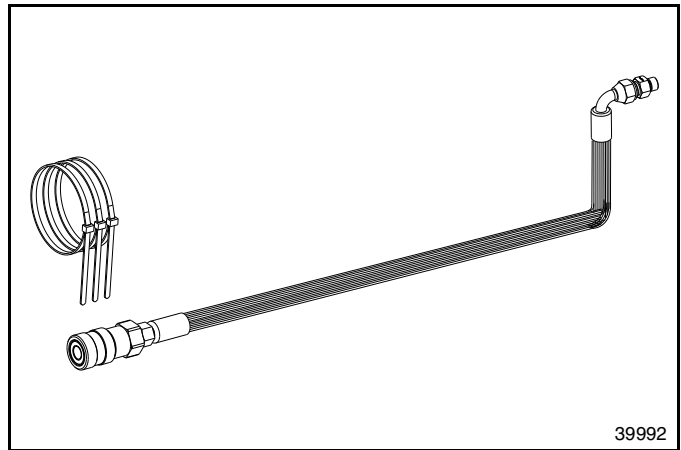

**Case Drain Bundle
Figure 4-2**

Narrow Skid Shoes (Accessory)

Refer to Figure 4-4:

Skid Shoe Bundle Narrow SC7072 327-302A

Kubota offers the narrow skid shoe bundle complete with mounting hardware for the SC7072. The skid shoes allows the cutter to fit in narrow spaces primarily for transport.

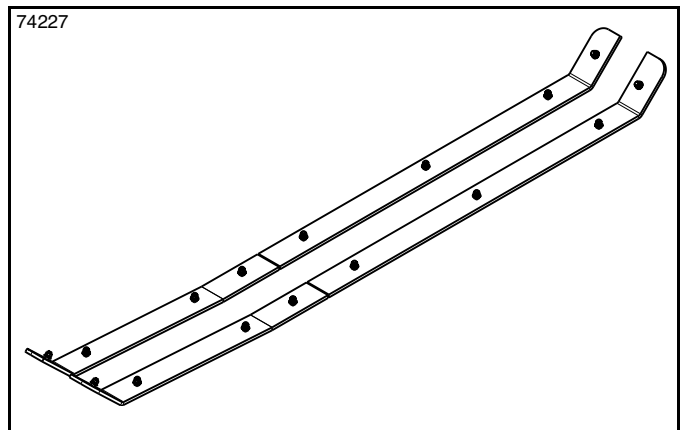

**Narrow Skid Shoes
Figure 4-4**

Polycarbonate Protective Door (Option)

Refer to Figure 4-5:

Polycarbonate Protective Door. 326-024A

The skid steer or track loader **MUST** be equipped with an OEM Polycarbonate Operator Protective Door for shielding against flying debris when attached to a Rotary Cutter. Kubota offers a universal polycarbonate door shield that attaches to your skid steer hand hold with two u-bolts. Some notching in the shield may be required to fit your particular skid steer model. See **“Protective Door Assembly (option)”** on page 12 for additional information.

The owner may choose to use a polycarbonate protective door provided by their skid steer supplier. Kubota offers a Operator Protective Door Kit #S6686 which can be used with the Kubota SVL. See your nearest Kubota dealer if purchasing this kit.

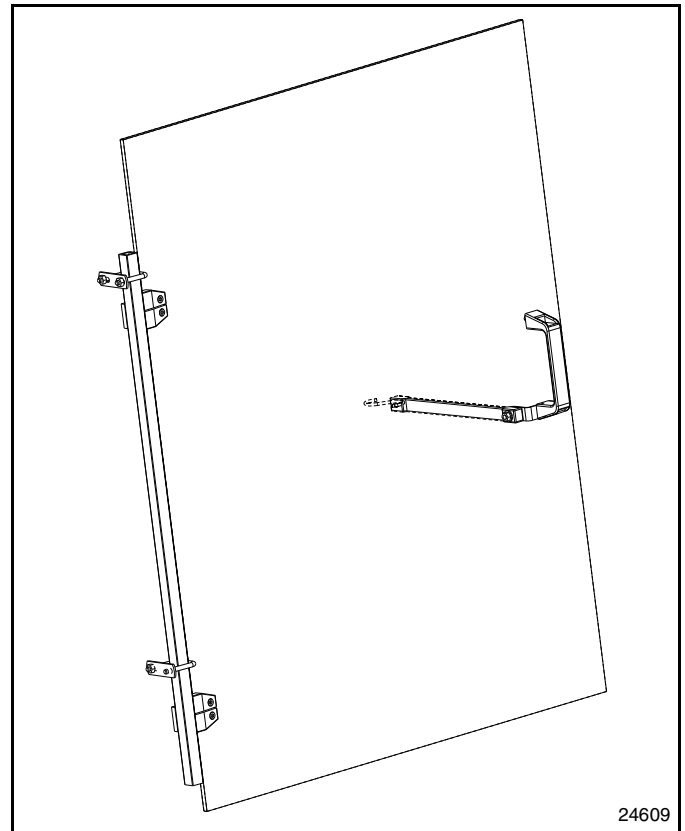

Polycarbonate Protective Door
Figure 4-5

Section 5: Maintenance & Lubrication

Maintenance

Proper servicing and adjustment are key to the long life of any attachment. With careful inspection and routine maintenance, you can avoid costly downtime and repair.

Check all bolts after using unit for several hours to be sure they are tight. Replace any worn, damaged, or illegible safety labels by obtaining new labels from your Kubota dealer.

The parts on your cutter have been specially designed and should only be replaced with genuine Kubota parts. Do not alter the cutter in a way which will adversely affect its performance.



DANGER

To avoid serious injury or death:

- Always disengage power take-off, shut tractor down, and wait for cutter blades to spool down to a stop before allowing anyone to clean, service, perform maintenance, or be near the cutter. Refer to tractor shutdown procedures provided in this manual.
- Always secure equipment with solid, non-concrete supports before working under it. Never go under equipment supported by concrete blocks or hydraulics. Concrete can break, hydraulic lines can burst, and/or hydraulic controls can be actuated even when power to hydraulics is off.



WARNING

To avoid serious injury or death:

- Do not alter attachment or replace parts on the attachment with other brands. Other brands may not fit properly or meet OEM specifications. They can weaken the integrity and impair the safety, function, performance, and life of the attachment. Replace parts only with genuine OEM parts.
- Buildup of debris around moving components and gearboxes is a fire hazard. Keep rotating parts and gearboxes free from debris.
- Make sure controls are all in neutral position or park before starting the power machine.

Hydraulic Maintenance



WARNING

To avoid serious injury or death:

Hydraulic fluid under high pressure will penetrate the skin or eyes causing a serious injury. Wear protective gloves and safety glasses or goggles when working with hydraulic systems. Use a piece of cardboard or wood rather than hands when searching for leaks. If an accident occurs, seek immediate emergency medical care or gangrene may result. **DO NOT DELAY.**

One of the most important things you can do to prevent hydraulic system problems is to ensure that your skid steer reservoir remains free of dirt and contamination.

Use a clean cloth to wipe the hose ends before attaching them to your skid steer. Replace the filter element for your skid steer's hydraulic system at the prescribed intervals. These simple maintenances will go a long way to prevent occurrence of hydraulic problems.

Cutter Blade Maintenance



WARNING

To avoid serious injury or death:

- Always shut power machine down using the "Shutdown Procedure" provided in this manual before servicing, adjusting, cleaning, or maintaining the attachment.
- Do not operate cutter with blades that are out-of-balance, bent, excessively worn, excessively nicked, or with blade bolts that are excessively worn. Such blades can break loose at high speeds.

IMPORTANT: Replace blades in sets with genuine OEM blades only. It is highly recommended to replace blades in sets. Not replacing blades in sets will result in an out-of-balance condition that could contribute to premature bearing wear/breakage and/or structural cracks in gearbox and/or deck.

Always inspect blades before each use. Make certain they are properly installed and in good working condition. Blades that are damaged, worn, bent, or excessively nicked should be replaced. Never try to straighten a bent blade! Small nicks can be ground out when sharpening.

Remove cutting blades and sharpen or replace as follows:

1. Properly shut down skid steer according to your skid steer Operator's Manual.
2. Secure cutter deck in a raised position with solid supports before servicing underside of cutter.
3. **Refer to Figure 5-1 on page 25:** Remove the deck access cover.
4. **Refer to Figure 5-2 on page 25:** Rotate blade carrier until 3/4" hex lock nuts (#1) are aligned with the deck access hole.

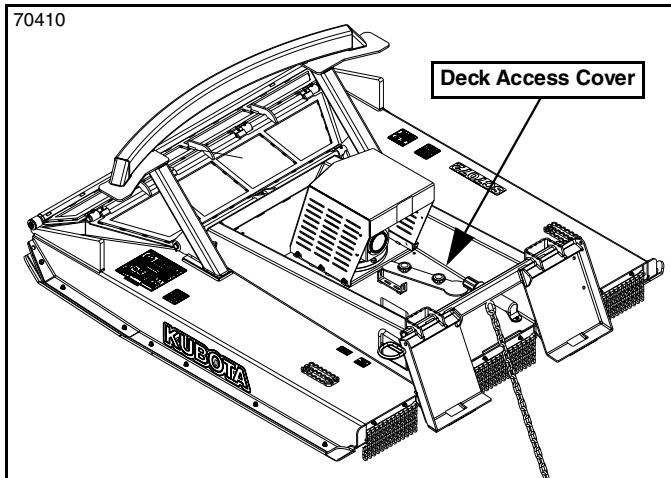

Deck Access Cover Location
Figure 5-1

5. Unscrew three 3/4" hex lock nuts (#1) to remove cutting blade (#4) and blade retainer (#3).
6. Blades should be sharpened at the same angle as the original cutting edge and must be replaced or re-ground at the same time to maintain proper balance in the cutting unit. The following precautions should be taken when sharpening blades:

NOTE: The blades are double edged and can be flipped over and re-used after one side gets worn. The blades must be assembled as shown in **Figure 5-2**, alternating one blade right side up and the next upside down to achieve optimal cut.

- a. Do not remove more material than necessary.
- b. Do not heat and pound out a cutting edge.
- c. Do not grind blades to a razor edge. Leave a blunt cutting edge approximately 1/16" (2 mm) thick.
- d. Always grind cutting edge so end of blade remains square to cutting edge and not rounded.
- e. Blades should weigh the same with not more than 1 1/2 oz. (43 gm) difference. Unbalanced blades will cause excessive vibration which can damage gearbox bearings and create structural cracks.

Refer to Figure 5-2:

IMPORTANT: Examine bolts, washers, and nuts for excessive wear and replace if worn.

7. Insert three 3/4-10 x 3 GR8 bolts (#5) through the blade carrier bottom (#10), blade retainer (#3), cutter blade (#4), blade carrier top (#9), and lock washers (#2). Secure with three 3/4" hex lock nuts (#1).
8. Torque 3/4" hex lock nuts (#1) to the correct torque for a 3/4-10 GR8 bolt.

IMPORTANT: After 20 hours of operation, retighten hex lock nuts (#1) to the correct torque once more.

9. **Refer to Figure 5-1:** Replace blade bolt access cover.

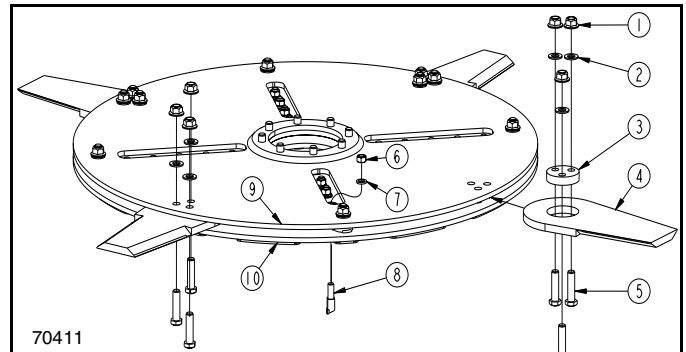

Kubota Cutter Blade Parts

#	Part No.	Part Description
1	803-299C	HEX HEX FLANGE TOP LOCK NUT
2	804-025C	FLAT WASHER
3	820-677C	BLADE RETAINER
4	820-676C	CUTTER BLADE
5	842-562C	HEX HEAD 3/4-10x3 GR8 BOLT
6	803-022C	HEX NUT
7	804-022C	LOCK WASHER
8	820-491C	CARBIDE TOOTH
9	326-916H	BLADE CARRIER TOP
10	326-915H	BLADE CARRIER BOTTOM

Cutter Blade Assembly
Figure 5-2

Carbide Teeth Maintenance

Inspect the carbide teeth before each use. Make certain they are properly installed and in good working condition. Teeth that are damaged, worn, bent, or excessively nicked should be replaced.

Remove carbide teeth and replace as follows:

1. Properly shut down skid steer according to your skid steer Operator's Manual.
2. Secure cutter deck in a raised position with solid supports before servicing underside of cutter.
3. Examine carbide teeth to determine which ones need replaced.
4. **Refer to Figure 5-1:** Remove the deck access cover.
5. **Refer to Figure 5-2:** Rotate blade carrier until 5/8" hex nuts (#6) are aligned with the deck access hole.
6. Unscrew 5/8" hex nut (#6) to remove carbide tooth (#8) that needs replaced.
7. Insert new carbide tooth (#8) through the blade carrier bottom (#10). Keep in mind the cutter rotates clockwise so the carbide teeth must be assembled accordingly.
8. Fasten with lock washer (#7) and 5/8" hex nut (#6).
9. Tighten nuts to correct torque.

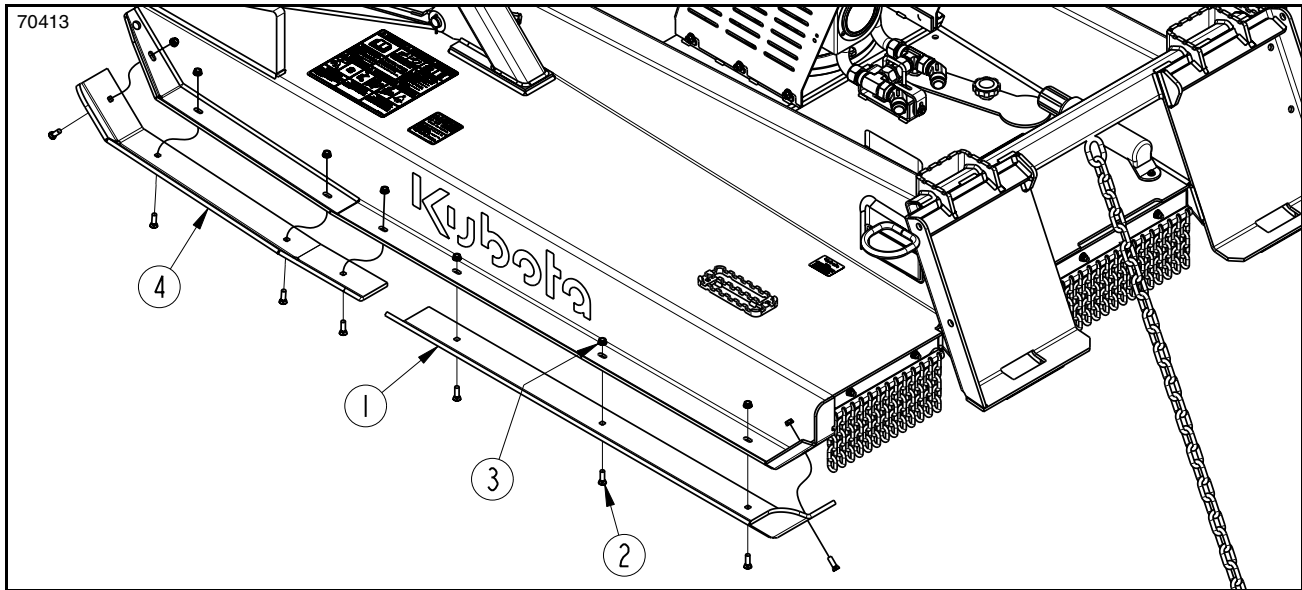

Skid Shoe Replacement
Figure 5-3

Skid Shoe Maintenance

WARNING

To avoid serious injury or death:

Excessive wear on skid shoes can damage side panels, cause inadequate operation of cutter, and create a safety hazard. Always replace skid shoes at the first sign of wearing thin.

Skid shoes should be inspected at the beginning of each cutting season and replaced when material thickness is less than 1/8" (3 mm) at any point or if other damage is evident. Order only genuine Kubota parts from your local Kubota dealer.

Refer to Figure 5-3:

Replace skid shoes as follows:

1. Raise the Skid Cutter 3" (8 cm) or more off the ground and place solid (non-concrete) support blocks under the cutter. Make sure the solid (non-concrete) support blocks are positioned so they will not interfere with skid shoe installation.
2. Lower cutter onto solid (non-concrete) support blocks, place skid steer in park, set park brake, shut the skid steer off and remove switch key.
3. Remove the hardware securing both skid shoes (#1 & #4) from each side of the deck.

4. Plow bolts (#2) should be checked for wear and replaced if necessary.
5. Install the new skid shoes (#1 & #4) to one side of the deck as shown with 3/8"-16 GR5 plow bolts (#2), and 3/8" hex whiz nuts (#3). Tighten nuts to correct torque.
6. Repeat step 5 for other side of the deck.
7. Raise cutter up and remove from solid (non-concrete) support blocks.

Skid Shoe Parts		
#	Part No.	Part Description
1	326-909H	SKID SHOE REAR LH
1	326-908H	SKID SHOE REAR RH
2	802-466C	PLOW 3/8"-16X1 1/4" GR5
3	803-198C	NUT HEX WHIZ 3/8"-16 PLT
4	326-910H	SKID SHOE FRT LH
4	326-907H	SKID SHOE FRT RH

Section 5: Maintenance & Lubrication

Long-Term Storage

Clean, inspect, service, and make necessary repairs to the SC7072 when storing it for long periods and at the end of the season. This will help to ensure the unit is ready for field use the next time you hook-up to it.



DANGER

To avoid serious injury or death:

Always secure equipment with solid, non-concrete supports before working under it. Never go under equipment supported by concrete blocks or hydraulics. Concrete can break, hydraulic lines can burst, and/or hydraulic controls can be actuated even when power to hydraulics is off.



WARNING

To avoid serious injury or death:

- Always shut power machine down following the “Shutdown Procedure” provided in this manual before leaving the operator’s station.
- Do not alter attachment or replace parts on the attachment with other brands. Other brands may not fit properly or meet OEM specifications. They can weaken the integrity and impair the safety, function, performance, and life of the attachment. Replace parts only with genuine OEM parts.

Clean the Skid Cutter at the end of the working season or when the cutter will not be used for a long period.

1. Clean off any dirt or grease that may have accumulated on the cutter and moving parts. Scrape off compacted dirt from the bottom of the deck and then wash the surface thoroughly with a garden hose. A coating of oil may also be applied to the lower deck area to minimize oxidation.
2. Check blades, carbide teeth and hardware for wear and replace if necessary. See “**Cutter Blade Maintenance**” on page 24 and “**Carbide Teeth Maintenance**” on page 25.
3. Inspect for loose, damaged, or worn parts and adjust or replace as needed.
4. Repaint parts where paint is worn or scratched to prevent rust.

5. Replace all damaged or missing decals.
6. Lubricate as noted in the *Lubrication* portion of this section starting on page 28.
7. Store the Skid Cutter in a clean, dry place. The deck should be positioned on a flat surface to suitable skid steer hook-up height. Ensure that the main frame is stable.

Touch-Up Paint

Part No.	Part Description
821-070C	Gloss black enamel spray can
821-070CTU	Gloss black enamel bottle with brush
821-070CQT	Gloss black enamel quart
821-070CGL	Gloss black enamel gallon

Lubrication Points

Lubrication Legend	Multi-purpose spray lube	Multi-purpose grease lube	Multi-purpose oil lube	50 Hrs Intervals in hours at which lubrication is required

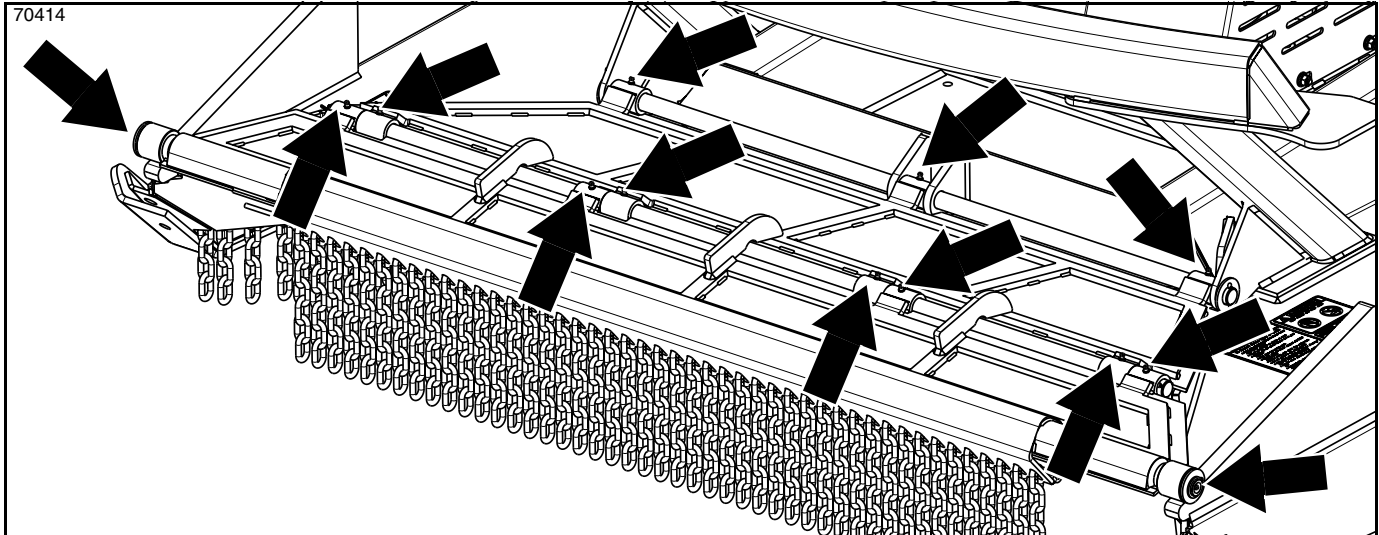

Bi-Fold Door

13- Zerks

Type of Lubrication: Multi-purpose Grease

Quantity = As required

	25 Hours
--	-----------------

	8 Hrs.
--	---------------



In Line Bearing Housing Lubrication

In Line Bearing Housing

The motor spindle hub has two 1/2" pipe plugs located on top side of deck housing.

1. Disengage blade hydraulics. Make sure blades have come to a complete stop.
2. Set cutter down on level ground.
3. Set park brake, shut engine off, and remove switch key before continuing.
4. Remove 1/2" dip stick. The end of the dipstick should have fluid on it. If it does not, add fluid.
5. Alternate method: Dip a tape measure 3/4" through the hole as shown. The end of the tape measure should have fluid on it. If it does not, add fluid.
6. Add EP 80-90 weight gearlube as required. Full capacity of motor housing is approximately 10 oz.
7. Re-install dipstick and tighten.
8. Remove magnetic plug opposite side of dipstick. Check for metal filings and clean annually.

SC7072 Skid Cutter

Specifications & Capacities

Specifications & Capacities		
Cutter weight with skid shoes	lbs (kg)	2580 (1170.3)
Hitch		Welded on
Cutting width	in (m)	73 1/2 (1.87)
Overall width	in (m)	84 3/8 (2.15)
Overall length	in (m)	92 1/4 (2.34)
Cutting height	in (cm)	1 1/2 (3.8) to 18 (45.7) infinitely variable.
Cutting capacity	in (cm)	7 (17.8) Diameter
Spindle hub oil capacity	oz (kg)	85 (2.41)
Spindle hub oil		EP 80-90 wt. gearlube
High volume drive motor	gpm (Lpm)	26-43 (98.4-162.8) flow
Hydraulic pressure	psi (mPa)	Up to 3500 (24.1)
Deck thickness	in (mm)	1/4 (6)
Side skirt construction	in (mm)	1/4 (6) Steel
Deck wear protection		Four, corner-mounted skid shoes
Skid shoe construction	in (mm)	3/8 (10) plate
Blade carrier	in (mm)	(2) Round 1/2 (13) plate weldments
Blade size	in (mm)	3/4 (19) double edge
Blade rotation		Clockwise
Blade bolt		3/4-10 Grade 8
blade tip speed	fpm (mps)	14870 (75.5) at 43 gpm (162.8 Lpm)
Front deck protection		Bi-fold door with single row chain guard
Rear deck protection		Single row chain guard
Deck lift height protection		Height adjustment safety chain
Mulching teeth	in (mm)	3/4 (19) SQ carbide
Optional protective door material & assembly weight	lbs (kg)	Clear polycarbonate shield 10 lbs (4.5)

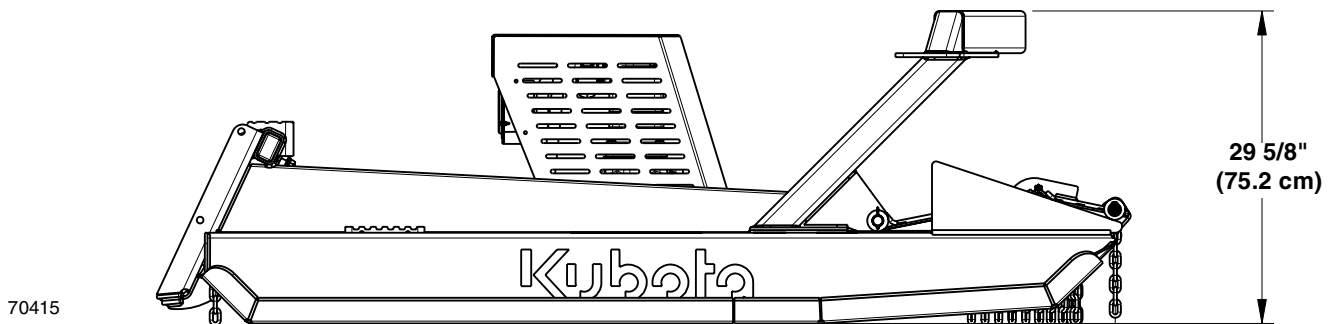
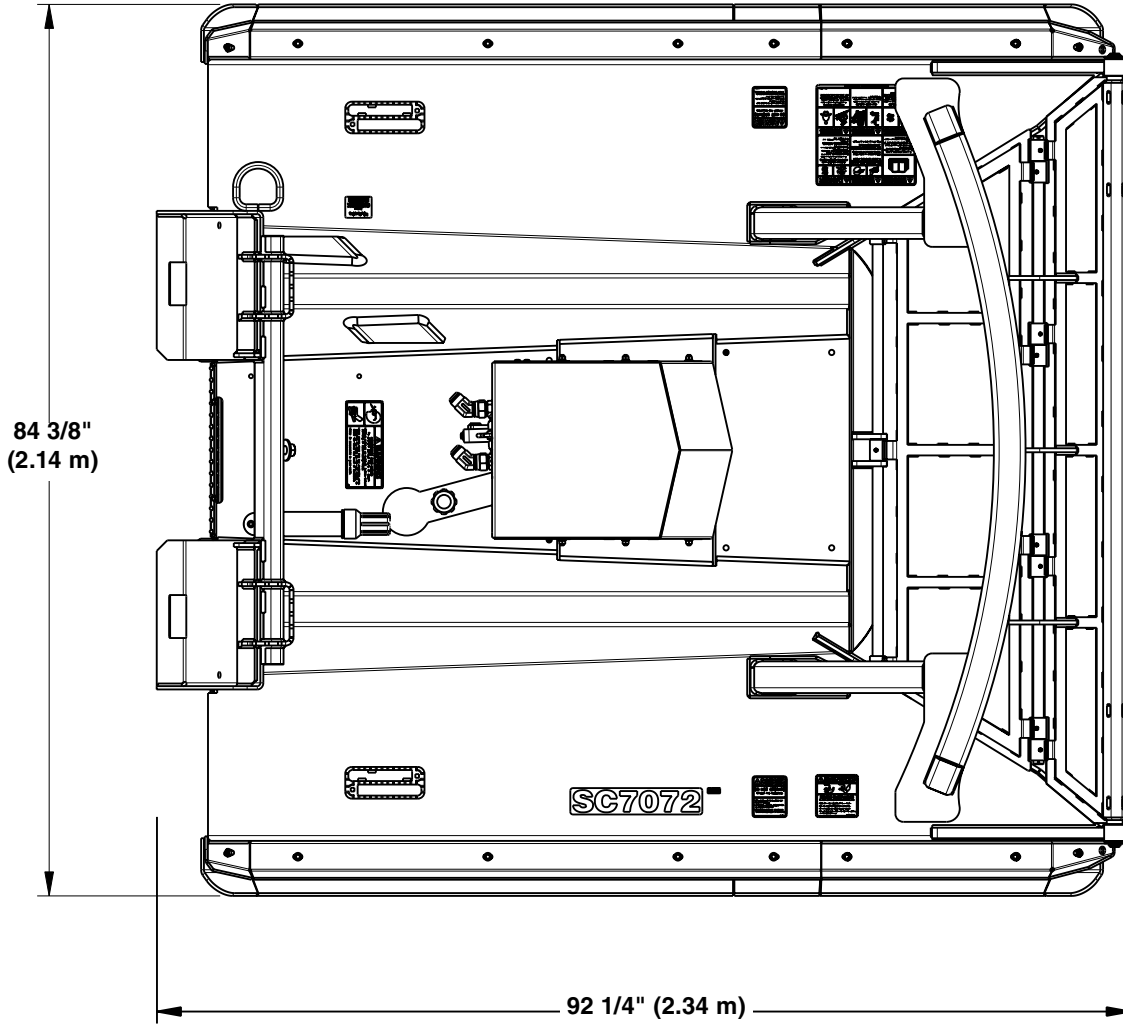

SC7072

Features	Benefits
Case drain (optional)	Protects hydraulic motor and seals.
Front and rear chain guards	Chain guards on the front and rear of deck. Reduces flying debris.
Replaceable skid shoes	Protect side plate structure. Shoes are replaceable for convenience.
3/4" x 7-1/2" free-swinging blades	Free-swinging blades protect from obstructions.
7" (18 cm) cutting capacity	Easily cuts brushy areas & trees up to 7" (18 cm) in diameter.
Carbide teeth (standard)	Grind down tree stumps.
Push Bar	Pushes cut trees away from the operator cab.
Motor pressure gauge (optional)	Allows the operator to slow down to prevent stalling.
Bi-Folding door	Door will fold open when cutting heavy brush and trees. Covers the cutting chamber when not cutting in heavy brush.
Height adjustment safety chain	Provides additional operator protection from flying objects by allowing the Skid Cutter to only be lifted up to 18" (46 cm).
1/4" (6 mm) thick deck	Heavy deck design holds up to harsh conditions.
Heavy blade carrier	Provides inertia & strength for cutting trees and grinding stumps.
Surpassed rugged industry standards	All Kubota Cutters have been designed and tested to meet rigorous voluntary testing procedures according to ISO 4254-13.
Polycarbonate door (optional)	Provides layer of protection between the cutter and operator.
1/4"(6 mm) side panels	Reduces debris piercing possibilities. Can be replaced if damaged.
Beveled skid shoes on wings	Reduces gouging the ground when turning.

Troubleshooting Chart

Problem	Cause	Solution
Motor Oil Seal Leaking	Return line from motor has been pinched or is collapsed.	Replace lower seal of motor. Check motor return hose for kinks.
	Case drain line is not properly connected.	Connect case drain line to the hydraulic motor and skid steer reservoir.
Spindle Hub Seal Leaking	Seal is worn or torn.	Replace spindle hub output shaft seal.
Blades wearing excessively	Cutting on sandy ground.	Raise cutting height.
	Contacting ground frequently.	Raise cutting height.
Blades coming loose	Blade bolts not tightened properly.	Use new nut and torque blade bolt nuts to correct torque.
Blade carrier becomes loose	Running loose in the past.	Replace gearbox output shaft and blade carrier.
	Blade carrier hardware not tight enough.	Tighten to specified torque.
Blade bolt holes worn	Blade hardware running loose.	Replace blades and blade bolts if worn.
	Not maintaining tip speed.	Slow down to maintain tip speed.
Blades breaking	Hitting solid objects.	Thoroughly check the cutting area BEFORE beginning to cut. Be alert during cutting.
Blade carrier bent	Hitting solid objects.	Avoid solid objects/Be alert. Replace blade carrier.
Excessive skid shoe wear	Cutting height not level.	Adjust deck height or replace.
	Soil abrasive.	Raise cutting height.
	Cutting too low.	Raise cutting height.
Excessive vibration	Locked blades.	Inspect and unlock blades.
	Blades have unequal weight.	Replace blades in sets of 4.
	Blade carrier bent.	Replace blade carrier.

Torque Values Chart for Common Bolt Sizes													
Bolt Size (inches)	Bolt Head Identification						Bolt Size (Metric)	Bolt Head Identification					
	Grade 2		Grade 5		Grade 8			Class 5.8		Class 8.8		Class 10.9	
in-tpi ¹	N · m ²	ft-lb ³	N · m	ft-lb	N · m	ft-lb	mm x pitch ⁴	N · m	ft-lb	N · m	ft-lb	N · m	ft-lb
1/4" - 20	7.4	5.6	11	8	16	12	M 5 X 0.8	4	3	6	5	9	7
1/4" - 28	8.5	6	13	10	18	14	M 6 X 1	7	5	11	8	15	11
5/16" - 18	15	11	24	17	33	25	M 8 X 1.25	17	12	26	19	36	27
5/16" - 24	17	13	26	19	37	27	M 8 X 1	18	13	28	21	39	29
3/8" - 16	27	20	42	31	59	44	M10 X 1.5	33	24	52	39	72	53
3/8" - 24	31	22	47	35	67	49	M10 X 0.75	39	29	61	45	85	62
7/16" - 14	43	32	67	49	95	70	M12 X 1.75	58	42	91	67	125	93
7/16" - 20	49	36	75	55	105	78	M12 X 1.5	60	44	95	70	130	97
1/2" - 13	66	49	105	76	145	105	M12 X 1	90	66	105	77	145	105
1/2" - 20	75	55	115	85	165	120	M14 X 2	92	68	145	105	200	150
9/16" - 12	95	70	150	110	210	155	M14 X 1.5	99	73	155	115	215	160
9/16" - 18	105	79	165	120	235	170	M16 X 2	145	105	225	165	315	230
5/8" - 11	130	97	205	150	285	210	M16 X 1.5	155	115	240	180	335	245
5/8" - 18	150	110	230	170	325	240	M18 X 2.5	195	145	310	230	405	300
3/4" - 10	235	170	360	265	510	375	M18 X 1.5	220	165	350	260	485	355
3/4" - 16	260	190	405	295	570	420	M20 X 2.5	280	205	440	325	610	450
7/8" - 9	225	165	585	430	820	605	M20 X 1.5	310	230	650	480	900	665
7/8" - 14	250	185	640	475	905	670	M24 X 3	480	355	760	560	1050	780
1" - 8	340	250	875	645	1230	910	M24 X 2	525	390	830	610	1150	845
1" - 12	370	275	955	705	1350	995	M30 X 3.5	960	705	1510	1120	2100	1550
1-1/8" - 7	480	355	1080	795	1750	1290	M30 X 2	1060	785	1680	1240	2320	1710
1-1/8" - 12	540	395	1210	890	1960	1440	M36 X 3.5	1730	1270	2650	1950	3660	2700
1-1/4" - 7	680	500	1520	1120	2460	1820	M36 X 2	1880	1380	2960	2190	4100	3220
1-1/4" - 12	750	555	1680	1240	2730	2010	¹ in-tpi = nominal thread diameter in inches-threads per inch ² N · m = newton-meters ³ ft-lb= foot pounds ⁴ mm x pitch = nominal thread diameter in millimeters x thread pitch						
1-3/8" - 6	890	655	1990	1470	3230	2380							
1-3/8" - 12	1010	745	2270	1670	3680	2710							
1-1/2" - 6	1180	870	2640	1950	4290	3160							
1-1/2" - 12	1330	980	2970	2190	4820	3560							
Torque tolerance + 0%, -15% of torquing values. Unless otherwise specified use torque values listed above. All locknuts or lubricated fasteners: Use 75% of torque value. (i.e. 1/2"-13 GR5 = 76 ft-lb; 75% of 76 or .75 x 76 = 57 ft-lb)													
Additional Torque Values													
Carbide Tooth Nut							110 ft-lb (150 N · m)						

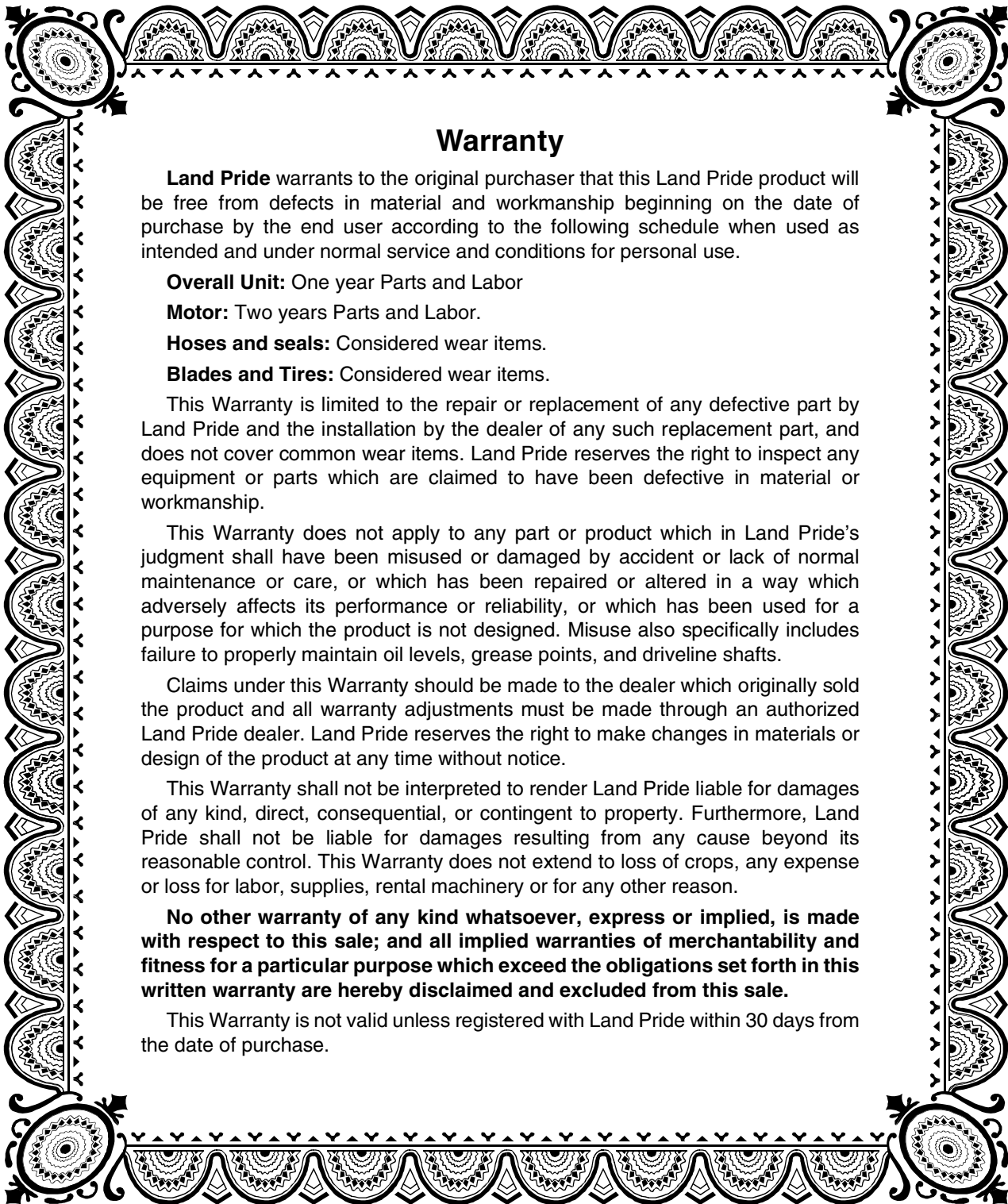

Warranty

Land Pride warrants to the original purchaser that this Land Pride product will be free from defects in material and workmanship beginning on the date of purchase by the end user according to the following schedule when used as intended and under normal service and conditions for personal use.

Overall Unit: One year Parts and Labor

Motor: Two years Parts and Labor.

Hoses and seals: Considered wear items.

Blades and Tires: Considered wear items.

This Warranty is limited to the repair or replacement of any defective part by Land Pride and the installation by the dealer of any such replacement part, and does not cover common wear items. Land Pride reserves the right to inspect any equipment or parts which are claimed to have been defective in material or workmanship.

This Warranty does not apply to any part or product which in Land Pride's judgment shall have been misused or damaged by accident or lack of normal maintenance or care, or which has been repaired or altered in a way which adversely affects its performance or reliability, or which has been used for a purpose for which the product is not designed. Misuse also specifically includes failure to properly maintain oil levels, grease points, and driveline shafts.

Claims under this Warranty should be made to the dealer which originally sold the product and all warranty adjustments must be made through an authorized Land Pride dealer. Land Pride reserves the right to make changes in materials or design of the product at any time without notice.

This Warranty shall not be interpreted to render Land Pride liable for damages of any kind, direct, consequential, or contingent to property. Furthermore, Land Pride shall not be liable for damages resulting from any cause beyond its reasonable control. This Warranty does not extend to loss of crops, any expense or loss for labor, supplies, rental machinery or for any other reason.

No other warranty of any kind whatsoever, express or implied, is made with respect to this sale; and all implied warranties of merchantability and fitness for a particular purpose which exceed the obligations set forth in this written warranty are hereby disclaimed and excluded from this sale.

This Warranty is not valid unless registered with Land Pride within 30 days from the date of purchase.

IMPORTANT: The Online Warranty Registration should be completed by the dealer at the time of purchase. This information is necessary to provide you with quality customer service.

Model Number _____

Serial Number _____

Legal Disclaimer

Kubota Corporation notes that specifications and technical information are subject to change without notice and Kubota does not represent or warrant that the information in this publication is completely accurate or current; however, Kubota used reasonable efforts to set forth and include accurate and up to date information in this publication. Kubota disclaims all representations and warranties, whether express or implied, including, but not limited to, warranties of merchantability and fitness for a particular purpose and Kubota shall not be liable for any damages, whether compensatory, direct, indirect, incidental, special, or consequential, arising out of or in connection with the use of this publication, or in the information therein.

The Product(s) described in this Publication are designed and manufactured only for the country in which they are initially wholesaled by Kubota. Kubota does not provide parts, warranty or service for any Product which is re-sold or retailed in any country other than the country for which the Product(s) were designed or manufactured.



KUBOTA TRACTOR CORPORATION
1000 Kubota Drive, Grapevine, TX 76051
Telephone: (817) 756-1171

Western Division: 1175 S. Guild Ave., Lodi, CA 95240
Telephone: (209) 334-9910

Midwest Division: 31700 W. 207th ST., Edgerton, KS 66021
Telephone: (913) 215-5915

Central Division: 14855 FAA Blvd., Fort Worth, TX 76155
Telephone: (817) 571-0900

Northern Division: 6300 at One Kubota Way, Groveport, OH 43125
Telephone: (614) 835-1100

Southeast Division: 1025 Northbrook Parkway, Suwanee, GA 30024
Telephone: (770) 995-8855
