

# Ditch Bank Rotary Cutter

DB2660 & DBM2660

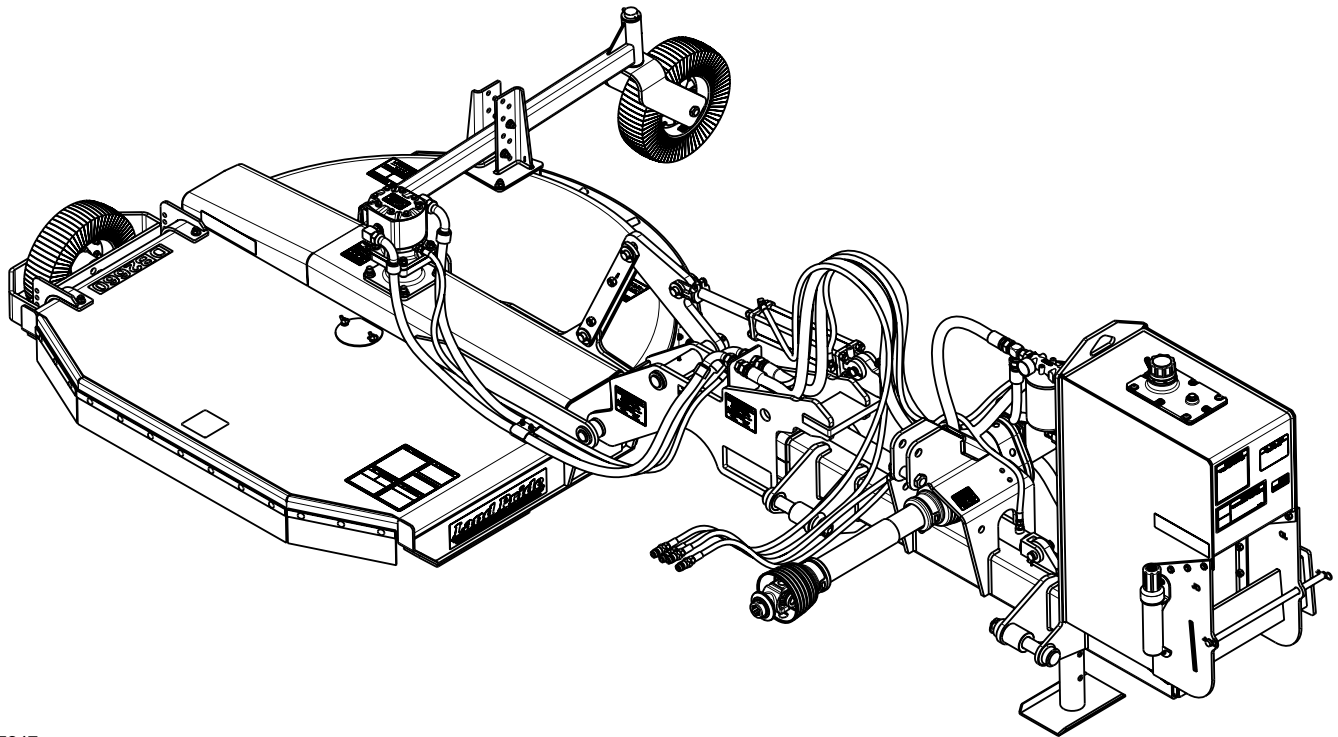

37247

## 316-317M Operator's Manual



Read the Operator's Manual entirely. When you see this symbol, the subsequent instructions and warnings are serious - follow without exception. Your life and the lives of others depend on it!

*Cover photo may show optional equipment not supplied with standard unit.*

*For an Operator's Manual and Decal Kit in French Language, please see your Land Pride dealer.*



## Machine Identification

Record your machine details in the log below. If you replace this manual, be sure to transfer this information to the new manual.

If you, or the dealer, have added Options not originally ordered with the machine, or removed Options that were originally ordered, the weights and measurements are no longer accurate for your machine. Update the record by adding the machine weight and measurements provided in the Specifications & Capacities Section of this manual with the Option(s) weight and measurements.

<b>Model Number</b>	
<b>Serial Number</b>	
<b>Machine Height</b>	
<b>Machine Length</b>	
<b>Machine Width</b>	
<b>Machine Weight</b>	
<b>Delivery Date</b>	
<b>First Operation</b>	
<b>Accessories</b>	<hr/> <hr/> <hr/>

## Dealer Contact Information

**Name:** \_\_\_\_\_

**Street:** \_\_\_\_\_

**City/State:** \_\_\_\_\_

**Telephone:** \_\_\_\_\_

**Email:** \_\_\_\_\_

 <b>California Proposition 65</b> <b>WARNING: Cancer and reproductive harm - <a href="http://www.P65Warnings.ca.gov">www.P65Warnings.ca.gov</a></b>
---

<b>Important Safety Information</b> .....	<b>1</b>	<b>Section 3: Hydraulic Plumbing</b> .....	<b>29</b>
Safety at All Times .....	1	Hydraulic Plumbing For Pump .....	29
Look For The Safety Alert Symbol .....	1	<b>Section 4: Adjustments</b> .....	<b>30</b>
Safety Labels .....	6	Turtle/Rabbit Flow Control .....	30
<b>Introduction</b> .....	<b>13</b>	Deck Leveling Front to Back .....	30
Application .....	13	Frame Leveling Left to Right .....	31
Using This Manual .....	13	Angle Problems With Driveline .....	31
Owner Assistance .....	13	Cutting Height Adjustment .....	32
Serial Number .....	13	Cutting Height Without Gauge Wheel .....	32
<b>Section 1: Assembly &amp; Set-up</b> .....	<b>14</b>	Cutting Height With Side Gauge Wheel .....	32
Tractor Requirements .....	14	Cutting Height With Rear Gauge Wheel .....	33
Protective Equipment Requirements .....	14	<b>Section 5: Operating Procedures</b> .....	<b>34</b>
Dealer Preparations .....	15	Startup Checklist .....	34
Unloading & Parking The Cutter .....	15	Safety Information .....	34
Preparing For Tractor Hook-up .....	15	Tractor Shut Down Procedure .....	35
Fill Hydraulic Reservoir With Fluid .....	15	Inspection of Tractor & Cutter .....	35
Check Hose Loops .....	15	Blade Operation Inspection .....	36
Rotate Deck Down .....	16	Hook-up Transport Safety Chain .....	37
Tractor Hook-up .....	18	Unhook Transport Safety Chain .....	37
Prepare Cutter for Hook-up .....	18	Transporting .....	38
3-Point Hook-up to Cat. II Standard Hitch .....	18	Blade Engagement & Disengagement .....	38
Upper Center Bushing Placement .....	19	Field Set-up & Operation .....	39
Lower Hitch Pin Set-up For Cat. II Quick Hitch .....	19	Unhook Ditch Bank Cutter .....	40
Lower Hitch Pin Set-up For Cat. III Quick Hitch .....	19	Initial Preparation .....	40
Driveline Installation (Optional) .....	20	Unhook Hydraulic Hoses .....	40
Driveline Hook-up (Optional) .....	20	Unhook Driveline Option .....	40
Check Driveline Collapsible Length .....	21	Unhook Speed Increaser/Pump Option .....	40
Check Driveline Maximum Length .....	22	Unhook 3-Point Hitch Option .....	40
Check Driveline Interference .....	22	Unhook Quick Hitch Option .....	40
Speed Increaser Hook-up (Optional) .....	23	Relocate SMV Sign .....	40
Purge Hydraulic Cylinders .....	23	<b>Section 6: Maintenance &amp; Lubrication</b> .....	<b>41</b>
<b>Section 2: Options &amp; Accessories Set-up</b> ..	<b>24</b>	General Maintenance Information .....	41
Tailwheel (Optional) .....	24	Hydraulic System .....	41
Side Gauge Wheel (Optional) .....	24	Skid Shoes .....	41
Weight Hanger Assembly (Optional) .....	24	Cutter Blade Maintenance .....	42
Bolt-on Weight Hangers .....	25	Long Term Storage .....	43
Optional Front Guard Assemblies .....	26	Lubrication Points .....	44
Front Rubber Guard .....	26	<b>Section 7: Specifications &amp; Capacities</b> .....	<b>50</b>
Front Single or Double Chain Guard .....	26	<b>Section 8: Features and Benefits</b> .....	<b>52</b>
Optional Rear Guard Assemblies .....	27	<b>Section 9: Troubleshooting</b> .....	<b>53</b>
Rear Rubber Guard .....	27	<b>Section 10: Torque Values Chart</b> .....	<b>54</b>
Rear Single or Double Chain Guard .....	27	<b>Section 11: Warranty</b> .....	<b>55</b>
Slow Moving Vehicle Sign (Accessory) .....	27		
Protective Shield (Accessory) .....	28		



© Copyright 2019 All rights Reserved

Land Pride provides this publication “as is” without warranty of any kind, either expressed or implied. While every precaution has been taken in the preparation of this manual, Land Pride assumes no responsibility for errors or omissions. Neither is any liability assumed for damages resulting from the use of the information contained herein. Land Pride reserves the right to revise and improve its products as it sees fit. This publication describes the state of this product at the time of its publication, and may not reflect the product in the future.

Land Pride is a registered trademark.

All other brands and product names are trademarks or registered trademarks of their respective holders.

Printed in the United States of America.

See previous page for Table of contents.



### ***Parts Manual QR Locator***

The QR (Quick Reference) code on the cover and to the left will take you to the Parts Manual for this equipment. Download the appropriate App on your smart phone, open the App, point your phone on the QR code and take a picture.



### ***Dealer QR Locator***

The QR code on the left will link you to available dealers for Land Pride products. Refer to Parts Manual QR Locator on this page for detailed instructions.



These are common practices that may or may not be applicable to the products described in this manual.

### Safety at All Times

Careful operation is your best insurance against an accident.

All operators, no matter how much experience they may have, should carefully read this manual and other related manuals before operating the power machine and this implement.

It is the owner's obligation to instruct all operators in safe operation.

- ▲ Thoroughly read and understand the "Safety Label" section, read all instructions noted on them.
- ▲ Do not operate the equipment while under the influence of drugs or alcohol as they impair the ability to safely and properly operate the equipment.
- ▲ The operator should be familiar with all functions of the tractor and attached implement, and be able to handle emergencies quickly.
- ▲ Make sure all guards and shields are in place and secured before operating implement.
- ▲ Keep all bystanders away from equipment and work area.
- ▲ Start tractor from the driver's seat with hydraulic controls in neutral.
- ▲ Operate tractor and controls from the driver's seat only.
- ▲ Never dismount from a moving tractor or leave tractor unattended with engine running.
- ▲ Do not allow anyone to stand between tractor and implement while backing up to implement.
- ▲ Keep hands, feet, and clothing away from power-driven parts.
- ▲ While transporting and operating equipment, watch out for objects overhead and along side such as fences, trees, buildings, wires, etc.
- ▲ Do not turn tractor so tight as to cause hitched implement to ride up on the tractor's rear wheel.
- ▲ Store implement in an area where children normally do not play.



### Look For The Safety Alert Symbol

The SAFETY ALERT SYMBOL indicates there is a potential hazard to personal safety involved and extra safety precaution must be taken. When you see this symbol, be alert and carefully read the message that follows it. In addition to design and configuration of equipment, hazard control, and accident prevention are dependent upon the awareness, concern, prudence, and proper training of personnel involved in the operation, transport, maintenance, and storage of equipment.

#### Be Aware of Signal Words

A signal word designates a degree or level of hazard seriousness. The signal words are:

##### DANGER

Indicates a hazardous situation that, if not avoided, will result in death or serious injury.

##### WARNING

Indicates a hazardous situation that, if not avoided, could result in death or serious injury.

##### CAUTION

Indicates a hazardous situation that, if not avoided, may result in minor or moderate injury.

### Safety Precautions for Children

**Tragedy can occur if the operator is not alert to the presence of children, Children generally are attracted to implements and their work.**

- ▲ Never assume children will remain where you last saw them.
- ▲ Keep children out of the work area and under the watchful eye of a responsible adult.
- ▲ Be alert and shut the implement and tractor down if children enter the work area.
- ▲ Never carry children on the tractor or implement. There is not a safe place for them to ride. They may fall off and be run over or interfere with the control of the power machine.
- ▲ Never allow children to operate the power machine, even under adult supervision.
- ▲ Never allow children to play on the power machine or implement.
- ▲ Use extra caution when backing up. Before the tractor starts to move, look down and behind to make sure the area is clear.

### Tractor Shutdown & Storage

- ▲ If engaged, disengage power take-off.
- ▲ Park on solid, level ground and lower implement to ground or onto support blocks.
- ▲ Put tractor in park or set park brake, turn off engine, and remove switch key to prevent unauthorized starting.
- ▲ Relieve all hydraulic pressure to auxiliary hydraulic lines.
- ▲ Wait for all components to stop before leaving operator's seat.
- ▲ Use steps, grab-handles and skid-resistant surfaces when getting on and off the tractor.
- ▲ Detach and store implement in an area where children normally do not play. Secure implement using blocks and supports.

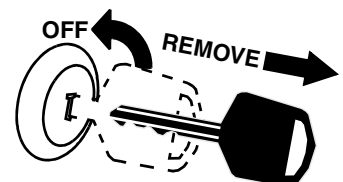

These are common practices that may or may not be applicable to the products described in this manual.

### Use A Safety Chain

- ▲ A safety chain will help control drawn machinery should it separate from the tractor drawbar.
- ▲ Use a chain with the strength rating equal to or greater than the gross weight of the towed implement.
- ▲ Attach the chain to the tractor drawbar support or other specified anchor location. Allow only enough slack in the chain to permit turning.
- ▲ Always hitch the implement to the machine towing it. Do not use the safety chain tow the implement.

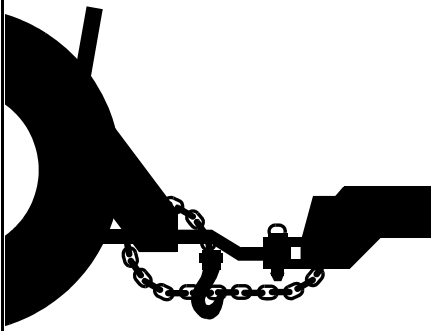

### Transport Safely

- ▲ Comply with state and local laws.
- ▲ Use towing vehicle and trailer of adequate size and capacity. Secure equipment towed on a trailer with tie downs and chains.
- ▲ Sudden braking can cause a towed trailer to swerve and upset. Reduce speed if towed trailer is not equipped with brakes.
- ▲ Avoid contact with any over head utility lines or electrically charged conductors.
- ▲ Always drive with load on end of loader arms low to the ground.
- ▲ Always drive straight up and down steep inclines with heavy end of a tractor with loader attachment on the "uphill" side.
- ▲ Engage park brake when stopped on an incline.
- ▲ Maximum transport speed for an attached equipment is 20 mph. **DO NOT EXCEED.** Never travel at a speed which does not allow adequate control of steering and stopping. Some rough terrains require a slower speed.
- ▲ As a guideline, use the following maximum speed weight ratios for attached equipment:
  - 20 mph** when weight of attached equipment is less than or equal to the weight of machine towing the equipment.
  - 10 mph** when weight of attached equipment exceeds weight of machine towing equipment but not more than double the weight.
- ▲ **IMPORTANT:** Do not tow a load that is more than double the weight of the vehicle towing the load.



### Tire Safety

- ▲ Tire changing can be dangerous and must be performed by trained personnel using the correct tools and equipment.
- ▲ Always maintain correct tire pressure. Do not inflate tires above recommended pressures shown in the Operator's Manual.
- ▲ When inflating tires, use a clip-on chuck and extension hose long enough to allow you to stand to one side and NOT in front of or over the tire assembly. Use a safety cage if available.
- ▲ Securely support the implement when changing a wheel.
- ▲ When removing and installing wheels, use wheel handling equipment adequate for the weight involved.
- ▲ Make sure wheel bolts have been tightened to the specified torque.



### Practice Safe Maintenance

- ▲ Understand procedure before doing work. Refer to the Operator's Manual for additional information.
- ▲ Work on a level surface in a clean dry area that is well-lit.
- ▲ Use properly grounded electrical outlets and tools.
- ▲ Use correct tools and equipment for the job that are in good condition.
- ▲ Lower implement to the ground and follow all shutdown procedures before leaving the operator's seat to perform maintenance.
- ▲ Allow equipment to cool before working on it.
- ▲ Disconnect battery ground cable (-) before servicing or adjusting electrical systems or before welding on implement.
- ▲ Do not grease or oil implement while it is in operation.
- ▲ Inspect all parts. Make certain parts are in good condition & installed properly.
- ▲ Replace parts on this implement with genuine Land Pride parts only. Do not alter this implement in a way which will adversely affect its performance.
- ▲ Remove buildup of grease, oil, or debris.
- ▲ Remove all tools and unused parts from equipment before operation.



These are common practices that may or may not be applicable to the products described in this manual.

**Prepare for Emergencies**

- ▲ Be prepared if a fire starts.
- ▲ Keep a first aid kit and fire extinguisher handy.
- ▲ Keep emergency numbers for doctor, ambulance, hospital, and fire department near phone.

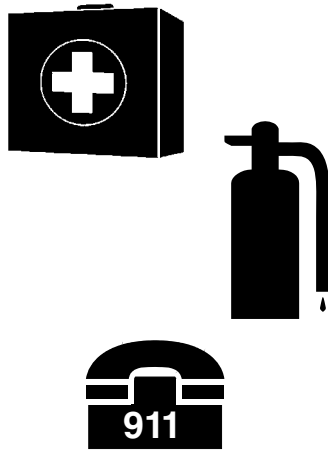

**Wear Protective Equipment**

- ▲ Wear protective clothing and equipment appropriate for the job such as safety shoes, safety glasses, hard hat, and ear plugs.
- ▲ Clothing should fit snug without fringes and pull strings to avoid entanglement with moving parts.
- ▲ Prolonged exposure to loud noise can cause hearing impairment or hearing loss. Wear suitable hearing protection such as earmuffs or earplugs.
- ▲ Operating equipment safely requires the operator's full attention. Avoid wearing headphones while operating equipment.



**Avoid High Pressure Fluids Hazard**

- ▲ Escaping fluid under pressure can penetrate the skin causing serious injury.
- ▲ Before disconnecting hydraulic lines or performing work on the hydraulic system, be sure to release all residual pressure.
- ▲ Make sure all hydraulic fluid connections are tight and all hydraulic hoses and lines are in good condition before applying pressure to the system.
- ▲ Use a piece of paper or cardboard, NOT BODY PARTS, to check for suspected leaks.
- ▲ Wear protective gloves and safety glasses or goggles when working with hydraulic systems.
- ▲ **DO NOT DELAY.** If an accident occurs, see a doctor familiar with this type of injury immediately. Any fluid injected into the skin or eyes must be treated within a few hours or gangrene may result.



**Use Safety Lights and Devices**

- ▲ Slow moving tractors, and self-propelled equipment can create a hazard when driven on public roads. They are difficult to see, especially at night. Use the Slow Moving Vehicle (SMV) sign when on public roads.
- ▲ Flashing warning lights and turn signals are recommended whenever driving on public roads.

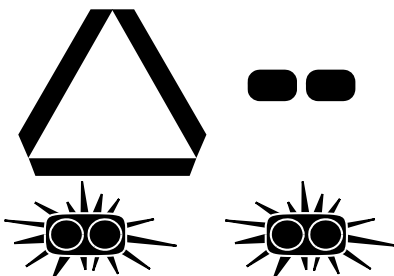

**Use Seat Belt and ROPS**

- ▲ Land Pride recommends the use of a CAB or roll-over-protective-structures (ROPS) and seat belt in almost all power machines. Combination of a CAB or ROPS and seat belt will reduce the risk of serious injury or death if the power machine should be upset.
- ▲ If ROPS is in the locked-up position, fasten seat belt snugly and securely to help protect against serious injury or death from falling and machine overturn.

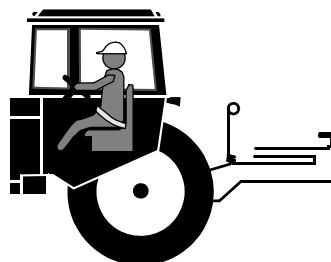

**Keep Riders Off Machinery**

- ▲ Never carry riders or use tractor to lift or transport individuals.
- ▲ There is not a safe place for a person to ride.
- ▲ Riders obstruct operator's view and interfere with the control of the power machine.
- ▲ Riders can be struck by objects or thrown from the equipment.

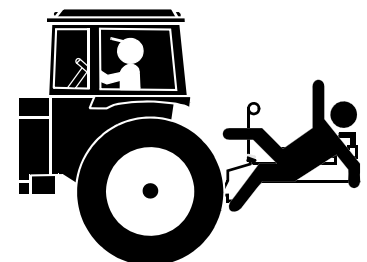

These are common practices that may or may not be applicable to the products described in this manual.

### Avoid crystalline Silica (quartz) Dust

Because crystalline silica is a basic component of sand and granite, many activities at construction sites produce dust containing crystalline silica. Trenching, sawing, and boring of material containing crystalline silica can produce dust containing crystalline silica particles. This dust can cause serious injury to the lungs (silicosis).

There are guidelines which should be followed if crystalline silica (quartz) is present in the dust.

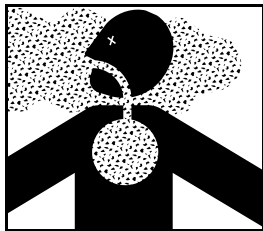

- ▲ Be aware of and follow OSHA (or other local, State, or Federal) guidelines for exposure to airborne crystalline silica.
- ▲ Know the work operations where exposure to crystalline silica may occur.
- ▲ Participate in air monitoring or training programs offered by the employer.
- ▲ Be aware of and use optional equipment controls such as water sprays, local exhaust ventilation, and enclosed cabs with positive pressure air conditioning if the machine has such equipment. Otherwise respirators shall be worn.
- ▲ Where respirators are required, wear a respirator approved for protection against crystalline silica containing dust. Do not alter respirator in any way. Workers who use tight-fitting respirators can not have beards/mustaches which interfere with the respirator seal to the face.
- ▲ If possible, change into disposable or washable work clothes at the work site; shower and change into clean clothing before leaving the work site.
- ▲ Do not eat, drink, use tobacco products, or apply cosmetics in areas where there is dust containing crystalline silica.
- ▲ Store food, drink, and personal belongings away from the work area.
- ▲ Wash hands and face before eating, drinking, smoking, or applying cosmetics after leaving the exposure area.

### Handle Chemicals Properly

- ▲ Protective clothing should be worn.
- ▲ Handle all chemicals with care.
- ▲ Follow instructions on container label.
- ▲ Agricultural chemicals can be dangerous. Improper use can seriously injure persons, animals, plants, soil, and property.
- ▲ Inhaling smoke from any type of chemical fire can be a serious health hazard.
- ▲ Store or dispose of unused chemicals as specified by the chemical manufacturer.



### Dig Safe - Avoid Underground Utilities

- ▲ **USA: Call 811**  
**CAN: [digsafecanada.ca](http://digsafecanada.ca)**  
Always contact your local utility companies (electrical, telephone, gas, water, sewer, and others) before digging so that they may mark the location of any underground services in the area.
- ▲ Be sure to ask how close you can work to the marks they positioned.



This page left blank intentionally.

### Safety Labels

Your Ditch Bank Cutter comes equipped with all safety labels in place. They were designed to help you safely operate your implement. Read and follow their directions.

1. Keep all safety labels clean and legible.
2. Refer to this section for proper label placement. Replace all damaged or missing labels. Order new labels from your nearest Land Pride dealer. To find your nearest dealer, visit our dealer locator at [www.landpride.com](http://www.landpride.com).
3. Some new equipment installed during repair requires safety labels to be affixed to the replaced component as

specified by Land Pride. When ordering new components make sure the correct safety labels are included in the request.

4. Refer to this section for proper label placement. To install new labels:
  - a. Clean area where label is to be placed.
  - b. Spray soapy water on the surface where the label is to be placed.
  - c. Peel backing from label. Press firmly onto the surface.
  - d. Squeeze out air bubbles with the edge of a credit card or with a similar type straight edge.

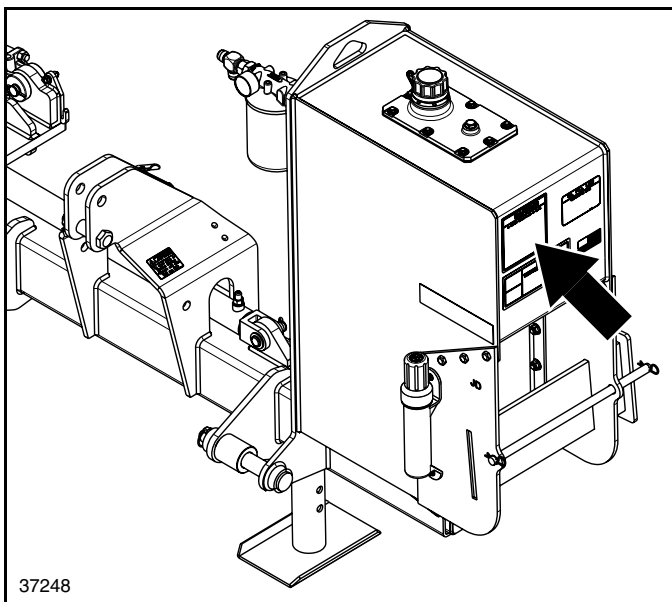

## WARNING

To prevent serious injury or death:

- \* Read and understand Operator's Manual before using. Review annually.
- \* Do not permit riders on the tractor or mower. Never carry children on tractor seat.
- \* Do not allow children to operate mower.
- \* Operate only with guards installed and in good condition.
- \* Keep away from moving parts.
- \* Operate only with tractor equipped with RDPS and seatbelts.
- \* Before mowing, clear debris from mowing area.
- \* Do not operate in the raised position.
- \* Stop engine, set brake and wait for all moving parts to stop before dismounting.
- \* Support mower securely before working beneath unit.
- \* Transport with clean reflectors, SMV and working lights as required by federal, state, and local laws.

Si no lee ingles, pida ayuda a alguien que si lo lea para que le traduzca las medidas de seguridad.

818-554C

### 818-554C

Caution: General Safety Information

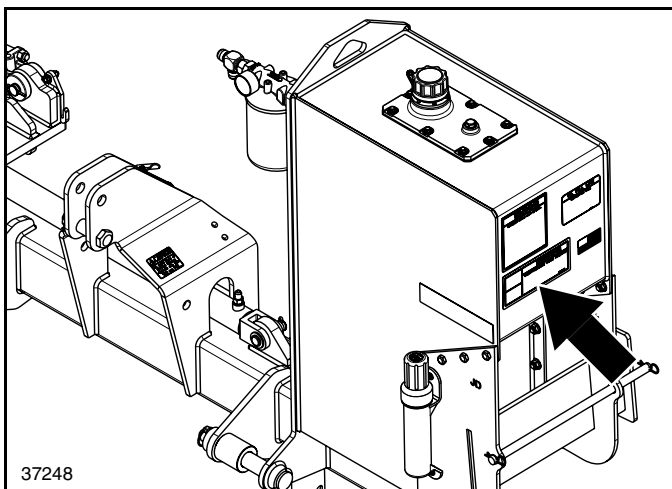

## WARNING

HIGH-PRESSURE FLUID HAZARD

To prevent serious injury or death

- Relieve pressure on hydraulic system before servicing or disconnecting hoses.
- Wear proper hand and eye protection when searching for leaks. Do not use fingers to check for leaks; use wood or cardboard.
- Keep all components in good repair.

15

### 818-831C

Warning: High Pressure Fluid Hazard

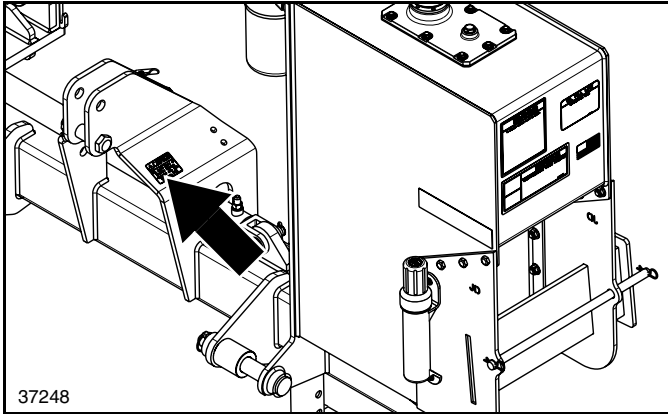

**818-130C**

Warning: Use with 540 rpm power take-off only

**818-240C**

Warning: Use with 1000 rpm power take-off only

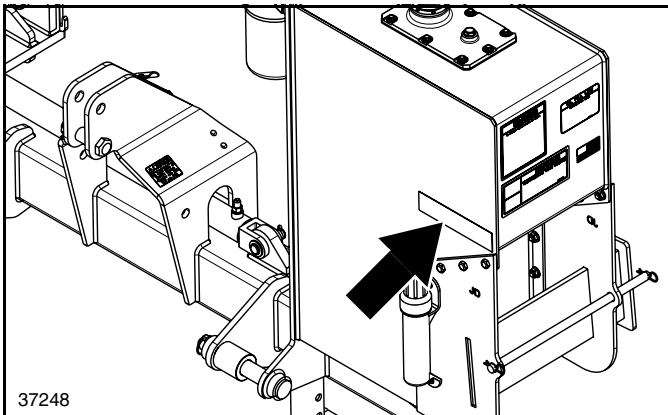

**838-615C**

2" x 9" Amber Reflector

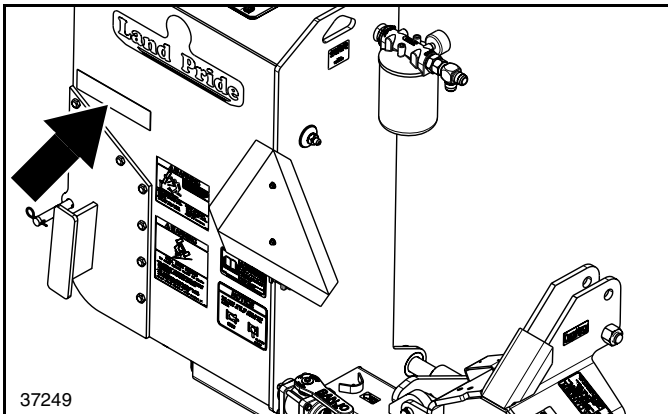

**838-614C**

2" x 9" Red Reflector

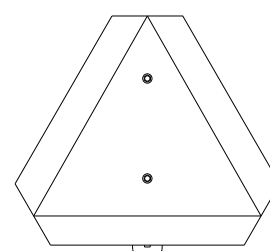
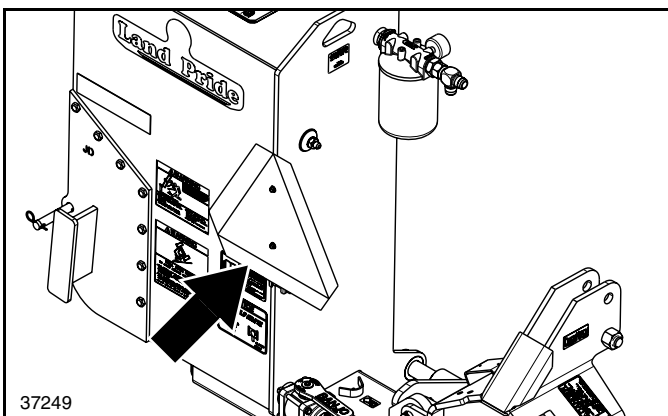

**316-362S**

Socket mounted Slow Moving Vehicle Sign  
Offered as an Accessory. See "Slow Moving Vehicle Sign (Accessory)" on page 27.

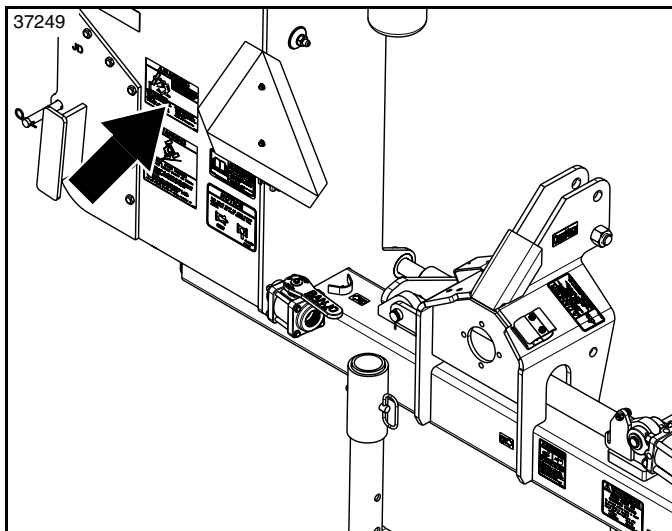

**818-390C**

Warning: Thrown Object Hazard

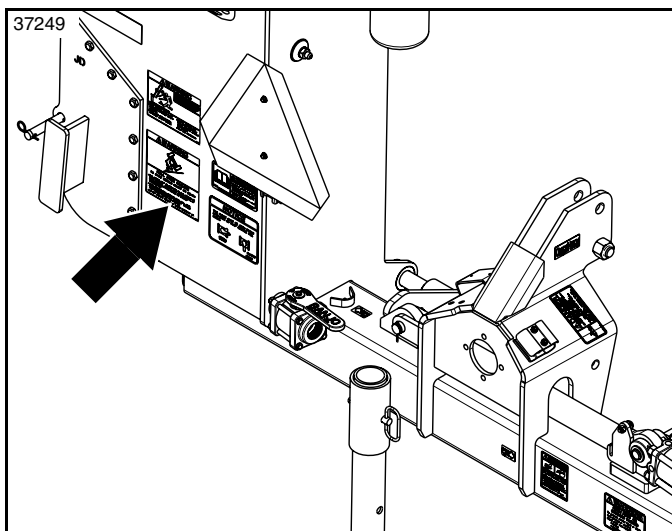

**818-391C**

Warning: Tractor Roll Over Hazard

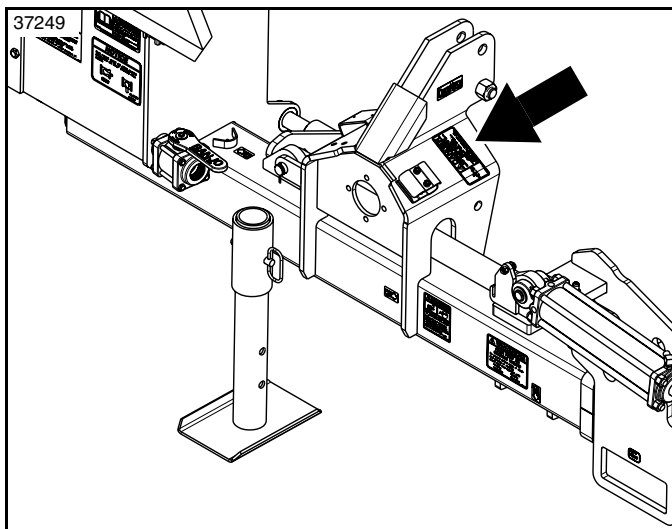

**818-142C**

Danger: Rotating Driveline Hazard



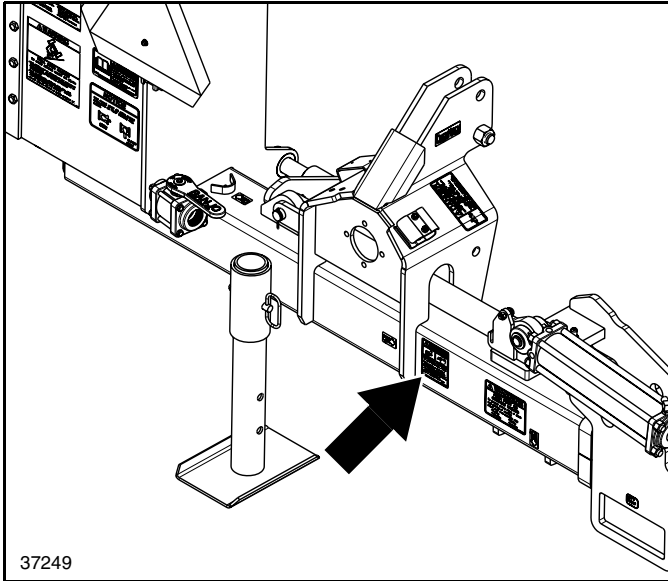

**818-339C**

Warning: High Pressure Fluid Hazard

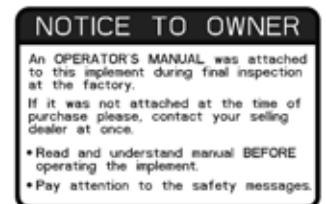
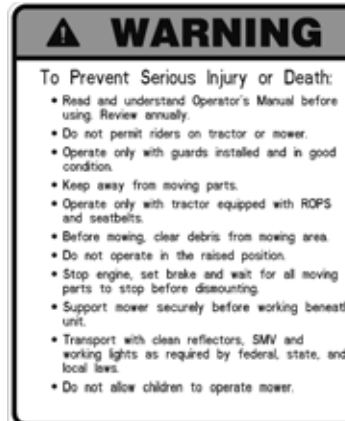
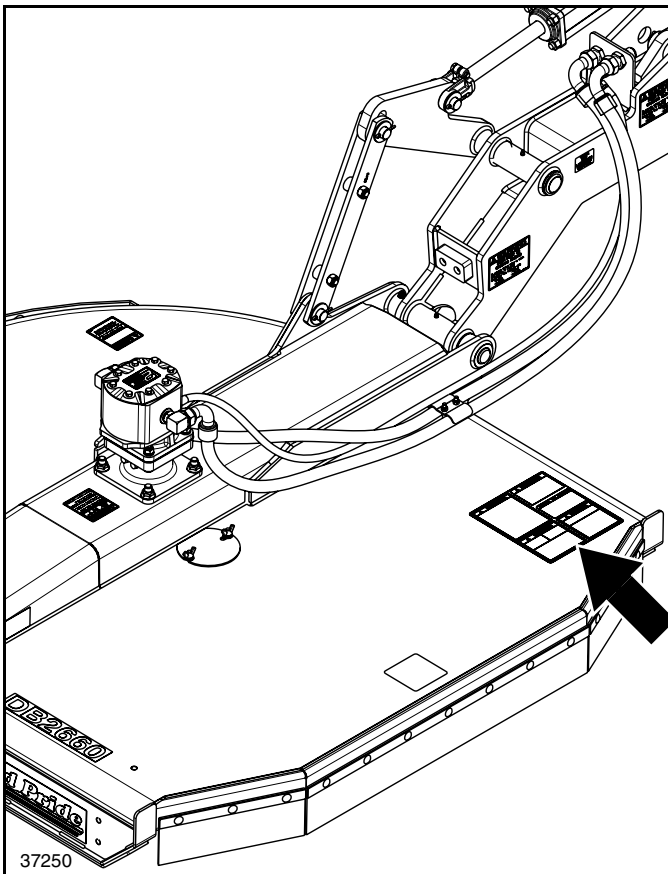

**818-830C**

Warning/Danger/Notice: Combination Safety Decal

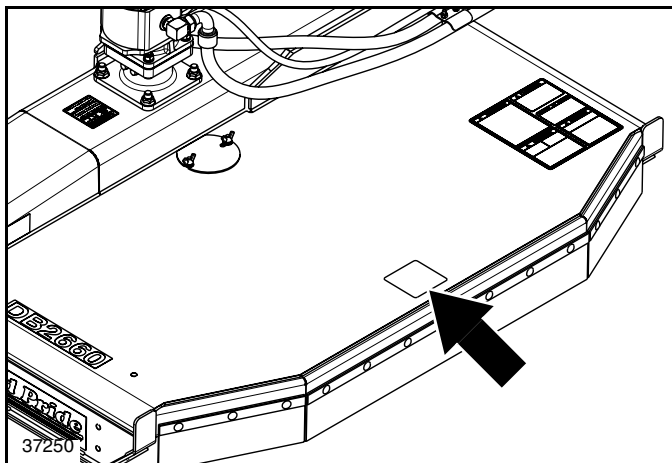

**818-555C**

Danger: Rotating Blades Keep Away

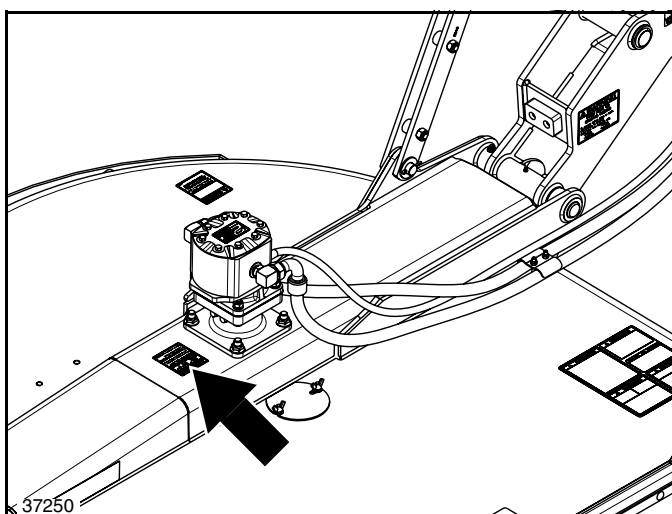

**818-339C**

Warning: High Pressure Fluid Hazard

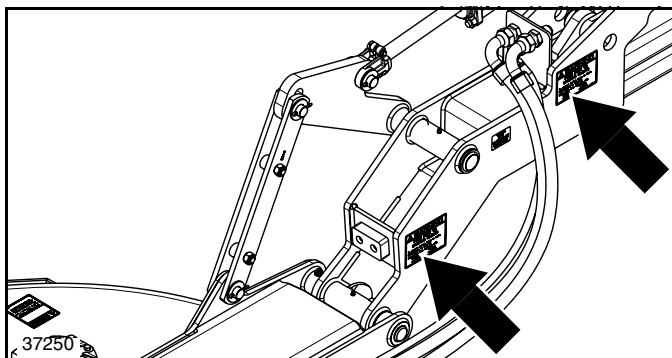

**818-045C**

Warning: Pinch Point Hazard (4-Places)

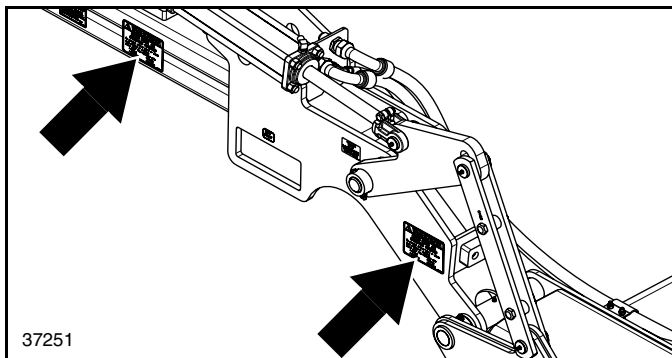

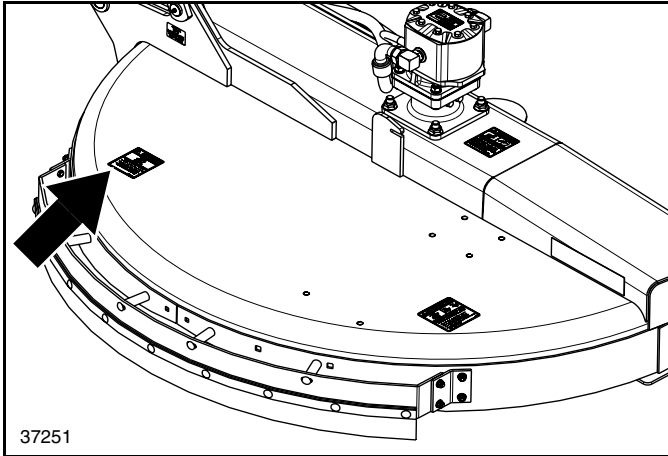

**818-556C**

Danger: Thrown Object Hazard

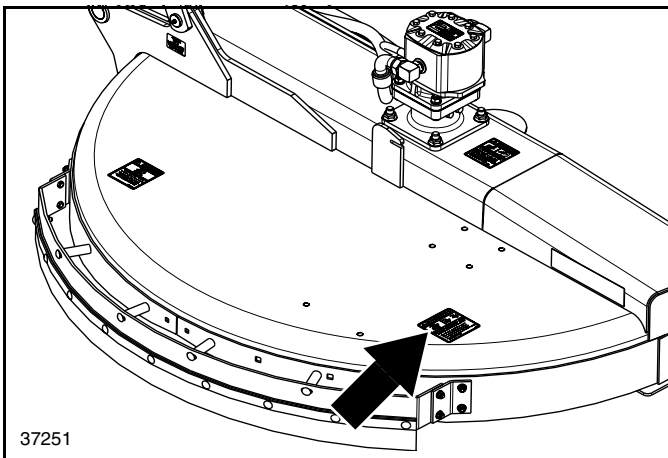

**818-555C**

Danger: Rotating Blades Keep Away



**838-614C**

2" x 9" Red Reflector

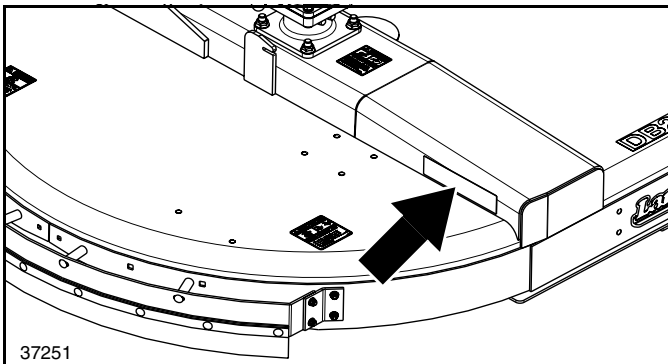

**838-615C**

2" x 9" Amber Reflector

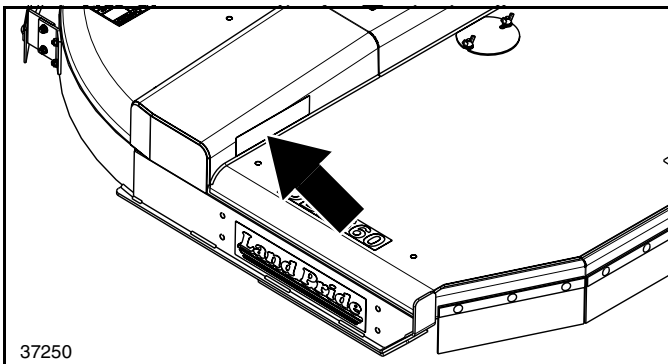

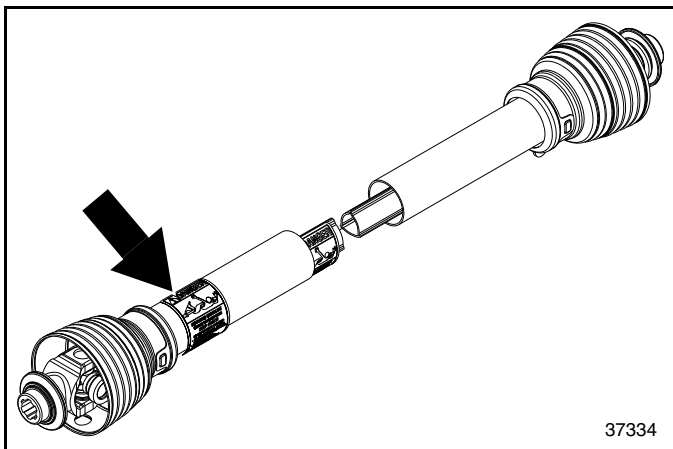

**818-552C**

Danger: Rotating Driveline

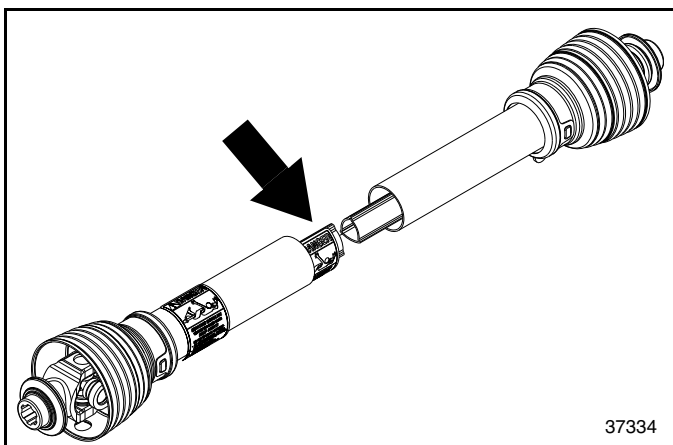

**818-564C**

Danger: Guard Missing

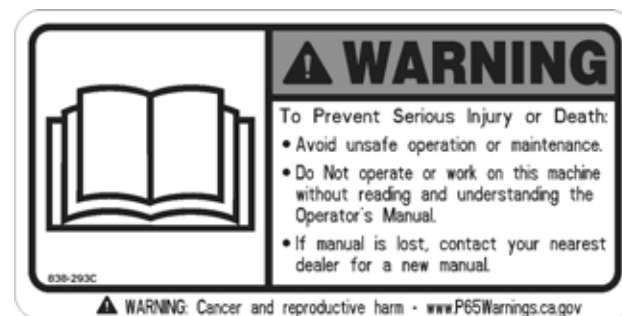
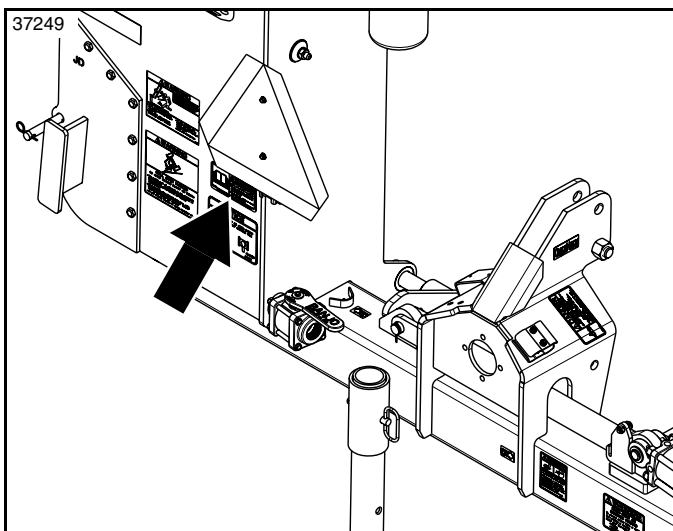

**838-293C**

Warning: Read Manual

## Introduction

Land Pride welcomes you to the growing family of new product owners. This Ditch Bank Cutter has been designed with care and built by skilled workers using quality materials. Proper assembly, maintenance, and safe operating practices will help you get years of satisfactory use from this implement.

## Application

The DB2660 Hydraulic Ditch Bank Cutter is designed and built by Land Pride to provide excellent cutting performance on ditch banks and other sloping areas adjacent to right-of-ways, lakes, ponds, and streams. They are designed to work equally as well in and around areas of restricted access such as guardrails, low overhanging branches, tree limbs, and hedges. These units perform extremely well in tall grass cutting applications and will easily cut through standing brush up to one inch in diameter. Optional gauge wheels are also available for customers who want to maintain a constant cutting height with minimal control lever manipulation.

The DB(M)2660 cutter is designed for tractors in the 75 minimum hp range with a minimum weight of 7,000 lbs. This cutter will fit Cat. II 3-point hitches, or it will fit Cat. II or Cat. III quick hitches.

The hydraulic drive requires 540 or 1000 rpm input power take-off speed. Two duplex hydraulic outlets are required on the tractor to operate the cutter's extension arm cylinder and deck pivot cylinder.

See “**Specifications & Capacities**” on page 50 and “**Features & Benefits**” on page 52 for additional information and performance enhancing options.

## Using This Manual

- This Operator's Manual is designed to help familiarize you with safety, assembly, operation, adjustments, troubleshooting, and maintenance. Read this manual and follow the recommendations to help ensure safe and efficient operation.
- The information contained within this manual was current at the time of printing. Some parts may change slightly to assure you of the best performance.
- To order a new Operator's or Parts Manual, contact your authorized dealer. Manuals can also be downloaded, free-of-charge, from our website at [www.landpride.com](http://www.landpride.com)

## Terminology

“Right” or “Left” as used in this manual is determined by facing forward in the direction the machine will operate while in use unless otherwise stated.

## Definitions

**IMPORTANT:** A special point of information related to the following topic. Land Pride's intention is this information must be read & noted before continuing.

**NOTE:** A special point of information that the operator should be aware of before continuing.

## Owner Assistance

The dealer should complete the Online Warranty Registration at the time of purchase. This information is necessary to provide you with quality customer service.

The parts on your Ditch Bank Cutter have been specially designed by Land Pride and should only be replaced with genuine Land Pride parts. Contact a Land Pride dealer if customer service or repair parts are required. Your Land Pride dealer has trained personnel, repair parts, and equipment needed to service the implement.

## Serial Number

For quick reference and prompt service, record model and serial number on the inside cover page and again on the warranty page. Always provide model number and serial number when ordering parts and in all correspondences with your Land Pride dealer. For location of your serial number plate, see Figure 1.

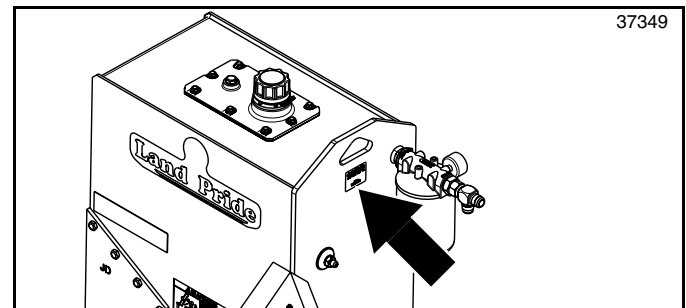

Serial Number Plate Location  
Figure 1

## Further Assistance

Your dealer wants you to be satisfied with your new Ditch Bank Cutter. If for any reason you do not understand any part of this manual or are not satisfied with the service received, the following actions are suggested:

1. Discuss any problems you have with your implement with your dealership service personnel so they can address the problem.
2. If you are still not satisfied, seek out the owner or general manager of the dealership, explain the question/problem, and request assistance.
3. For further assistance write to:

**Land Pride Service Department**  
1525 East North Street  
P.O. Box 5060  
Salina, Ks. 67402-5060

E-mail address  
[lp servicedept@landpride.com](mailto:lp servicedept@landpride.com)



Section 1: Assembly & Set-up

### Tractor Requirements

Tractor horsepower must be capable of controlling the Ditch Bank Cutter under all operating conditions. Smaller tractors must not be used.

- Horsepower rating . . . . . 75 minimum hp
- 3-Point hitch . . . Cat. II std., Cat II or Cat. III Quick hitch  
See also “**3-Point Hitch**” below.
- Rear power take-off speed: . . . . . 540 or 1000 rpm
- Power take-off shaft type: . . . . .  
540 rpm. . . . . 1 3/8”-6 spline  
1000 rpm. . . . . 1 3/8”-21 spline
- Number of duplex outlets  
Extension arm cylinder . . . . . 1  
Deck pivot cylinder . . . . . 1  
See also “**Hydraulic Outlets**” below.
- Tractor Weight  
Minimum weight . . . . . 7,000 lbs  
See also “**Weight**” below.
- Minimum outside rear wheel base . . . . . 74”  
See also “**Wheel Base**” on this page.

### 3-Point Hitch

A 3-point Category II or Category III hitch is required. The Cat. II hitch is quick hitch adaptable. A quick hitch must be used with Cat. III hitch. The lower 3-point arms of the 3-point hitch must be stabilized to prevent side-to-side movement. Most tractors have sway blocks or adjustable chains for this purpose.

### Hydraulic Outlets

Control lever for deck pivot cylinder must be capable of infinite variable flow control (turtle/rabbit control) with self-cancel detent without gauge wheels and float detent with gauge wheels.

### Weight

#### **WARNING**

To avoid serious injury or death:

Lightweight tractors with rear attached implements may need weights added to the front to maintain steering control. Consult your tractor Operator’s Manual to determine proper weight requirements and maximum weight limitations.

**IMPORTANT:** An extended extension arm will pull the tractor’s front to the right. When necessary, add weight to the tractor front to stabilize it. Consult your tractor’s manual for allowable added weights.

**IMPORTANT:** The tractor’s right rear wheel should be pressurized to the manufactures highest recommended air pressure.

**Minimum:** Tractor weight must be sufficient to control the Ditch Bank Cutter under all operating conditions. Tractors that do not meet the absolute minimum weight listed above must not be used.

It is best to add auxiliary weights to the left rear tractor wheel. In addition, up to eight 100 lb. suitcase type weights can be added to the optional weight hanger on the hydraulic reservoir. However, adding weights to the reservoir can lighten the tractor’s front. Additional weights may need to be added to the front of the tractor.

### Wheel Base

Refer to Figure 1-1:

Rear wheel base must meet minimum requirements when measured from outside face to outside face of rear tractor tires. Smaller wheel bases must not be used. Tractors equipped with dual wheels will need the outside right rear wheel removed.

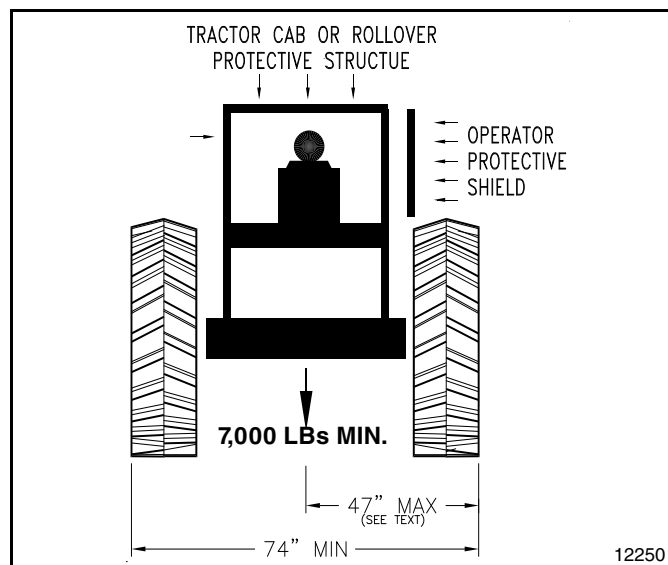

Minimum Tractor Wheel Base and Weight  
Figure 1-1

### Protective Equipment Requirements

Refer to Figure 1-1:

#### **DANGER**

To avoid serious injury or death:

Always use a tractor equipped with protective equipment designed to shield operator from thrown objects and protect operator from tractor rollover. Always fasten seat belt snugly and securely when operating the Ditch Bank Cutter. Operating the Ditch Bank Cutter without proper protective equipment can result in bodily injury or death.

The tractor **MUST** be equipped with protective equipment designed to shield the operator from thrown objects and tractor rollover. An enclosed tractor cab with a Roll Over Protective Structure (ROPS) may qualify. See the tractor’s manual to determine if it qualifies.

Tractors with only a ROPS must have a protective shield added to the right-hand fender. A universal operator protective shield is available from Land Pride. Refer to “**Protective Shield (Accessory)**” on page 28 for additional information and installation.

## Section 1: Assembly & Set-up

It is also recommended that a protective shield or screen be added to the right-hand side of the tractor engine cowling and radiator. This will help protect the tractor's finish and radiator against thrown objects.

### Dealer Preparations

This cutter has been assembled at the factory. However, some preparations will be necessary to attach the cutter to the customer's tractor.

- Make certain the intended tractor conforms to the "Tractor Requirements" on page 14.
- Review and check off "Pre-Assembly Checklist" below before proceeding.

### Pre-Assembly Checklist

✓	Check
<input type="checkbox"/>	Cat. II & Cat. III quick hitch hook-ups will use upper center bolt and bushing supplied with cutter. An upper hitch pin must be supplied by customer when making a 3-point Cat II hook-up. If customer does not have a hitch pin, one can be purchased from Land Pride. See hitch pin part number and description below. <b>805-079C - Upper Hitch Pin Cat II (1" dia. x 3 3/8" usable)</b>
<input type="checkbox"/>	Before operating this unit, 80-90 EP Gear Lube must be added to the speed increaser as indicated in the "Maintenance & Lubrication" section for "Speed Increaser" on page 46 of this manual.
<input type="checkbox"/>	35 Gallons of hydraulic fluid is needed for the hydraulic reservoir. Use high quality mineral based hydraulic fluid such as Mobilfluid 424 with a viscosity rating of 10W-30.
<input type="checkbox"/>	Additional hydraulic fluid (approx 2 gallons) may be needed for the tractor reservoir.
<input type="checkbox"/>	Miscellaneous assembly tools: hammer, tape measure, assortment of wrenches and sockets, and spirit level.
<input type="checkbox"/>	Have a forklift or hoist with properly sized chains and safety stands on hand capable of lifting 2500 lbs.
<input type="checkbox"/>	Auxiliary tractor weights (depending on tractor size). See "Tractor Requirements" on page 14.
<input type="checkbox"/>	A minimum of two people available during assembly.
<input type="checkbox"/>	Be sure parts get used in the correct location. Use Parts Manual to identify location of pins, bolts, and other parts that you are unsure of their location. By double checking, you will lessen the chance of using a bolt or pin incorrectly that may be needed later.
<input type="checkbox"/>	Make sure working parts move freely, bolts are tight & cotter pins are spread.
<input type="checkbox"/>	Make sure all grease fittings are in place and lubricated.
<input type="checkbox"/>	Make sure all safety decals are legible and undamaged. Red and amber reflectors are correctly located and visible when machine is in transport position.
<input type="checkbox"/>	Driveline and loose parts bag/box shipped with the cutter are present.

### Unloading & Parking The Cutter

**Refer to Figure 1-2 on page 16:**

1. Check transport safety chain (#1). It must be secured in deck hook (#6) with zip tie (#19) before moving cutter or working around the unit.

2. Use a fork lift capable of lifting 2500 lbs to lift the cutter. Insert right fork through slot (#4) in extension arm and left fork under mainframe (#3) as illustrated with arrows.
3. Lift cutter from the shipping trailer and transport it to your work area or storage location.
4. Park fork lift with Ditch Bank Cutter on level hard ground. Lower cutter until supported on parking stand (#2) and shipping block (#16).
5. Remove fork lift from under the cutter if storing cutter without setting it up for tractor hook-up. Do not remove fork lift if hooking-up cutter to a tractor.

### Preparing For Tractor Hook-up

The Ditch Bank Cutter is shipped with the deck folded up and hydraulic reservoir empty of fluid. **The reservoir will need to be filled with fluid and deck rotated down before cutter can be hooked-up to a tractor.**

#### Fill Hydraulic Reservoir With Fluid

1. If fork lift is still under the cutter after unloading and parking the cutter, turn off ignition switch and remove switch key before dismounting unit to fill hydraulic reservoir.

**NOTE:** The hydraulic reservoir can be filled without the use of the fork lift if the Ditch Bank Cutter has been properly parked for storage after unloading.

**IMPORTANT:** Any high quality mineral based hydraulic fluid such as Mobilfluid 424 with a viscosity rating of 10W-30 is acceptable. For alternate fluids, search on the web for "Mobilfluid 424" or go to [www.mobil.com](http://www.mobil.com).

2. Remove fill cap (#15) and add 35 gallons of Mobilfluid 424 to the hydraulic reservoir. Use care to ensure that dust or other foreign particles do not contaminate the fluid.

#### Check Hose Loops

**Refer to Figure 1-2 on page 16:**

**IMPORTANT:** Hoses (#14) should loop up as shown and tilt slightly to the back to keep hoses from falling forward into the tractor tires. They also should be zipped tied together in three locations as shown.

1. Check hoses (#14) to make sure they loop up as shown and tilt back at the top.
2. If needed, loosen hoses at bulk head (#11) and tilt top of hose loops (#14) slightly back. Hold loops in this position and re-tighten hoses at the bulk head.
3. If additional movement is needed, loosen hose clamp (#8) and tilt hose loops slightly back. Hold loops in this position and re-tighten hose clamp bolt.
4. Check hose loops to make sure they are tied together with zip ties (#17) in the three locations shown. If not, add zip ties to the hoses as shown.

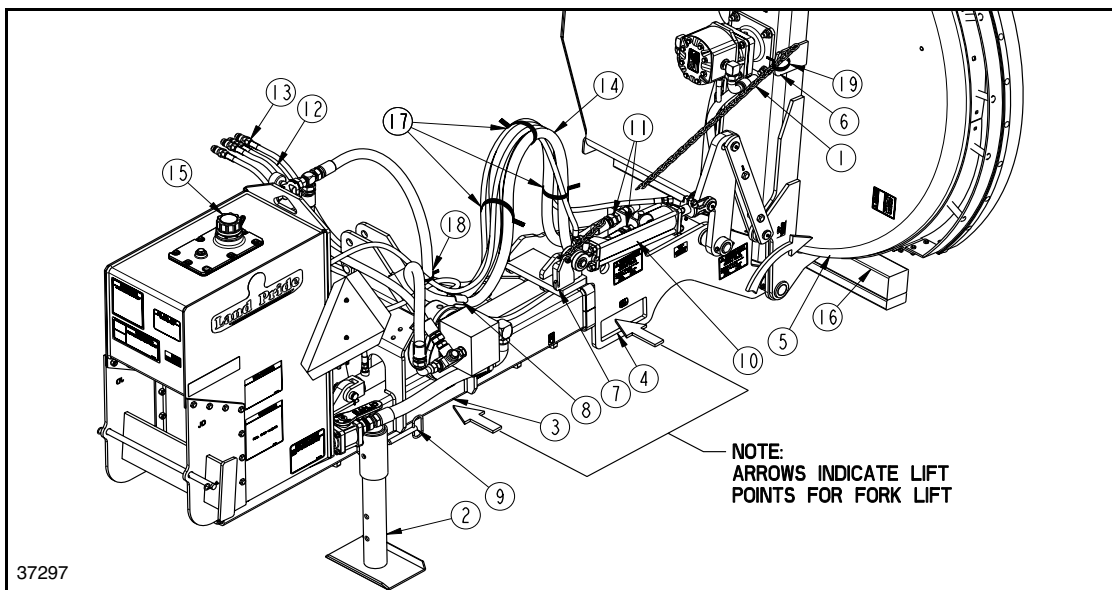

Preparation for Tractor Hook-up

Figure 1-2

### Rotate Deck Down

Refer to Figure 1-2:

#### DANGER

To avoid serious injury or death:

A pinching and/or crushing hazard exist while operating extension arm cylinder and/or deck pivot cylinder that can result in serious bodily injury or death. Do not operating these cylinders while someone is near the cutter.

1. Hydraulic reservoir should be filled with fluid, if not, fill reservoir with fluid. Refer to “**Fill Hydraulic Reservoir With Fluid**” on page 15.
2. If fork lift has been removed, reinsert right fork through slot (#4) in extension arm and left fork under mainframe (#3) as illustrated with arrows.
3. With the fork lift, raise Ditch Bank Cutter up approximately 12" above ground, set park brake, turn off engine, and remove switch key before dismounting fork lift.
4. Unbolt angle brackets securing support block (#16) to deck skid. Discard support block with angle brackets.
5. Remove detent pin (#9) and lower parking stand (#2) to the top hole in the stand. Replace detent pin (#9).
6. Back tractor to the cutter 3-point hitch. **Do not hook tractor to 3-point hitch at this time.**
7. Place transmission in park or set park brake, turn engine off, and remove switch key.
8. Hoses (#12 & #13) are connected to deck tilt cylinder (#10). Attach hydraulic hoses (#12 & #13) to a duplex outlet. It is best if connected to the 2nd control lever away from the operator. This control lever must be capable of being placed in float detent

position when gauge wheel is included and center detent when gauge wheel is not included.

9. Cut and remove zip tie (#19).
10. Return to the tractor seat, start tractor, and fully retract deck pivot cylinder (#10).
11. Shut tractor off and remove switch key before dismounting tractor.

#### DANGER

To avoid serious injury or death:

Make sure no one is standing in the deck fall area while unhooking the transport safety chain and lowering the deck. The deck could suddenly fall causing server injury or death.

**NOTE:** If transport safety chain (#1) is too tight to unhook, use a strap to pull on the deck until chain has enough slack to remove from deck hook (#6).

12. Unhook transport safety chain (#1) from deck hook (#6).
13. Store transport chain (#1) in storage hook (#7) by hooking the chain 15" from its free end. The chain should hang from the hook in 3 segments that are approximately equal in length.
14. Return to the tractor and operate tractor hydraulic control lever to lower the deck slowly until deck top is horizontal. Return control lever to center detent.
15. If running, shut tractor engine off and remove switch key before dismounting tractor.
16. Restart fork lift and lower cutter mainframe until cutter is resting on parking stand (#2) and deck (#5).
17. Slowly back fork lift away from cutter until forks are removed from the cutter. Park fork lift.





This page left blank intentionally.

## Section 1: Assembly & Set-up

### Tractor Hook-up

Refer to Figure 1-3:

#### WARNING

To avoid serious injury or death:

Lightweight tractors with rear attached implements may need weights added to the front to maintain steering control. Consult your tractor Operator's Manual to determine proper weight requirements and maximum weight limitations.

**IMPORTANT:** Hydraulic fluid must be added to the cutter hydraulic reservoir and shut-off valve turned fully open before operating the pump. Otherwise, the hydraulic pump will be damaged.

**IMPORTANT:** A quick hitch may be used, but is not recommended because it moves the implement back about 5" and impedes operator visibility.

**NOTE:** Driveline installation instructions will follow after hooking-up cutter to tractor as the distance between tractor power take-off shaft and speed increaser input shaft can vary from tractor to tractor.

### Prepare Cutter for Hook-up

1. Cutter should be on a flat, level, hard surface with extension arm cylinder (#9) retracted and deck tilt cylinder (#8) extended until deck is horizontal.
2. Make certain lower 3-point arms are stabilized to prevent excessive side-to-side movement.

### 3-Point Hook-up to Cat. II Standard Hitch

Refer to Figure 1-3:

1. Slowly back tractor up to cutter while using 3-point hydraulic controls to lower and position lift arm hitch holes between cutter clevis plates and in-line with clevis plate hitch pin holes.

2. Place tractor gear selector in park or set park brake, shut engine off, and remove ignition key.

**NOTE:** Refer to Figure 1-5 on page 19: Hitch spacer (#3) is not used with Cat. II 3-point standard hitch hook-up.

3. Attach Cat. II lower 3-point arms to lower clevises on the cutter with hitch pins (#2), flanged bushing (#1), and linchpins (#4).
4. Adjust length of top center link to align center link hitch hole with center hitch pin hole on the cutter.
5. Attach top center link to cutter using **customer supplied clevis pin (#6) and pin keeper (#7)**.
6. Connect hoses (#10 & #11) attached to extension arm cylinder (#9) to a single duplex outlet on the tractor. This is best if connected to the control lever closest to the operator.
7. If not already done, connect hoses (#12 & #13) to the 2nd control lever away from the operator. Hoses (#12 & #13) are attached to deck pivot cylinder (#8). This control lever must be capable of being placed in float detent position when gauge wheel is included.
8. Return to the tractor and slowly raise tractor 3-point hitch about 1 to 2 inches. Shut tractor engine off and remove switch key.
9. **Refer to Figure 1-2 on page 16:** Remove detent pin (#9) and raise parking stand (#2) to the bottom hole in stand. Replace detent pin (#9).
10. Slowly operate tractor's lower 3-point arms up and down to check clearance between cutter and tractor. Move or remove tractor drawbar if it interferes.
11. Adjust center top-link to level cutter frame from front to rear.
12. Adjust tractor's lower 3-point arms to level cutter frame from left to right.

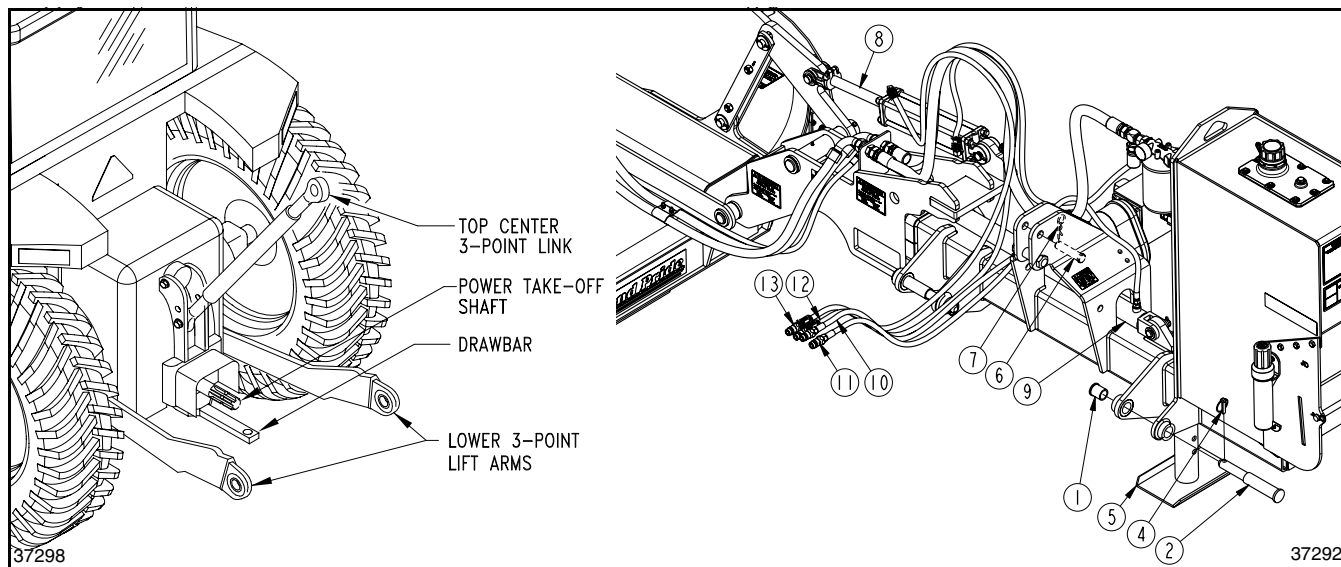

**Cat. II 3-Point Standard Hitch Hook-up**  
**Figure 1-3**

Section 1: Assembly & Set-up

13. Final deck leveling adjustments will be made later.
14. Push forward on control lever closest to the operator. Extension arm cylinder (#9) should extend the deck out. Pull back on control lever to retract extension arm.
  - a. If cylinder operates opposite direction desired, switch hoses at the duplex outlet for that cylinder.
  - b. Purge cylinder of air if it operates spongy or jerky. See **"Purge Hydraulic Cylinders"** on page 23.
15. Push forward on the second control lever. Deck pivot cylinder (#8) should extend, rotating deck down. Pull back on control lever and deck should rotate up.
  - a. If deck pivot cylinder operates opposite direction desired, switch hoses at the duplex outlet.
  - b. Purge cylinder of air if it operates spongy or jerky. See **"Purge Hydraulic Cylinders"** on page 23.
16. Driveline hook-up and speed increaser hook-up will be completed later.

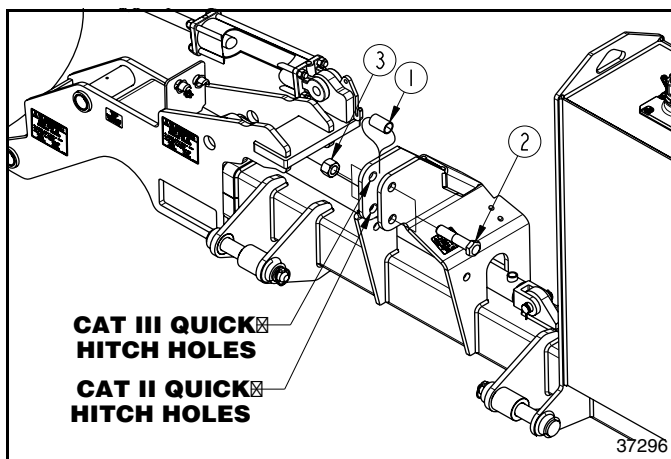

Upper Center Bushing Placement for Quick Hitches  
Figure 1-4

### Upper Center Bushing Placement

Refer to Figure 1-4:

The upper center bushing (#1) is located in the bottom hitch holes for Cat. II quick hitch and top hitch holes for Cat. III quick hitch. Bushing (#1) is not used with Cat. II standard hitch, but can be stored in the bottom hitch holes.

1. Attach bushing (#1) to bottom Cat. II quick hitch holes or top Cat. III quick hitch holes with 1"-8 x 4 1/2" GR5 bolt (#2) and nylock nut (#3).
2. Tighten nylock nut (#3) to the correct torque.

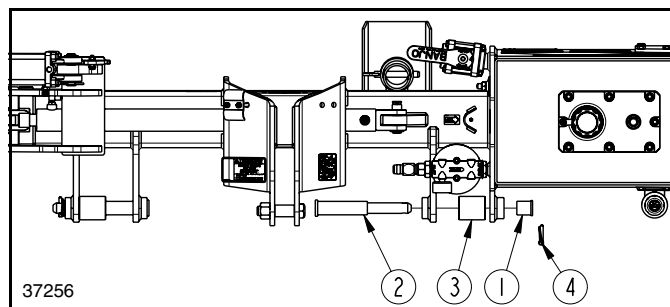

Lower Hitch Pin Set-up for Cat. II Quick Hitch  
Figure 1-5

### Lower Hitch Pin Set-up For Cat. II Quick Hitch

Refer to Figure 1-5:

1. Insert flange bushing (#1) through outside clevis plate as shown.
2. Insert hitch pin (#2) through inside clevis plate, hitch spacer (#3), and flange bushing (#1) in outside clevis plate.
3. Secure hitch pin (#2) with linchpin (#4).
4. Repeat steps 1 to 3 for the other hitch pin.
5. Refer to the Operator's Manual for quick hitch hook-up instructions and steps 6 to 16 starting on page 18 for hose hook-up and preliminary operational instructions.

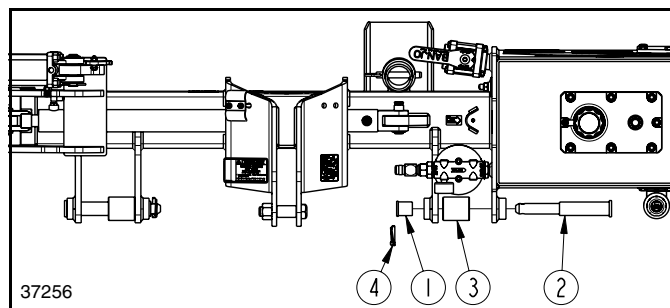

Lower Hitch Pin Set-up for Cat. III Quick Hitch  
Figure 1-6

### Lower Hitch Pin Set-up For Cat. III Quick Hitch

Refer to Figure 1-6:

1. Insert flange bushing (#1) through inside clevis plate as shown.
2. Insert hitch pin (#2) through outside clevis plate, hitch spacer (#3), and flange bushing (#1) in inside clevis plate.
3. Secure hitch pin with linchpin (#4).
4. Repeat steps 1 to 3 for the other hitch pin.
5. Refer to the Operator's Manual for quick hitch hook-up instructions and steps 6 to 16 starting on page 18 for hose hook-up and preliminary operational instructions.

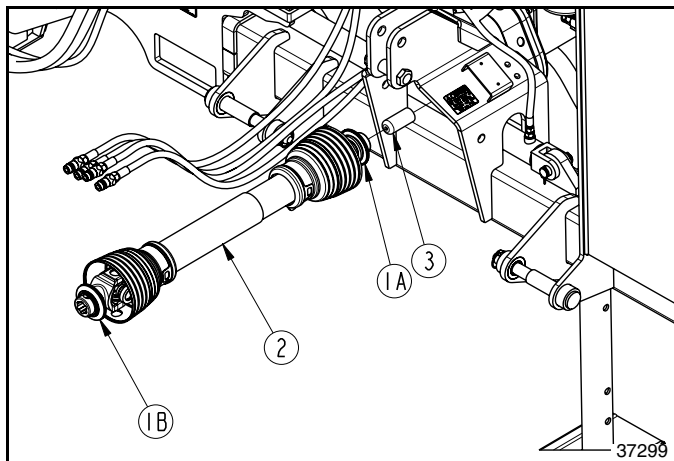

**Driveline Installation & Hook-up**  
Figure 1-7

### Driveline Installation (Optional)

Refer to Figure 1-7:

**IMPORTANT:** The driveline must be lubricated before putting it into service. Refer to “**Lubrication Points**” on page 44.

1. Remove shaft protector (#3) from speed increaser shaft and discard.
2. Pull back on inner yoke locking collar (#1A) and slide inner yoke of driveline (#2) over implement input shaft.
3. Release locking collar (#1A) and continue to push inner yoke onto input shaft until locking collar snaps in place.

### Driveline Hook-up (Optional)

#### DANGER

To avoid serious injury or death:

- Tractor power take-off shaft shield, driveline shields, and gearbox shaft shields must be installed and in good working condition to avoid driveline entanglement and projectiles flying off of the driveline.
- Do not engage power take-off while hooking-up or unhooking the driveline, or while someone is standing near the driveline. A person’s body and/or clothing can become entangled in the driveline.
- Do not use a power take-off adapter. The adapter will increase strain on the tractor’s power take-off shaft causing possible damage to shaft and driveline. It will also defeat the purpose of the tractor’s power take-off shield.
- Make certain driveline yokes are securely fastened at each end. A loose yoke can work free allowing the driveline to rotate uncontrollably causing implement damage and bodily injury or death to anyone nearby.

#### WARNING

To avoid serious injury or death:

- Always follow “Tractor Shutdown Procedure” provided in this manual before dismounting the tractor.
- Check driveline when lowering implement to make sure it does not interfere with the tractor drawbar at maximum depth. If needed, shut tractor off and move or remove drawbar to prevent driveline damage.

#### CAUTION

To avoid minor or moderate injury:

Some tractors are equipped with two power take-off speeds. Be certain your tractor’s power take-off is set at the implement’s rated power take-off speed or equipment breakage may result. DB Series are rated for 540 rpm and DBM Series are rated for 1000 rpm.

**IMPORTANT:** An additional driveline may be required if implement is attached to more than one tractor or if a Quick Hitch is used.

**IMPORTANT:** Check driveline minimum collapsible length before completing “**Driveline Hook-up**”. Structural damage to the tractor and implement can occur if this check is not made. Refer to “**Check Driveline Collapsible Length**” on page 21.

**IMPORTANT:** Do not engage tractor power take-off until driveline is fully connected and hydraulic fluid has been added to the cutter reservoir.

Refer to Figure 1-7:

1. If driveline collapsible length has not been checked, go to “**Check Driveline Collapsible Length**” on page 21. Otherwise, continue with step 2 below.
2. Park tractor and implement on a level surface.
3. Shut tractor down before dismounting. Refer to “**Tractor Shut Down Procedure**” on page 35.
4. If tractor drawbar interferes with driveline during hook-up, disconnect driveline and move drawbar forward, to the side, or remove.
5. Collapse driveline (#2) by pushing tractor end of driveline against the implement’s input shaft.
6. Pull back on driveline pull collar (#1B) and push yoke onto the tractor power take-off shaft. Release pull collar and continue to push driveline yoke forward until pull collar pops out and locks in place.
7. Pull on driveline yokes at the tractor and implement to make sure they are secured to the tractor power take-off shaft and implement input shaft.
8. Continue with “**Check Driveline Interference**” on page 22.

Section 1: Assembly & Set-up

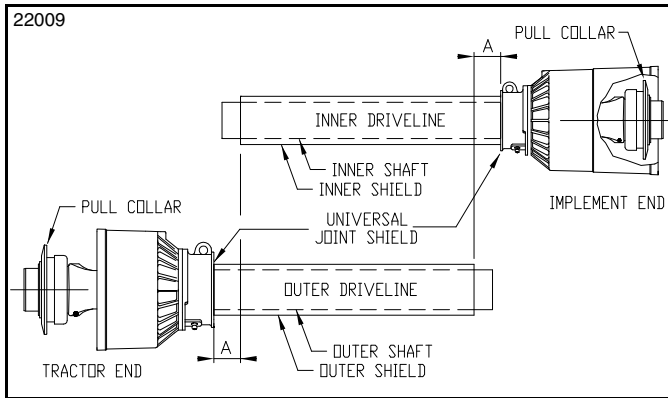

Driveline Shortening  
Figure 1-8

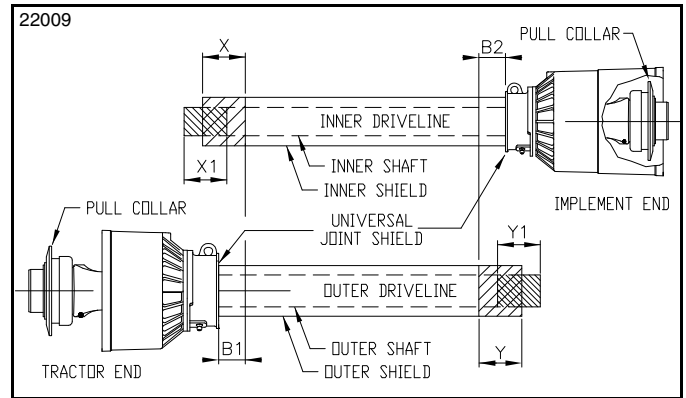

Driveline Shortening  
Figure 1-9

Check Driveline Collapsible Length

Refer to Figure 1-8:

**IMPORTANT:** A driveline that is too long can bottom out causing structural damage to the tractor and implement. Always check driveline minimum length during initial setup, when connecting to a different tractor, and when alternating between using a quick hitch and a standard 3-point hitch. More than one driveline may be required to fit all applications.

**IMPORTANT:** The power take-off shaft and gearbox input shaft must be aligned and level with each other when checking driveline minimum length. A driveline that is too long can damage tractor and implement.

1. With driveline attached only to the implement, remove outer driveline (tractor end) from inner driveline to separate the two profiles.
2. Park tractor and implement on a level surface.
3. Raise implement until implement input shaft is level with tractor power take-off shaft. Securely block implement at this height to keep unit from lowering.
4. Shut tractor down without removing support blocks. See **“Tractor Shut Down Procedure”** on page 35.
5. Attach outer driveline to the tractor’s power take-off shaft. Refer to steps 5-6 under **“Driveline Hook-up (Optional)”** on page 20.
6. Hold inner and outer drivelines parallel to each other. If dimension “A” is greater than or equal to 1”, then skip to **“Check Driveline Maximum Length”** on page 22. Otherwise continue with step 7.

Refer to Figure 1-9:

7. If dimension “A” was less than 1”, shorten driveline as follows:
  - a. Measure 1” (“B1” dimension) back from outer driveline shield and make a mark at this location on the inner driveline shield.
  - b. Measure 1” (“B2” dimension) back from the inner driveline shield and make a mark at this location on the outer driveline shield.
8. Remove outer driveline from the tractor power take-off shaft and inner driveline from the implement’s input shaft.
9. Cut off non-yoke end of inner driveline as follows:
  - a. Measure from end of inner shield to scribed mark (“X” dimension) and record.
  - b. Cut off inner shield at the mark. Cut same amount off the inner shaft (“X1” dimension).
10. Cut off non-yoke end of outer driveline as follows:
  - a. Measure from end of outer shield to scribed mark (“Y” dimension) and record.
  - b. Cut off outer shield at the mark. Cut same amount off the outer shaft (“Y1” dimension).
11. Remove all burrs and cuttings.
12. Continue with **“Check Driveline Maximum Length”** on page 22.



## Section 1: Assembly & Set-up

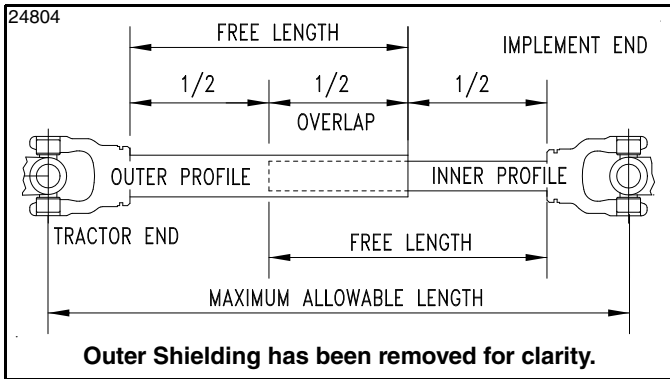

**Driveline Maximum Extended Length**  
Figure 1-10

### Check Driveline Maximum Length

**Refer to Figure 1-10:**

The driveline maximum allowable length must, when fully extended, have a minimum overlap of profile tubes by not less than 1/2 the free length with both inner and outer profile tubes being of equal length.

1. Apply multi-purpose grease to the inside of the outer shaft and reassemble the driveline.
2. Assemble the two driveline profiles together with just 1/2 overlapping of the profile tubes as shown. Once assembled, measure and record maximum allowable length here. \_\_\_\_\_
3. Reattach driveline to tractor power take-off shaft and gearbox shaft. Refer to “**Driveline Installation (Optional)**” on page 20 and “**Driveline Hook-up (Optional)**” on page 20.
4. Continue with “**Check Driveline Interference**” below.

### Check Driveline Interference

**Refer to Figure 1-11:**

#### **WARNING**

*To avoid serious injury or death:*

*A rotating driveline must not exceed an angle of 25 degrees up or down, and never engage a driveline while at an angle exceeding 25 degrees up or down. The driveline can break and send projectiles.*

1. Start tractor and raise implement slightly off the support blocks used to “**Check Driveline Collapsible Length**”. Drive forward until the implement is clear of the support blocks.

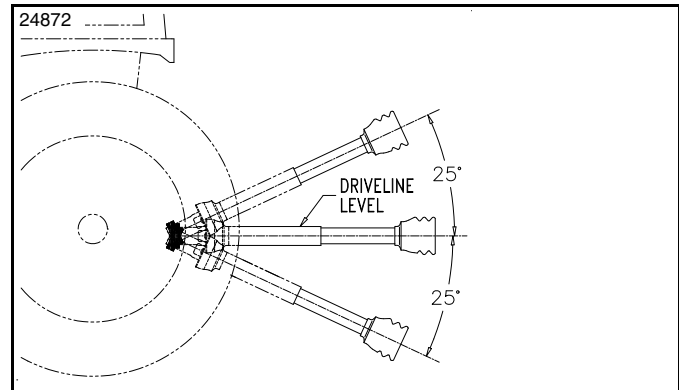

**Maximum Driveline Movement During Operation**  
Figure 1-11

2. Slowly and carefully lower and raise the implement to ensure drawbar, tires, and other equipment on the tractor do not contact the implement's frame. If there is an interference:
  - a. Back implement over the support blocks and lower it onto the blocks.
  - b. Shut tractor down before dismounting. Refer to “**Tractor Shut Down Procedure**” on page 35
  - c. Move or remove drawbar if it interferes with the implement and make any other necessary corrections.
  - d. Repeat steps 1-2 to verify the implement does not interfere with the tractor.
3. Start tractor, raise implement fully up. Back implement over the support blocks. Do not lower implement onto the support blocks.
4. Without changing the 3-point lift height, shut tractor down using “**Tractor Shut Down Procedure**” on page 35.
5. Check to make sure driveline does not exceed any of the limits listed below:
  - Driveline does not exceed maximum length recorded in step 2 under “**Check Driveline Maximum Length**” on this page.
  - Driveline angle does not exceed 25° above horizontal.
6. If driveline exceeds maximum allowable length or 25 degrees up:
  - a. Adjust tractor 3-point lift limiter to the height that will keep the driveline within the recommended limits.
  - b. If 3-point left lever does not have a lift height limiter, make a mark with tape or other means to indicate maximum lift height.
7. Start tractor, raise implement slightly, and drive forward enough to clear support blocks.
8. Lower implement to ground and shut tractor down using “**Tractor Shut Down Procedure**” on page 35.

## Section 1: Assembly & Set-up

### Speed Increaser Hook-up (Optional)

Refer to Figure 1-12:

1. Pull back on locking collar (#6) and slide spline bore of speed increaser over tractor power take-off shaft.
2. Release locking collar (#6) and continue to push speed increaser onto the power take-off shaft until locking collar snaps in place.
3. Push/pull on speed increaser/pump to be sure it is securely fastened to the tractor power take-off shaft.
4. Keep speed increaser/pump mounting plate (#1) vertical. Wrap chain (#2) around a stable non-moving component such as the drawbar. **Do Not** attach chain to hydraulic lines or hoses.

**IMPORTANT:** The chain (#2) should be fastened vertically downward without slack and angled slightly forward of bolt (#4) (toward the tractor) to avoid putting an end thrust on the gearbox.

5. Hook S-hook (#3) in one of the chain links and crimp to keep chain from coming loose.
6. Check S-hook (#3), bolt (#4), and mounting bolts (#5) to make sure they are secured. Tighten any bolts or nuts that are loose.

### Purge Hydraulic Cylinders

Purge hydraulic cylinder of air if the cylinder is operating spongy or jerky.

1. Set tractor control lever for the cylinder in center detent position.
2. Cycle the hydraulic cylinder by extending and retracting the cylinder several times to purge air from the hydraulic system.
3. If cylinder continues to not operate properly, loosen elbow fitting at the rod end of the hydraulic cylinder.
4. Slowly retract and extend the hydraulic cylinder until all trapped air is purged from the fitting.
5. Tighten elbow fitting to the cylinder.
6. Loosen elbow fitting from the base end of the hydraulic cylinder.
7. Slowly retract and extend hydraulic cylinder until all trapped air is purged from the fitting.
8. Tighten elbow fitting to the cylinder.
9. Clean oil spills around the cylinder fittings and equipment.
10. Recheck tractor hydraulic oil level. If needed add oil to the tractor reservoir. Refer to your tractor Operator's Manual for detail instructions.

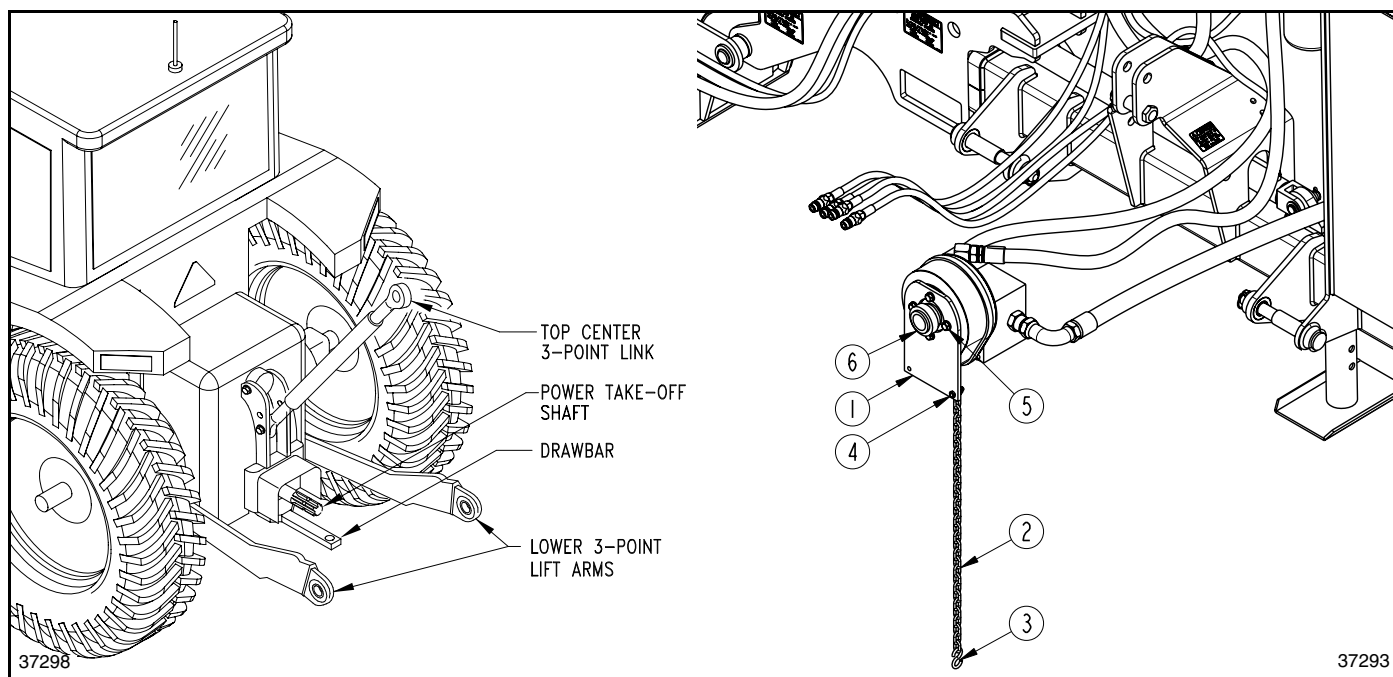

**Power Take-off Mounted Gearbox and Pump Hook-up**  
Figure 1-12

## Section 2: Options & Accessories Set-up

### Tailwheel (Optional)

**Tailwheel 60" Deck Boom Arm . . . . . 316-304A**

**Refer to Figure 2-1:**

If included, tailwheel pivot (#1) and adjustment bracket (#2) are shipped from the factory assembled to the deck.

1. Remove bolts (#4) and cut zip tie (not shown) securing tailwheel beam (#3) to pivot bracket (#1).
2. Center tailwheel beam (#3) between tailwheel adjustment bracket (#2) as shown and attach to tailwheel pivot bracket (#1) with 5/8"-11 x 3 1/2" GR5 bolt (#5) and hex top locknut (#7).
3. Draw hex top locknut (#7) up snug. Do not torque locknut tight.
4. Install one 1/2"-13 x 3 1/2" GR5 bolt (#4) below tailwheel beam (#3) and another above the beam.
5. Secure bolts (#4) with hex flange lock nuts (#6).
6. Insert two machine washers (#8) over end of yoke spindle (#10).
7. Insert yoke spindle (#10) into tailwheel beam (#3).
8. Insert one machine washer (#8) over end of yoke spindle (#10) and secure tailwheel assembly to tailwheel beam with roll pin (#9).

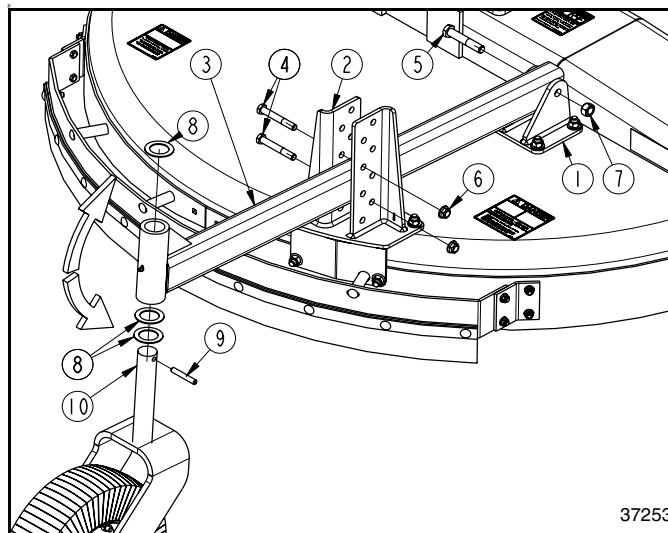

**Rear Gauge Wheel Installation  
Figure 2-1**

### Side Gauge Wheel (Optional)

**Refer to Figure 2-2:**

**Side Gauge Wheel . . . . . 316-314A**

If included, the side gauge wheel (#1) is shipped from the factory fully assembled to the deck.

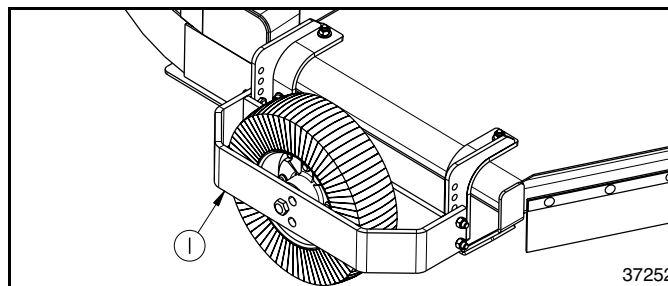

**Side Gauge Wheel Installation  
Figure 2-2**

### Weight Hanger Assembly (Optional)

**Refer to Figure 2-3:**

A right-hand overturning torque load is present on the tractor when extension arm is fully extended. Auxiliary weights can be added to the left rear tractor wheel to help offset this overturning load. In addition, 100 lbs suitcase type weights can be added to one of Land Pride's six optional weight hangers. Make sure your weights match the weight hanger. The weight hangers are identified by the company's initials cut into the side plates.

### CAUTION

*To avoid minor or moderate injury:*

*Although weights can be added to minimize risk of overturning tractor, the weights do not eliminate the risk. Caution should be used at all times.*

One of the six optional "**Bolt-on Weight Hangers**" must be installed for operation. See "**Bolt-on Weight Hangers**" on page 25 for detailed descriptions.

- Weight Hanger Assy, John Deere . . . . . 316-230A**
- Weight Hanger Assy, Case . . . . . 316-231A**
- Weight Hanger Assy, IH . . . . . 316-232A**
- Weight Hanger Assy, Case/IH . . . . . 316-233A**
- Weight Hanger Assy, New Holland . . . . . 316-234A**
- Weight Hanger Assy, Kubota . . . . . 316-276A**

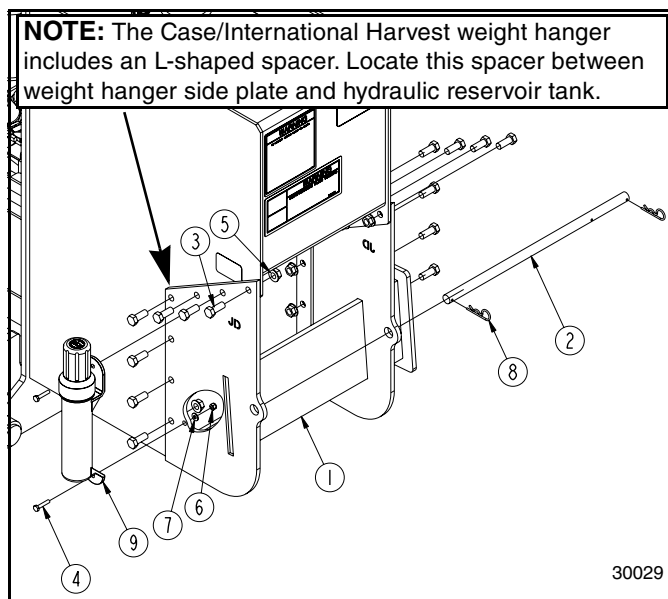

**Weight Hanger Installation  
Figure 2-3**

1. Attach weight hanger (#1) to reservoir with fourteen 1/2"-13 x 1 1/4" GR5 cap screws (#3) and hex flange lock nuts (#5). Tighten lock nuts to the correct torque.



## Section 2: Options & Accessories Set-up

2. Attach manual storage container (#9) to the front side of the reservoir with two 1/4"-20 x 1 1/4" GR5 cap screws (#4), flat washers (#7), and hex nylock nuts (#6). Tighten nylock nuts to the correct torque.
3. Insert weight retainer pin (#2) through holes in weight hanger and secure with hairpin cotter (#8).

### Bolt-on Weight Hangers

Refer to Figure 2-4:

The weight hanger is attached to the left side of the hydraulic reservoir. See “**Weight Hanger Assembly (Optional)**” on page 24 for attachment instructions.

**IMPORTANT:** Adding weights to the reservoir can lighten the tractor’s front end. Front tractor weights and/or ballast to tires may be required to offset cutter and auxiliary weights. Consult your tractor’s manual to determine if additional ballast is needed.

**IMPORTANT:** Suitcase type weights illustrated with weight hangers are provided by the customer. Make sure the suitcase weights are the same brand name and match the weight hanger. **Not all suitcase weights of the same brand name match Land Pride weight hangers designed for that brand.**

30027

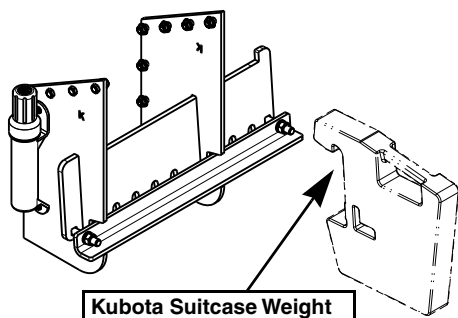

**Bolt-on Weight Hanger Part No. 316-276A**  
Use Only with illustrated Kubota suitcase weights

Use only with illustrated IH suitcase weights

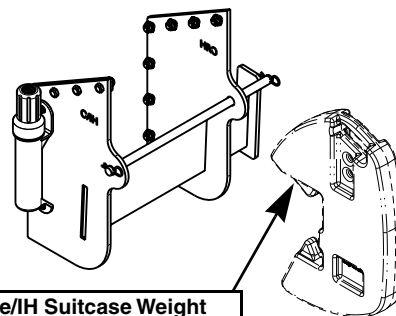

**Bolt-on Weight Hanger Part No. 316-233A**  
Use only with illustrated Case/IH suitcase weights

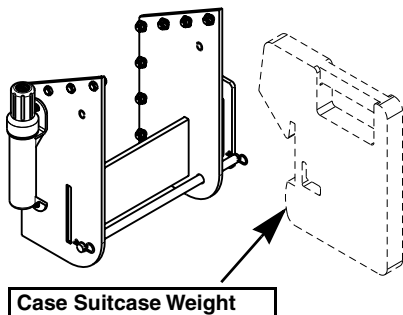

**Bolt-on Weight Hanger Part No. 316-231A**  
Use only with illustrated Case suitcase weights

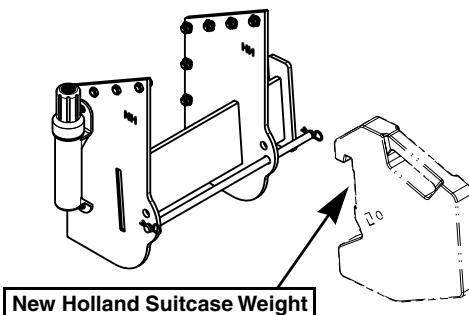

**Bolt-on Weight Hanger Part No. 316-234A**  
Use Only with illustrated New Holland suitcase weights

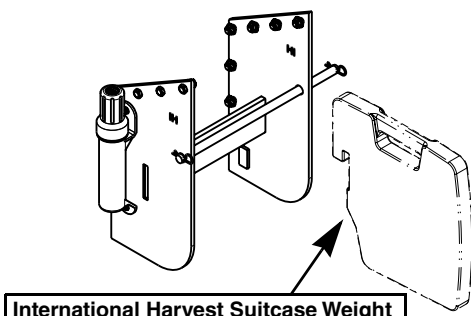

**Bolt-on Weight Hanger Part No. 316-232A**

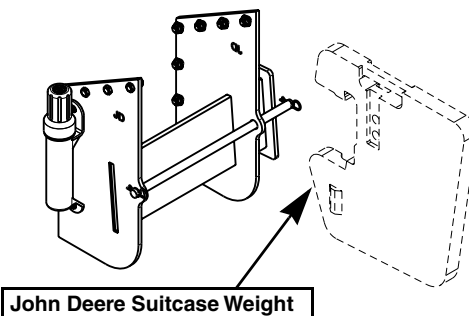

**Bolt-on Weight Hanger Part No. 316-230A**  
Use only with illustrated John Deere suitcase weights

**Bolt-on Weight Hangers**  
Figure 2-4

## Optional Front Guard Assemblies

### DANGER

To avoid serious injury or death:

Rotary cutters have the ability to discharge objects at high speeds; therefore, the use of front and rear safety guards is required at all times when operating the Ditch Bank Cutter.

### Front Rubber Guard

Refer to Figure 2-5:

#### Front Rubber Guard Complete 312-844A

1. Install Front Rubber Guards (#5 & #6) as shown with 3/8"-16 x 1" GR5 carriage bolts (#3), front deflector straps (#1 & #2), and hex whiz nuts (#4).
2. Tighten all nuts to the correct torque.

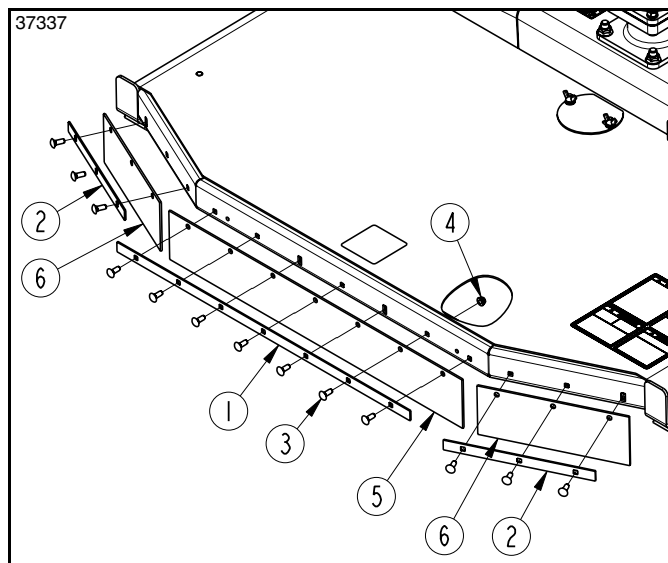

Front Rubber Guard Installation  
Figure 2-5

### Front Single or Double Chain Guard

Refer to Figure 2-6:

#### Front Chain Guard Complete 312-845A

#### Front Double Chain Guard 316-319A

1. Install front chain guards (#1 & #4) as shown with 3/8"-16 x 1" GR5 carriage bolts (#2), and hex whiz nuts (#3).
2. Tighten all nuts to the correct torque.

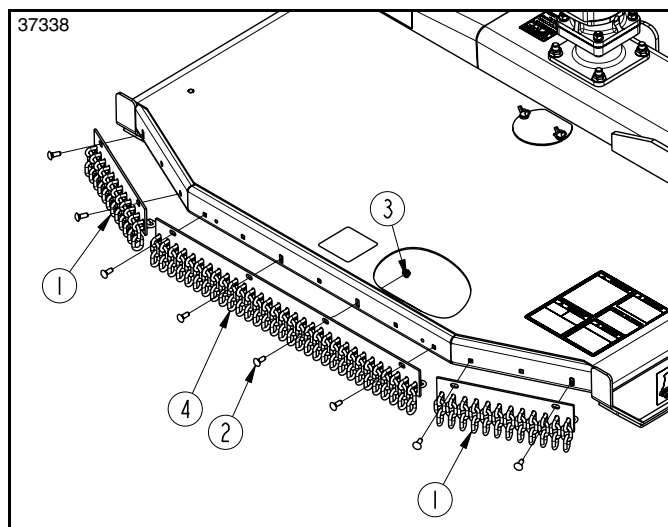

Front Chain Guard (Single or Double) Installation  
Figure 2-6

Section 2: Options & Accessories Set-up

Optional Rear Guard Assemblies

**⚠ DANGER**

To avoid serious injury or death:

Do not operator cutter without a rear guard. Do not remove rear guard unless it is replaced by an approved Land Pride guard. Serious body injury or loss of life can result without an attached rear guard.

**Rear Rubber Guard**

Refer to Figure 2-7:

**Rear Rubber Guard . . . . . 316-336A**

1. Install rear rubber guard (#5) with 3/8"-16 x 3 1/2" GR5 carriage bolts (#3), deflector spacer (#1), and 3/8" whiz nuts (#4). Draw nuts up snug, do not tighten at this time.
2. Attach both ends of rear rubber guard (#5) to the deck as shown with 3/8"-16 x 1" GR5 carriage bolts (#2), and hex whiz nuts (#4).
3. Tighten all hex whiz nuts (#4) to the correct torque.

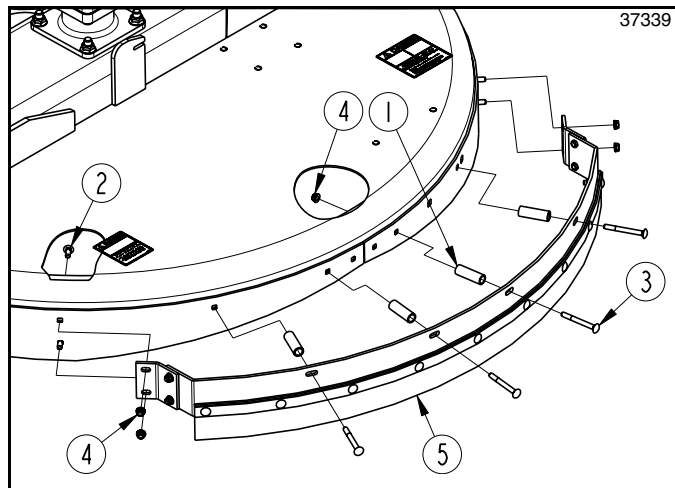

Rear Rubber Guard Installation  
Figure 2-7

**Rear Single or Double Chain Guard**

Refer to Figure 2-8:

**Rear Chain Guard . . . . . 316-335A**

**Rear Double Chain Guard . . . . . 316-318A**

1. Install rear chain guard (#5) with 3/8"-16 x 3 1/2" GR5 carriage bolts (#3), deflector spacers (#1), and 3/8" whiz nuts (#4). Draw nuts up snug, do not tighten at this time.
2. Attach both ends of rear chain guard (#5) to the deck as shown with 3/8"-16 x 1" GR5 carriage bolts (#2), and hex whiz nuts (#4).
3. Tighten all hex whiz nuts (#4) to the correct torque.

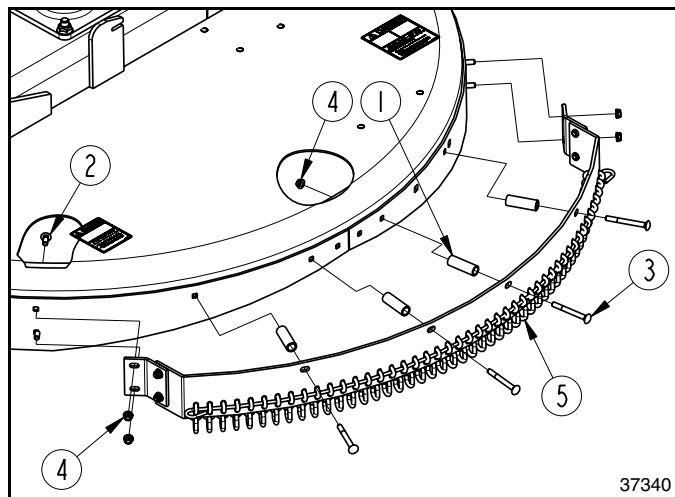

Rear Chain Guard (Single or Double) Installation  
Figure 2-8

**Slow Moving Vehicle Sign (Accessory)**

Refer to Figure 2-9:

Land Pride offers as an accessory the SMV sign with attached mounting blade (#1) should your tractor not be equipped with a removable SMV sign or should your SMV sign not fit Land Pride's SMV mounting socket (#4). Also, mounting components (#2, #3, & #4) can be purchased from your nearest Land Pride dealer should you want to mount this SMV sign on another piece of equipment.

Item	Part No.	Description
1	316-362S	SMV Sign
2	802-092C	RHSNB 5/16-18X3/4 GR5
3	803-177C	NUT HEX FLG TP LK 5/16-18ZNYCR
4	890-401C	SMV MOUNTING SOCKET

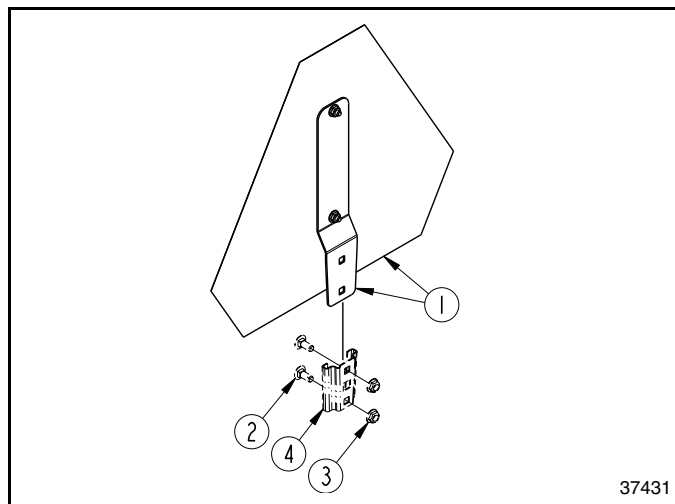

Slow Moving Vehicle Sign  
Figure 2-9

Section 2: Options & Accessories Set-up

**Protective Shield (Accessory)**

An optional operator protective shield is available for use on tractors not equipped with cabs or other protective shielding. This shield is a “universal” type and is suitable for attachment to a conventional Roll Over Protective Structure (ROPS) that is already attached to the tractor. It is constructed of an extruded aluminum frame and glazed with 1/4" clear lexan polycarbonate.

Mounting hardware will permit attachment to ROPS having cross-section dimensions of 2" x 4", 2" x 5", and 2" x 6" or 2 1/2" x 4", 2 1/2" x 5", and 2 1/2" x 6". Other sizes may require longer mounting bolts and/or custom flatbars. Installation requires that 4 mounting holes be drilled in the frame of the shield. No modification is made to the ROPS.

**Operator Protective Shield . . . . . 316-063A**

**Protective Shield Installation**

*Refer to Figure 2-10:*

1. Measure width and thickness of the tractor ROPS bar to determine if the clamping hardware supplied will be adequate.
2. Compare parts list and quantities with parts received. Report any missing or damaged items to your dealer.

**NOTE:** To determine the best location for the protective shield, the cutter should be connected to the tractor, extension arm should be fully extended and the deck should be approximately level in cutting position.

3. Carefully remove the shield from the shipping carton and temporarily position it on the inside surface of the ROPS bar. Locate shield forward/back and up/down to provide the best overall coverage for the tractor operator. Use a spirit level to level the shield before marking. Mark frame location with a pencil on each side of the ROPS bar, and mark vertical ROPS location on the shield frame.
4. Position protective shield (#5) on a flat work surface. Locate one of the flatbars (#4) next to the pencil marks to determine which set of holes will clear the vertical marks for the ROPS location. Mark hole location and drill two 1/4" diameter holes through the shield frame. Similarly mark and drill two additional holes for the lower clamp location.
5. Attach shield to the inside surface of the ROPS bar with 1/4" x 4" cap screw (#6), 1/4" flat washers (#3), 1/4" lock washer (#2), and 1/4" nut (#1).

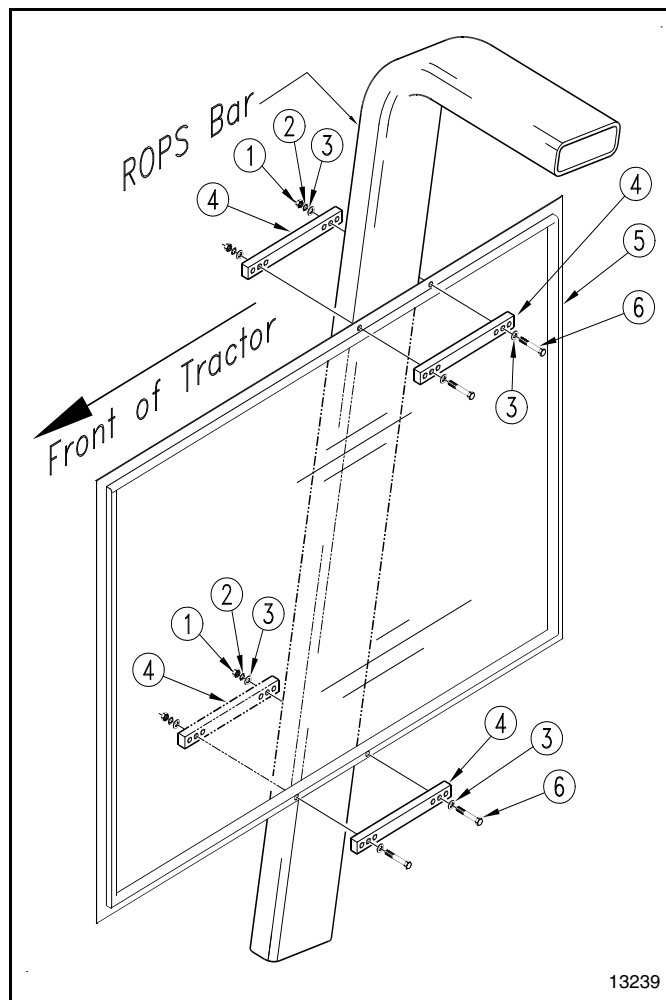

**Operator Protective Shield  
Figure 2-10**

Section 3: Hydraulic Plumbing

**Hydraulic Plumbing For Pump**

If speed increaser/pump is mounted on the cutter, Refer to Figure 3-1:

If speed increaser/pump is mounted to the tractor power take-off shaft, Refer to Figure 3-2:

**IMPORTANT:** Before engaging tractor power take-off, make sure reservoir is full of hydraulic oil, shut-off valve is fully open, and speed increaser/pump hydraulic plumbing is configured correctly.

The hydraulic motor on the deck is powered by a tractor driven power take-off speed increaser/pump receiving fluid from the 35 gallon reservoir.

If cutter blades stall, an overpressure relief valve opens to return oil to the reservoir. All returned oil is filtered of particulates before dumping into the reservoir. Case drain oil is not filtered.

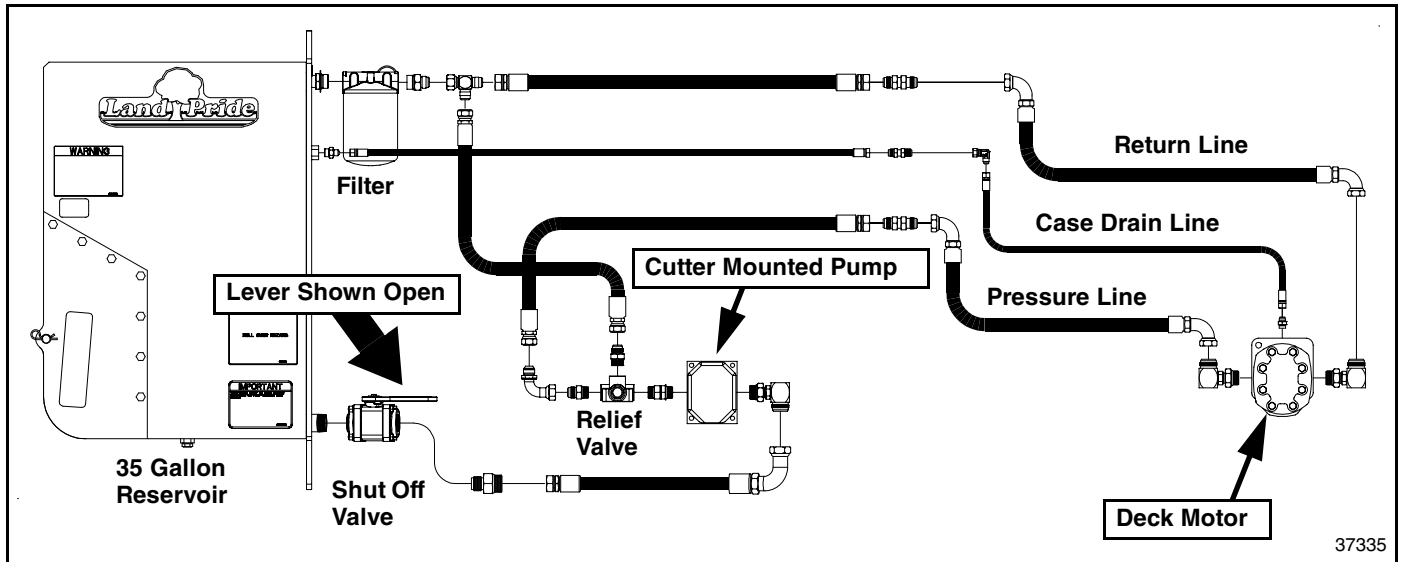

Hydraulic Hose Plumbing for Cutter Mounted Speed Increaser & Pump  
Figure 3-1

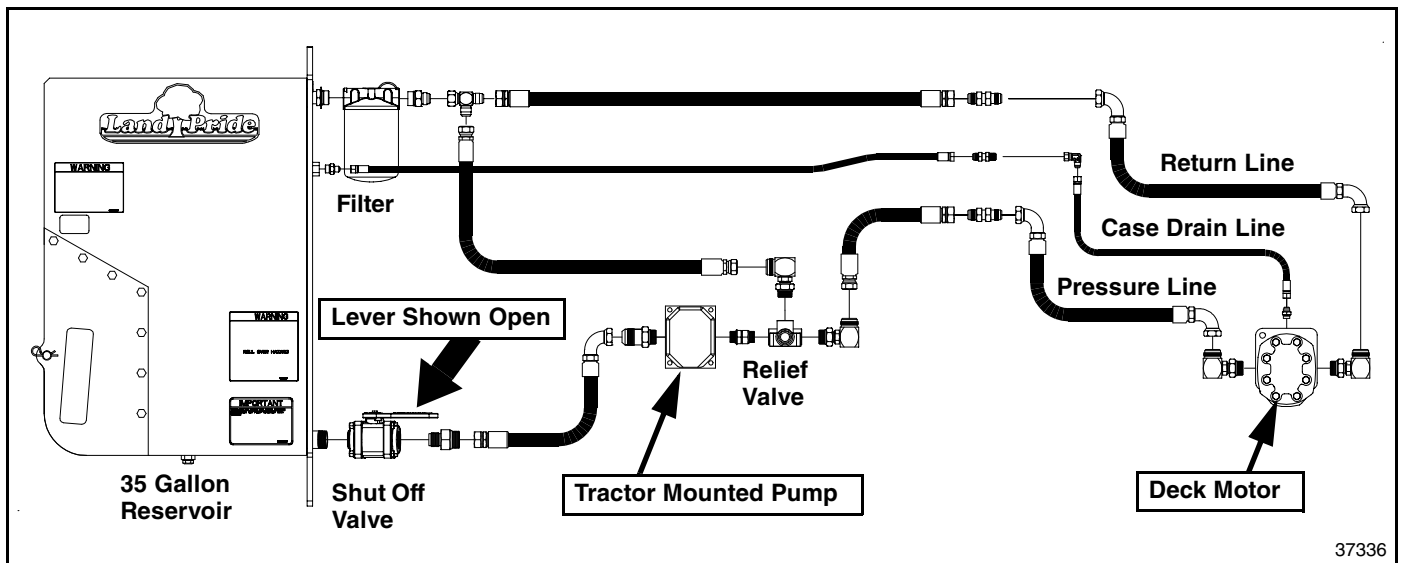

Hydraulic Hose Plumbing for Tractor Mounted Speed Increaser & Pump  
Figure 3-2

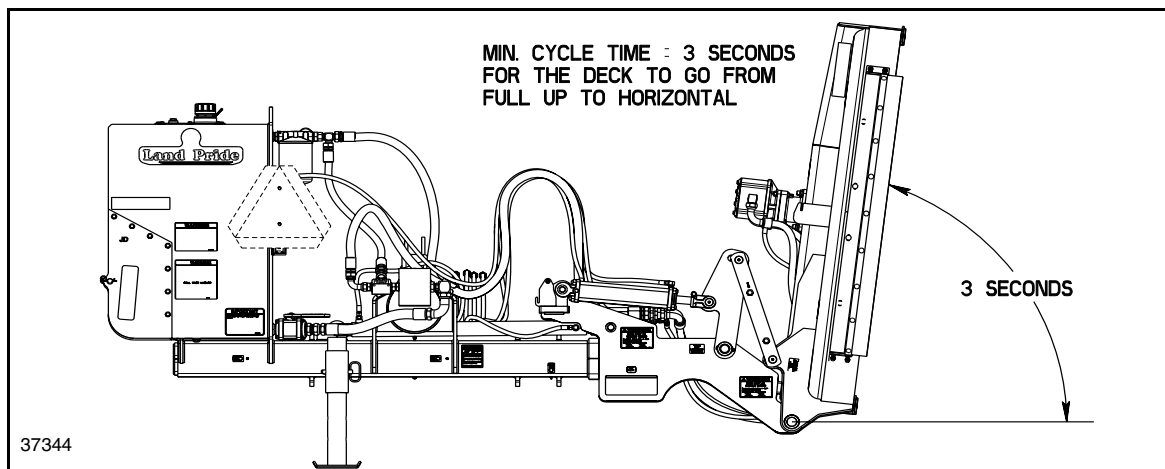

**Cycle Time (Fully Retracted to Horizontal)**  
Figure 4-1

### Turtle/Rabbit Flow Control

Refer to Figure 4-1:

**NOTE:** If your tractor does not have flow control (turtle/rabbit control) or if the tractor uses an open center hydraulic system, then Flow Control Valve Kit #316-068K must be purchased. Check your tractor Operator's Manual to determine your tractor's set-up.

1. Set cutter deck in transport position. Extension arm cylinder and deck pivot cylinder should be fully retracted.

### WARNING

To avoid serious injury or death:

Cycle time for the deck to rotate from fully up to parallel with the ground must not be less than 3 seconds. A cycle time less than 3 seconds can cause damage to the equipment and cause bodily injury or death to someone near the deck.

2. Operate control lever to extend deck pivot cylinder until deck is rotated down parallel with the ground. Time how long it takes to rotate the deck down.
3. Adjust turtle/rabbit control for the deck pivot cylinder until cycle time is 3 seconds or longer.

**NOTE:** If cutter is having hydraulic overheating problems and turtle/rabbit flow control valve has been set correctly, then check tractor Operator's Manual for power beyond hook-up.

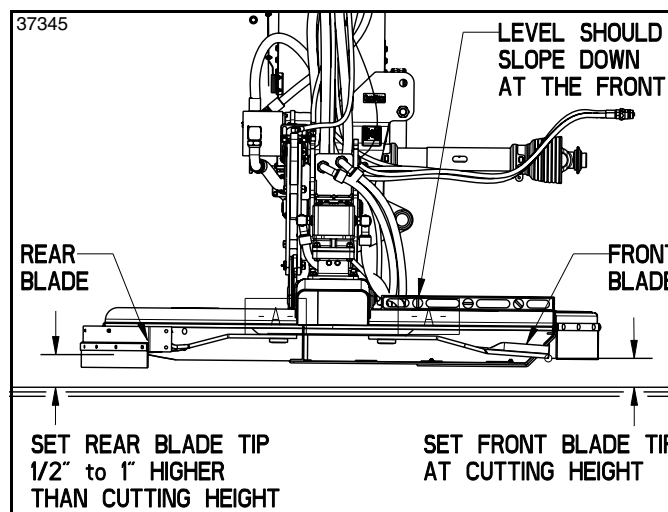

**Front to Back Deck Leveling**  
Figure 4-2

**IMPORTANT:** The front blade tip should be lower than rear blade tip by 1/2" to 1". The cutter is subject to continuous material flow under the deck if rear blade is at the same height or lower than the front blade. This will cause horsepower loss, grass clumps, blade wear, and frequent blade sharpening.

1. Place tractor control levers for extension arm cylinder and deck pivot cylinder in self-cancel detent position.
2. Fully retract extension arm cylinder.
3. Adjust deck pivot cylinder to rotate deck top down until it is parallel with the ground.
4. Lower 3-point arms until deck and/or optional gauge wheel are off the ground 2" to 3".
5. Place a level on the cutter deck as shown in illustration above.
6. Adjust center 3-point link until top of cutter deck is approximately 1/2" to 1" lower at the front than at the back. Level should slope down to the front.

### Deck Leveling Front to Back

Refer to Figure 4-2:

Deck level adjustments should be made on a level surface large enough to cover area under tractor and deck with extension arm fully retracted.



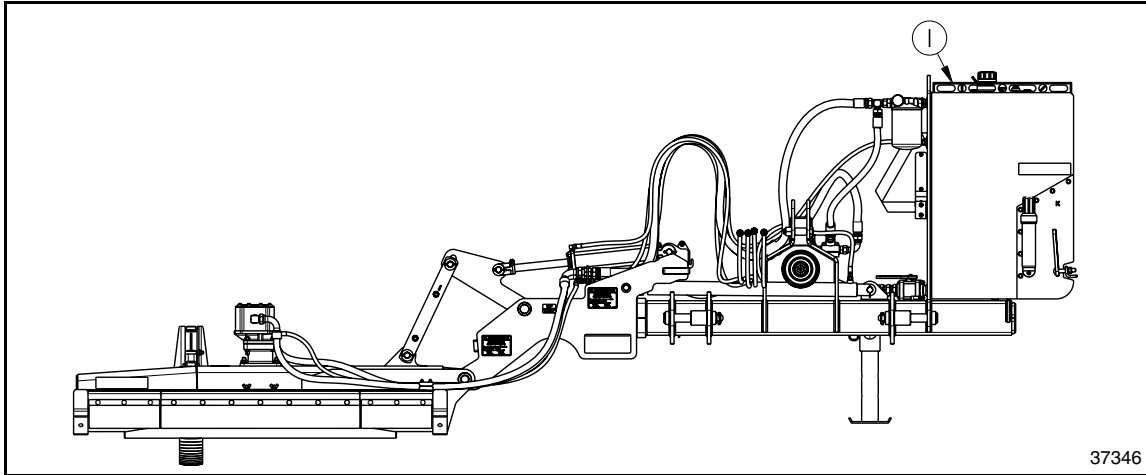

Frame Leveling Left to Right  
Figure 4-3

37346

### Frame Leveling Left to Right

Refer to Figure 4-3:

Usually the cutter frame is leveled left to right as follows:

1. Place a level (#1) across the top of the reservoir as shown to verify levelness.
2. Manually adjust one or both of the tractor's lower 3-point arms up or down until reservoir is level.

The right 3-point arm can be raised and left 3-point arm lowered to clear embankments that otherwise would cause driveline angle to exceed 25° to clear the embankment. Refer to “**Angle Problems With Driveline**” below.

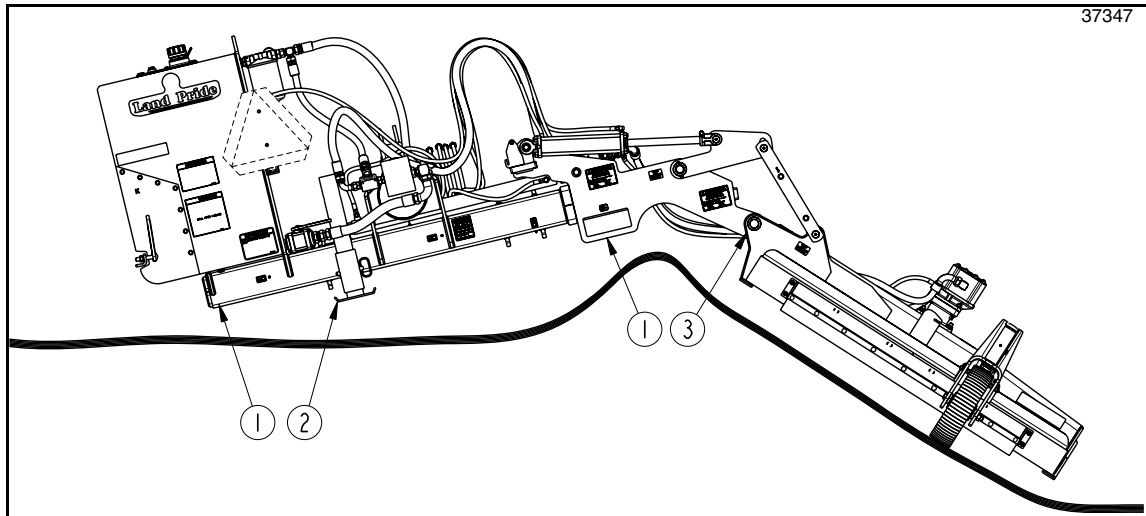

Frame Angling to Clear Embankment  
Figure 4-4

37347

### Angle Problems With Driveline

Refer to Figure 4-4:

The driveline angle can not exceed 25° when raising 3-point arms to clear embankments. Refer to “**Check Driveline Interference**” on page 22 for driveline interference instructions. When driveline angle exceeds 25°, manually adjust lower 3-point arms as follows:

1. Adjust right arm up and left arm down an equal number of turns to raise deck pivot point higher than the embankment.

**IMPORTANT:** Be careful to avoid hitting uneven ground and raised objects with cutter frame (#1), parking stand (#2), and deck pivot point (#3) when traveling with 3-point arms set at different vertical lengths.

## Section 4: Adjustments

### Cutting Height Adjustment

Depending on cutter set-up, there are three methods to adjust cutting height. Determine which cutter set-up you have and follow those instructions.

- Cutting Height Without Gauge Wheel
- Cutting Height With Side Gauge Wheel
- Cutting Height With Rear Gauge Wheel

#### DANGER

To avoid serious injury or death:

A pinching and/or crushing hazard exist while operating extension arm cylinder and/or deck pivot cylinder that can result in serious bodily injury or death. Do not operate these cylinders while someone is near the cutter.

**IMPORTANT:** Make all cutting height adjustments in the field using height of cut grass/material as a guide. Do not measure blade height above ground as the non-operating blade height will be different than the operating blade height.

### Cutting Height Without Gauge Wheel

1. Set 3-point control lever to self-cancel detent.
2. Use 3-point control lever to adjust cutter to the approximate desired cutting height.
3. With tractor engine at an idle, engage blades. See instructions for “**Blade Engagement & Disengagement**” on page 38.
4. Travel forward approximately 20 to 50 feet.
5. Stop tractor, disengage power take-off, place tractor gear selector in park or set park brake, shut off tractor, remove key, and wait for blades to come to a complete stop before dismounting tractor.
6. Measure height of cut grass/material. This distance is the cutting height. If this height is acceptable, set 3-point control lever to stop at this height.
7. If this height is unacceptable, repeat steps 1 to 6 until desired cutting height is achieved.

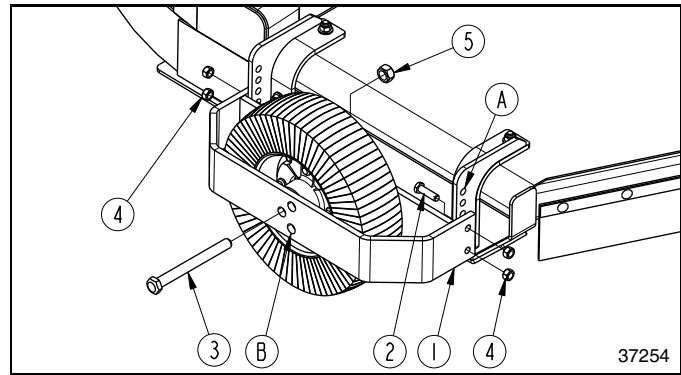

Side Gauge Wheel Adjustment  
Figure 4-5

### Cutting Height With Side Gauge Wheel

Refer to Figure 4-5:

1. Park cutter on a flat, level, hard surface with extension arm cylinder retracted.
2. Extend deck pivot cylinder until deck is horizontal.
3. Lower tractor 3-point arms until deck is several inches higher than desired cutting height.
4. Place tractor gear selector in park or set park brake, shut engine off, and remove ignition key.
5. Place support blocks or jack stands under the deck's skid shoes.
6. Without starting the tractor, lower 3-point arms until deck skid shoes are resting on the supports.
7. Remove bolts (#2) and adjust side gauge wheel frame (#1) up or down to one of the holes “A” that is closest to the desired cutting height.
8. Replace 1/2"-13 x 1 3/4" GR5 bolts (#2) and lock nuts (#4). Tighten lock nuts to the correct torque.
9. If additional adjustments are required, remove spindle bolt (#3) and adjust gauge wheel up or down to one of the other holes “B” that best meets desired cutting height.
10. Replace 3/4"-10 x 7 1/2" GR5 spindle bolt (#3) and secure with locknut (#5). Tighten locknut to the correct torque.
11. Return to the tractor, raise 3-point arms up, travel forward to clear support blocks.
12. At the worksite, lower cutter down to cutting height and engage blade. See instructions for “**Blade Engagement & Disengagement**” on page 38.
13. Travel forward cutting grass for 20 to 50 feet and stop.
14. Disengage power take-off, place tractor gear selector in park or set park brake, shut engine off, and remove ignition key. Wait for all components to stop before dismounting tractor.
15. Dismount tractor and check cutting height of grass.
16. If needed, repeat “**Cutting Height With Side Gauge Wheel**” above until cutter is set at the correct height.



## Section 4: Adjustments

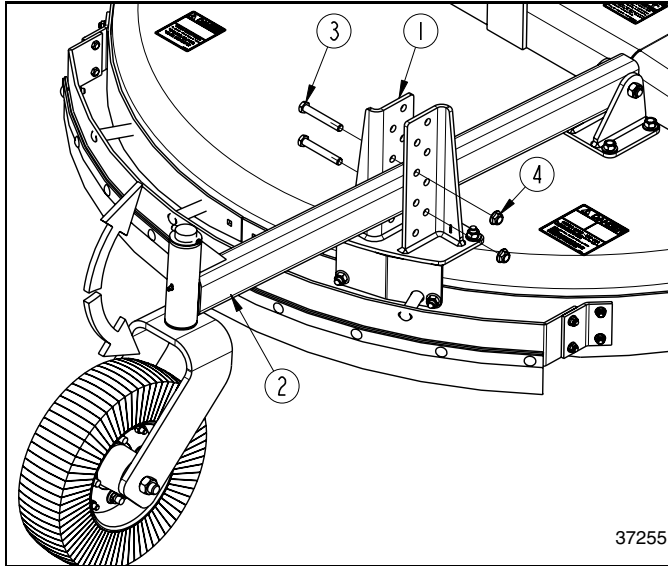

Rear Tailwheel Adjustment  
Figure 4-6

### Cutting Height With Rear Gauge Wheel

Refer to Figure 4-6:

1. Park cutter on a flat, level, hard surface with extension arm cylinder retracted.
2. Extend deck pivot cylinder until deck is horizontal.
3. Lower tractor 3-point arms until deck is several inches higher than desired cutting height.
4. Place tractor gear selector in park or set park brake, shut engine off, and remove ignition key.
5. Place support blocks or jack stands under the deck's skid shoes.
6. Without starting the tractor, lower the 3-point arms until deck skid shoes are resting on the supports.
7. Remove bolts (#3) and adjust tailwheel (#2) up or down as desired.
8. Reinstall 1/2"-13 x 3 1/2" GR5 bolts (#3) and secure with hex flange lock nuts (#4).
9. Tighten hex flange lock nuts (#4) to the correct torque.
10. Return to the tractor, raise 3-point arms up, travel forward to clear support blocks.
11. At the worksite, lower cutter down to cutting height and engage blade. See instructions for "**Blade Engagement & Disengagement**" on page 38.
12. Travel forward cutting grass for 20 to 50 feet and stop.
13. Disengage power take-off, place tractor gear selector in park or set park brake, shut engine off, and remove ignition key. Wait for all components to stop before dismounting tractor.
14. Dismount tractor and check cutting height of grass.
15. If needed, repeat "**Cutting Height With Rear Gauge Wheel**" above until cutter is set at the correct height.

## Section 5: Operating Procedures

### Startup Checklist

The DB2660 Ditch Bank Cutter is an uniquely versatile and powerfully productive cutting implement in the hands of a knowledgeable, skilled, and responsible operator. This cutter is frequently operated on inclines in populated and high traffic areas. Therefore, it is absolutely essential that no one operates this cutter unless they are age 16 or older and have read, fully understood, and are totally familiar with the Operator's Manual. Make sure the operator has paid particular attention to:

- **Important Safety Information**, page 1
- **Section 1: Assembly & Set-up**, page 14
- **Section 2: Options & Accessories Set-up**, page 24
- **Section 4: Adjustments**, page 30
- **Section 5: Operating Procedures**, page 34
- **Section 6: Maintenance & Lubrication**, page 41
- **Section 9: Troubleshooting**, page 53

### Safety Information

#### DANGER

To avoid serious injury or death:

- Cutter blades can be rotating with deck off the ground and at all kinds of angles to the ground. Keep all personnel away while cutter blades are rotating. Rotating cutter blades can cause serious injury or death.
- Do not engage power take-off while hooking-up or unhooking the driveline, or while someone is standing near the driveline. A person's body and/or clothing can become entangled in the driveline.
- Tractor power take-off shaft shield, driveline shields, and gearbox shaft shields must be installed and in good working condition to avoid driveline entanglement and projectiles flying off of the driveline.
- All guards and shields must be installed and in good working condition while operating the implement.
- Do not use cutter as a fan. Cutting blades are not properly designed or guarded for this use.
- A pinching and/or crushing hazard exist while operating extension arm cylinder and/or deck pivot cylinder that can result in serious bodily injury or death. Do not operating these cylinders while someone is near the cutter.
- Always disconnect driveline from the tractor and secure implement in the up position with solid, non-concrete supports before servicing the underside. A person can become entangled in the drivetrain if the tractor is started and power take-off is engaged or crushed by an unsupported implement.
- Never place hands or feet under the deck or attempt to make adjustments to the cutter with power take-off engaged. Cutter blades rotating at high speeds cannot be seen and are located close to the deck sides. Body extremities will be cut off instantly.

- Rotary Cutters have the ability to discharge objects at high speeds; therefore, the use of front and rear safety guards is mandatory with this cutter. Stop blade rotation if a bystander is in or around the area.
- Always use a tractor equipped with protective equipment designed to shield operator from thrown objects and protect operator from tractor rollover. Always fasten seat belt snugly and securely when operating the Ditch Bank Cutter. Operating the Ditch Bank Cutter without proper protective equipment can result in bodily injury or death.
- Do not use a power take-off adapter. The adapter will increase strain on the tractor's power take-off shaft causing possible damage to shaft and driveline. It will also defeat the purpose of the tractor's power take-off shield.
- Make certain driveline yokes are securely fastened at each end. A loose yoke can work free allowing the driveline to rotate uncontrollably causing implement damage and bodily injury or death to anyone nearby.

#### WARNING

To avoid serious injury or death:

- Do not operate and/or travel across inclines where tractor and/or implement can roll over. Consult your tractor's manual for acceptable inclines the tractor is capable of traveling across.
- Lightweight tractors with rear attached implements may need weights added to the front to maintain steering control. Consult your tractor Operator's Manual to determine proper weight requirements and maximum weight limitations.
- Allow only persons to operate this implement who have fully read and comprehended this manual, who have been properly trained in the safe operation of this implement, and who are age 16 or older. Serious injury or death can result from the inability to read, understand, and follow instructions provided in this manual.
- Never carry riders on the implement or tractor. Riders can obstruct the operator's view, interfere with control of the equipment, be pinched by moving components, become entangled in rotating components, be struck by objects, be thrown or fall from the equipment, etc.
- Do not use implement as a man lift, work platform or as a wagon to carry objects. It is not properly designed or guarded for this use.
- Do not use implement to tow other equipment unless it is designed with a tow hitch. Doing so can result in loss of control and damage the equipment.
- Always follow "Tractor Shutdown Procedure" provided in this manual before dismounting the tractor.
- Perform scheduled maintenance. Check for loose hardware, missing parts, broken parts, structural cracks, and excessive wear. Make repairs before putting implement back into service.

## Section 5: Operating Procedures

- *Do not exceed rated cutting capacity of your cutter. See specifications & capacities for specified cutting capacity. Exceeding rated cutting capacity can damage drive components, cutter blades, and deck components.*
- *Buildup of debris around moving components and gearboxes is a fire hazard. Keep rotating parts and gearboxes free from debris to avoid serious injury and property damage.*
- *Improper oil level can cause bearing failure and be a fire hazard. Maintain proper gearbox oil level to avoid serious injury and property damage.*
- *Do not operate a broken or bent driveline. Such a driveline will break apart while rotating at high speeds and can cause serious injury or death. Always remove the implement from use until the damaged driveline can be repaired or replaced.*

### Tractor Shut Down Procedure

The following shut down procedure should always be followed before operator dismounts from the tractor.

1. Reduce tractor engine speed to an idle, disengage power take-off, and park on a level surface.
2. Fully retract extension arm cylinder and operate deck pivot cylinder to rotate deck down to horizontal.
3. Lower 3-point arms until deck is on the ground.
4. Place tractor gear selector in park or set park brake, turn off engine, and remove switch key to prevent unauthorized starting.
5. Wait for all components on the cutter to come to a complete stop before leaving the operator's seat.

### Inspection of Tractor & Cutter

Make the following inspections after attaching cutter to the tractor. See “**Tractor Hook-up**” on page 18 and “**Driveline Installation (Optional)**” on page 20 or “**Speed Increaser Hook-up (Optional)**” on page 23. Make certain power take-off is disengaged and completely stopped.

1. Inspect tractor safety equipment to make sure it is installed and in good working condition.
2. Check ROPS (Roll Over Protective Structure) and operator protective shield to make sure both are in good working condition. See “**Protective Shield (Accessory)**” on page 28.
3. Inspect cutter safety equipment to make sure it is installed and in good working condition.
4. Check cutter initially and periodically for loose bolts and pins. Refer to “**Torque Values Chart for Common Bolt Sizes**” on page 54.
5. Check optional driveline or optional power take-off mounted speed increaser/pump as follows:
  - Optional Driveline:**
    - Make sure the driveline yokes are securely connected to the tractor power take-off shaft and cutter gearbox shaft.
    - Check driveline shields to make sure they are in good working condition and in place.
  - Optional power take-off Mounted Speed Increaser/Pump:**
    - Check power take-off mounted pump to make certain it is secured to the tractor power take-off shaft.
    - Make sure pump safety chain is properly hooked to the tractor.
6. Lubricate cutter as needed. Refer to “**Lubrication Points**” on page 44.
7. Check all hoses to be sure they will not pinch or make contact with driveline or tractor.
8. Inspect Hydraulic hoses for wear, damage, and hydraulic leaks. See “**Avoid High Pressure Fluids Hazard**” on page 3. Replace damaged and worn hoses with genuine Land Pride parts.
9. Carefully raise and lower implement to ensure drawbar, tires, and other equipment on the tractor do not contact cutter frame or optional driveline.
10. Hook transport safety chain to the deck hook. Refer to “**Hook-up Transport Safety Chain**” on page 37 for detailed instructions.
11. Continue on next page.

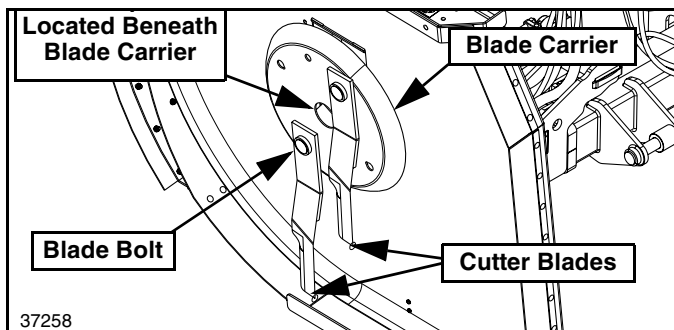

**Check Cutter Blades**  
Figure 5-1

### **WARNING**

To avoid serious injury or death:

The following operational procedures should be carried out by the tractor operator. Other persons should not be in the area. All cutter operations including field set-up should be stopped when other persons are in the vicinity.

Refer to Figure 5-1:

12. Make the following checks with power take-off disengaged, blade rotation stopped, deck rotated up, 3-point arms lowered until deck is resting on the ground, and transport safety chain hooked to the deck.
  - Check for and remove foreign objects wrapped around cutter blades and blade spindle.
  - Check blades to be sure they are not locked (overlapped) together.
  - Ensure that both blade bolts and center blade carrier hub nuts are tight. Refer to “**Additional Torque Values**” on page 54 for torque values.
  - Check cutter blades for nicks, bends, breaks, cracks, and sharpness. Replace or sharpen blades as required. Refer to “**Cutter Blade Maintenance**” on page 42.

### Blade Operation Inspection

#### **DANGER**

To avoid serious injury or death:

- Cutter blades can be rotating with deck off the ground and at all kinds of angles to the ground. Keep all personnel away while cutter blades are rotating. Rotating cutter blades can cause serious injury or death.
- Tractor power take-off shaft shield, driveline shields, and gearbox shaft shields must be installed and in good working condition to avoid driveline entanglement and projectiles flying off of the driveline.
- Do not use a power take-off adapter. The adapter will increase strain on the tractor’s power take-off shaft causing possible damage to shaft and driveline. It will also defeat the purpose of the tractor’s power take-off shield.

#### **WARNING**

To avoid serious injury or death:

- Always follow “Tractor Shutdown Procedure” provided in this manual before dismounting the tractor.
- Stop power take-off immediately if vibration continues after a few revolutions during start-up and anytime thereafter. Wait for all components to come to a complete stop before dismounting from tractor to check for probable causes. Make necessary repairs and adjustments before continuing.
- Some tractors are equipped with two power take-off speeds. Be certain your tractor’s power take-off is set at the implement’s rated power take-off speed or equipment breakage may result. DB Series are rated for 540 rpm and DBM Series are rated for 1000 rpm.

**IMPORTANT:** Read all “**Safety Information**” starting on page 1 before operating the cutter.

**IMPORTANT:** Before engaging tractor power take-off, make sure reservoir is full of hydraulic oil, shut-off valve is fully open, and speed increaser/pump hydraulic plumbing is configured correctly. See “**Section 3: Hydraulic Plumbing**” on page 29.

1. Make sure cutter blades are not locked against each other. Refer to step 11 on page 35.
2. Set tractor control lever for deck pivot cylinder in self-cancel detent and fully retract deck pivot cylinder.
3. Lower 3-point arms until deck pivot joint is resting on the ground.
4. Place tractor gear selector in park or set park brake, turn off engine, and remove switch key to prevent unauthorized starting.
5. Unhook transport safety chain and store on storage hook. See “**Unhook Transport Safety Chain**” on page 37.
6. Return to the tractor and raise/lower 3-point arms until deck is about 6" off the ground.
7. Extend/retract deck pivot cylinder until deck is level with the ground.
8. Set tractor control lever for the deck pivot cylinder in float detent if gauge wheel is included and self-cancel detent if gauge wheel is not included.
9. Start tractor and set throttle speed just above idle. Use tractor’s power take-off soft start option if available. Slowly engage power take-off to get blades rotating. (Also see “**Blade Engagement**” on page 38.)
10. Initial start-up vibration is normal and should stop after a few revolutions. Stop power take-off rotation immediately if vibration continues.
11. Once cutter is running smoothly, increase throttle to full power take-off speed. If cutter vibrates excessively for 3 seconds at full speed then immediately disengage power take-off, shut tractor down, and remove switch key.



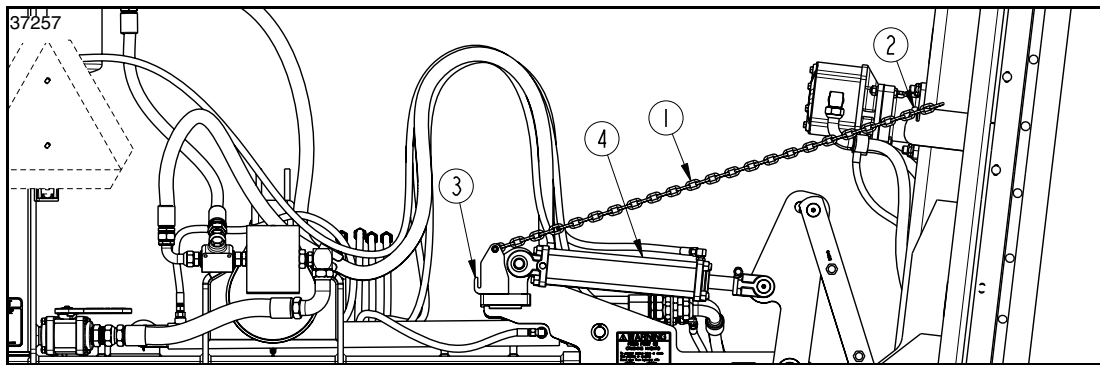

Transport Safety Chain Shown in Transport  
Figure 5-2

12. Check blades for a locked-up situation. Unlock blades if locked-up. Refer to step 11 on page 35.
13. Check for other probable causes such as broken or bent blades, loose blades, loose gearbox mounting bolts, and bent driveline.
14. Taking proper precautions, make necessary repairs and adjustments.
15. Repeat steps 1 to 13 above to make certain vibration problems are fixed before putting cutter back into service.

### Hook-up Transport Safety Chain

Refer to Figure 5-2:

#### DANGER

To avoid serious injury or death:

- Always hook transport safety chain (#1) to deck hook (#2) when deck is rotated up for inspection, when transporting, and when parking tractor and cutter with deck rotated up. Never go near the deck underside or deck pivot points until after it is secured with the transport safety chain, and never rely on hydraulics to secure the deck rotated up.
- Tractor control lever for the deck pivot cylinder must not be in float detent position while hooking-up transport safety chain, while chain is hooked to the deck hook, and when unhooking the transport safety chain. Otherwise, the deck could fall suddenly causing serious injury or death.

Refer to Figure 5-2 on page 37:

1. If engaged, disengage power take-off, park on a level surface, and place tractor in park or set park brake.
2. Fully retract extension arm cylinder.

**IMPORTANT:** Set tractor control lever for deck pivot cylinder (#4) in self-cancel detent before hooking up transport safety chain.

3. Fully retract deck pivot cylinder (#4) to rotate deck completely up.

4. Lower 3-point arms until deck pivot joint is resting on the ground.
5. Turn off engine and remove switch key to prevent unauthorized starting.
6. Hook transport chain (#1) to deck hook (#2).

### Unhook Transport Safety Chain

Refer to Figure 5-2:

**IMPORTANT:** Transport safety chain should remained hooked to the deck until ready to lower the deck down.

**IMPORTANT:** Tractor control lever for deck pivot cylinder (#4) must remain in self-cancel detent when unhooking transport safety chain.

1. Park on a level surface and place tractor in park or set park brake
2. Fully retract deck pivot cylinder (#4) to rotate deck completely up.
3. Lower 3-point arms until deck pivot joint is resting on the ground.
4. Turn off engine and remove switch key to prevent unauthorized starting.
5. Unhook transport safety chain (#1) from deck hook (#2). Do not force safety chain (#1) off of deck hook (#2). If safety chain does not remove easily, investigate cause and correct the problem before continuing. Make sure tractor control lever is set to self-cancel detent.
6. Once unhooked, store transport safety chain (#1) in storage hook (#3) by hooking the chain 15" from its free end. The chain should hang from the hook in 3 segments that are approximately equal in length.
7. Return to the tractor and extend deck pivot cylinder to rotate deck down.
8. If deck is equipped with a gauge wheel, place tractor control lever in float detent position before traveling with deck supported by the gauge wheel.

## Section 5: Operating Procedures

## Transporting

 **WARNING**

To avoid serious injury or death:

- When traveling on roadways, travel in such a way that other vehicles may pass you safely. Use LED lights, clean reflectors, and a slow moving vehicle sign that is visible from the back to warn operators in other vehicles of your presence. Always comply with all federal, state, and local laws.
- Reduce ground speed when turning and leave enough clearance to avoid making contact with obstacles such as buildings, trees, fences, etc. Making contact can result in equipment damage and cause serious injury or death.
- Select a safe ground speed when transporting. Never travel at a speed which does not allow adequate control of steering and stopping, and never exceed 20 mph (32.2 km/h) with attached equipment. Rough terrain requires a slower speed.
- Transport on public roadways with your tractor's SMV sign mounted on the back of the Ditch Bank Cutter. It is possible for the Ditch Bank Cutter to block viewing of the sign by approaching vehicles if mounted on the back of your tractor.
- Always disengage power take-off and wait for driveline to stop rotating before raising implement to transport position.

**IMPORTANT:** The SMV sign should not be used when transporting equipment on a truck or trailer exceeding speeds of 25 mph. Cover or remove the SMV sign when hauling the Ditch Bank Cutter.

1. Follow all “**Hook-up Transport Safety Chain**” instructions on page 37 before transporting cutter from one site to another.
- Refer to Figure 5-3:**
2. Relocate SMV Safety sign (#1) from back of your tractor to the SMV mounting bracket (#2) on the back of the Ditch Bank Cutter. If needed, a SMV sign can be purchased from your nearest Land Pride dealer. Refer to “**Slow Moving Vehicle Sign (Accessory)**” on page 27.
  3. Start tractor and raise 3-point arms up.
  4. Select a safe ground travel speed when transporting from one area to another. Do not exceed 20 miles per hour travel speed.
  5. Reduce tractor ground speed when turning and leave enough turning clearance so cutter does not contact obstacles such as buildings, trees or fences.
  6. Shift tractor to a lower gear when traveling over rough or hilly terrain.
  7. When traveling on roadways, transport in such a way that faster moving vehicles may pass you safely.

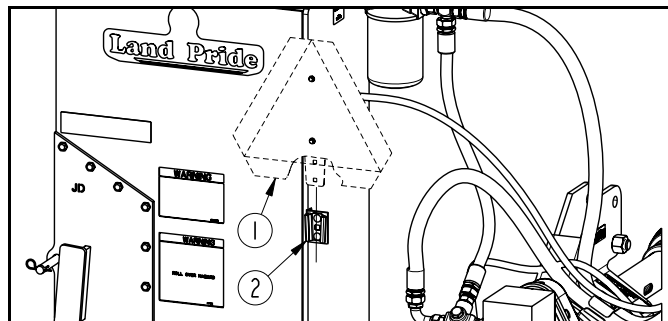

Relocate SMV Sign to Back of Cutter  
Figure 5-3

## Blade Engagement & Disengagement

Cutter blades can lock-up against each other during start-up and shut-down especially if tractor's power take-off engagement is “**INSTANT ON**” and “**INSTANT OFF**”. Following “**Blade Engagement**” and “**Blade Disengagement**” instructions below will help eliminate blade lock up.

 **DANGER**

To avoid serious injury or death:

Cutter blades can be rotating with deck off the ground at all kinds of angles to the ground. Keep all personnel away while cutter blades are rotating. Rotating cutter blades can cause serious injuries or death.

### Blade Engagement

1. Increase throttle speed just enough to get the blades rotating without stalling tractor while slowly engaging power take-off. Use tractor's power take-off soft start option if available.
2. Ensure cutter is rotating and that the cutter is not vibrating excessively after ramping up to power take-off speed for at least 3 seconds. If excessive vibration continues after 3 seconds at full power take-off speed, disengage power take-off immediately, shut down tractor, remove switch key, and wait for blades to come to a complete stop.
3. Check cutter blades for a lock-up situation.
4. Cutter should be supported with blocks before working under the unit. Unlock blades, remove support blocks, and repeat “**Blade Engagement**” instructions.

### Blade Disengagement

1. Slowly decrease throttle speed until engine idle speed is reached and then disengage power take-off.
2. If dismounting tractor, be sure to follow “**Tractor Shut Down Procedure**” on page 35.

## Section 5: Operating Procedures

## Field Set-up &amp; Operation

 **DANGER**

To avoid serious injury or death:

- Tractor power take-off shaft shield, driveline shields, and gearbox shaft shields must be installed and in good working condition to avoid driveline entanglement and projectiles flying off of the driveline.
- Rotary Cutters have the ability to discharge objects at high speeds; therefore, the use of front and rear safety guards is mandatory with this cutter. Stop blade rotation if a bystander is in or around the area.
- Do not operate cutter after dark without working lights. The equipment can hit unseen objects or be hit by other vehicles. The operator can lose control of the tractor and cutter causing a wreck or roll-over.

 **WARNING**

To avoid serious injury or death:

- Operating instructions in this manual must be carefully read and fully understood. You are the tractor operator and are therefore responsible for the safe operation of this unit. All other persons must be cleared of the area. Cutting operations must be stopped when in the vicinity of other persons.
- Hydraulic fluid under high pressure can penetrate the skin and/or eyes causing a serious injury. Wear protective gloves and safety glasses or goggles when working with hydraulic systems. Use a piece of cardboard or wood rather than hands when searching for leaks. A doctor familiar with this type of injury must treat the injury within a few hours or gangrene may result. **DO NOT DELAY.**
- Do not operate cutter under any terrain conditions that would place tractor at an angle exceeding 30 degrees either front-to-rear or left-to-right. Make sure adequate ballast weights are provided on both the front of tractor and left of tractor and left-hand side of Ditch Bank Cutter to assure tractor stability.
- Do not operate cutter going too fast for the terrain. Slow down if obstacles are present that the cutter can hit and jerk the tractor around. Slow down if terrain is rough causing tractor to bounce. Either situation can cause operator to lose control and result in serious injury or death.
- Do not exceed rated cutting capacity of your cutter. See specifications & capacities for specified cutting capacity. Exceeding rated cutting capacity can damage drive components, cutter blades, and deck components.
- Buildup of debris around moving components and gearboxes is a fire hazard. Keep rotating parts and gearboxes free from debris to avoid serious injury and property damage.
- Improper oil level can cause bearing failure and be a fire hazard. Maintain proper gearbox oil level to avoid serious injury and property damage.
- Avoid catching hydraulic hoses on brush, posts, tree limbs, and other protrusions that could damage and/or break them.

- Some tractors are equipped with two power take-off speeds. Be certain your tractor's power take-off is set at the implement's rated power take-off speed or equipment breakage may result. DB Series are rated for 540 rpm and DBM Series are rated for 1000 rpm.

1. Remove and stow transport safety chain before extending extension arm or rotating deck down. See “Unhook Transport Safety Chain” on page 37.
2. Extend arm cylinder and deck pivot cylinder as follows:

**Deck without gauge wheel:**

- a. Make certain tractor control levers are set to self-cancel detent.
- b. Extend arm cylinder until positioned as needed.
- c. Extend deck pivot cylinder until deck is parallel to the ground.
- d. Lower tractor 3-point arms until deck is at its cutting height.

**Deck with gauge wheel:**

- a. Make certain tractor control levers are set to self-cancel detent.
- b. Adjust gauge wheel as needed. Refer to “Section 4: Adjustments” on page 30.
- c. Extend arm cylinder until deck is positioned as needed.
- d. Extend deck pivot cylinder until deck is parallel to the ground.
- e. Lower tractor 3-point arms until deck is supported by the gauge wheel.
- f. Set control lever for deck pivot cylinder in float detent.

**IMPORTANT:** Your cutter is equipped with free swinging cutting blades to reduce shock loads. The blades can lock together in transport. Always check for locked blades before starting to cut.

3. Set tractor throttle to idle or slightly above idle and slowly engage power take-off. Start-up vibration is normal and should stop after a few revolutions of the blade carrier. Stop power take-off rotation if vibration continues. Wait for power take-off to come to a complete stop and then dismount from tractor to check for probable causes such as blades locked together.
4. Once cutter is running smoothly, increase power take-off speed to cutter rated speed. Stop power take-off immediately if vibration occurs during operation. Wait for the power take-off to come to a complete stop and then dismount from the tractor to check for probable causes.
5. Optimum ground speed will depend on density of material being cut, terrain, and operator skill. If in doubt, change gears to reduce tractor ground speed to a more comfortable speed.

## Section 5: Operating Procedures

### Unhook Ditch Bank Cutter

#### Initial Preparation

1. See “**Long Term Storage**” on page 43 before parking Ditch Bank Cutter for a long period.
2. Disengage power take-off, park on a flat, level, hard surface, and place gear selector in park or in neutral with park brake set.

**IMPORTANT:** Make sure control levers for both cylinders are set to self-cancel detent.

3. Fully retract extension arm cylinder and deck pivot cylinder.
4. Lower 3-point arms until deck is several inches above ground.
5. Shut engine off, remove switch key, and wait for power take-off to stop before dismounting tractor.
6. Remove detent pin and lower parking stand to support cutter frame. Replace detent pin.
7. Unhook transport safety chain and stow on storage hook. Refer to “**Unhook Transport Safety Chain**” on page 37

**IMPORTANT:** For stability, unhook cutter with deck rotated parallel with the ground. The cutter is less stable and can fall over when unhooked folded in transport position.

8. Restart tractor and extend deck pivot cylinder until deck is parallel with the ground.
9. Lower 3-point arms until cutter is supported by the park stand and deck skid shoes.

#### Unhook Hydraulic Hoses

1. Move hydraulic control levers back and forth several times to relieve all hydraulic pressure in hydraulic hoses.
2. Disconnect hydraulic hoses from tractor duplex outlets.
3. Wrap hydraulic hoses around Ditch Bank Cutter frame for storage and to keep dirt away from quick disconnect couplings.

#### Unhook Driveline Option

1. Pull back on driveline pull collar and hold while pulling driveline yoke from tractor power take-off shaft.
2. Collapse driveline by pushing tractor end of driveline towards the Ditch Bank Cutter.
3. Support collapsed driveline off the ground to keep dirt away from driveline pull collar and bearings.

#### Unhook Speed Increaser/Pump Option

1. Unhook safety chain from tractor.
2. Pull back on pull collar and hold while pulling speed increaser/pump from tractor power take-off shaft.

3. Store speed increaser/pump on support blocks to keep unit out of the dirt.

#### Unhook 3-Point Hitch Option

1. Remove top center hitch pin keeper and hitch pin. If provided, place center 3-point link in tractor’s holding clip.
2. Remove linchpins and hitch pins from lower 3-point lift arms.
3. Restart tractor and drive forward several feet while making sure lower 3-point arms do not catch on implement while pulling away.
4. Place gear selector in park or set park brake, shut tractor engine off, remove switch key, and dismount tractor.
5. Reinstall hitch pins, linchpins, and hair pin cotter pins in the Ditch Bank Cutter hitch for safe keeping.

#### Unhook Quick Hitch Option

**NOTE:** Refer to Quick Hitch Operator’s Manual for unhooking instructions specific to your Quick Hitch.

1. Restart tractor and lower 3-point lift arms until auto-lock hooks are below implement hitch pins and upper hook is below implement upper hitch point.
2. Slowly drive tractor forward several feet while watching to make sure Quick Hitch does not catch on implement while pulling away.
3. Place gear selector in park or set park brake, lower 3-point arms down, shut tractor engine off, and remove switch key before dismounting tractor.

#### Relocate SMV Sign

**Refer to Figure 5-3 on page 38:**

1. Remove SMV sign (#1) from mounting bracket on the back of the Ditch Bank Cutter.
2. Reinsert SMV Sign in the mounting bracket on the back of your tractor.



Section 6: Maintenance & Lubrication

**General Maintenance Information**

Proper servicing and adjustments are key to the long life of any implement. With careful inspection and routine maintenance, you can avoid costly downtime and repair. Check all bolts and pins after using the cutter for several hours and on a regular basis thereafter to ensure they are tight and secured. Replace worn, damaged, or illegible safety labels by obtaining new labels from your Land Pride dealer.

**WARNING**

To avoid serious injury or death:

- Always shut tractor down using “Tractor Shutdown Procedure” provided in this manual before servicing, adjusting, cleaning, or maintaining this implement.
- Perform scheduled maintenance. Check for loose hardware, missing parts, broken parts, structural cracks, and excessive wear. Make repairs before putting implement back into service.
- Do not alter implement or replace parts on the implement with other brands. Other brands may not fit properly or meet OEM (Original Equipment Manufacturer) specifications. They can weaken the integrity and impair the safety, function, performance, and life of the implement. Replace parts only with genuine OEM parts.
- Buildup of debris around moving components and gearboxes is a fire hazard. Keep rotating parts and gearboxes free from debris to avoid serious injury and property damage.
- Improper oil level can cause bearing failure and be a fire hazard. Maintain proper gearbox oil level to avoid serious injury and property damage.

**Hydraulic System**

One of the most important things you can do to prevent hydraulic system problems is ensure that your tractor's reservoir remains free of dirt and contamination.

Use a clean cloth to wipe hose ends before attaching them to your tractor. Replace your tractor's hydraulic filter element at the prescribed intervals. These simple maintenances will go a long way to prevent occurrence of control valve and hydraulic cylinder problems.

**Land Pride Skid Shoe Replacement Parts** 24623

Item	Part No.	Part Description
1	326-221D	SKID SHOE
2	802-603C	PLOW BOLT, 3/8" - 16 x 1" grade 5

Wing Skid shoe  
Figure 6-1

**Skid Shoes**

Refer to Figure 6-1:

**WARNING**

To avoid serious injury or death:

Excessive wear on skid shoes can damage side panels, cause inadequate operation of cutter, and create a safety hazard. Always replace skid shoes at the first sign of wearing thin.

Inspect skid shoes at the beginning of each cutting season. Check all skid shoes weekly for wear and replace if necessary. Original material thickness is 1/4". They should be replaced when the material thickness is less than 1/8" at any point. They are interchangeable from left to right.

Order only genuine Land Pride parts from your local Land Pride dealer.

Replace wing skid shoes as follows:

1. Remove 3/8" hex whiz nuts (#3), 3/8" plow bolts (#2), and skid shoe (#1) as shown.
2. Plow bolts should be checked for wear and replaced if necessary.
3. Attach new skid shoe (#1) to cutter with existing 3/8" plow bolts (#2) and secure with 3/8" hex whiz nuts. Torque to 31 ft. lbs.
4. Repeat on opposite side.

## Section 6: Maintenance & Lubrication

### Cutter Blade Maintenance

#### DANGER

To avoid serious injury or death:

- Always secure equipment with solid, non-concrete supports before working under it. Never go under equipment supported by concrete blocks or hydraulics. Concrete can break, hydraulic lines can burst, and/or hydraulic controls can be actuated even when power to hydraulics is off.
- Always disconnect driveline from the tractor and secure implement in the up position with solid, non-concrete supports before servicing the underside. A person can become entangled in the drivetrain if the tractor is started and power take-off is engaged or crushed by an unsupported implement.

#### WARNING

To avoid serious injury or death:

- Do not operate cutter with blades that are out-of-balance, bent, excessively worn, excessively nicked, or with blade bolts that are excessively worn. Such blades can break loose at high speeds.
- Do not attempt to straighten a bent blade or weld on a blade. Do not attempt to modify a blade such as hard surfacing, heat treating, cold treating, or by any other method. Always replace blades with new Land Pride blades to assure safety.

### Inspect Cutter Blades

Refer to Figure 6-2 on page 43:

Inspect cutting blades before each use. Make certain they are properly installed and are in good working condition. Replace any blade that is damaged, bent, worn, or excessively nicked. Small nicks can be ground out.

**IMPORTANT:** Replace cutting blades with genuine Land Pride blades only. Blades must be replaced in sets. Not replacing blades in sets will result in an out-of-balance condition that could contribute to premature bearing wear/breakage and/or structural cracks in gearbox and/or deck.

1. Place tractor gear selector in park or set park brake, turn off engine, and remove switch key to prevent unauthorized starting.
2. Disconnect main driveline from tractor power take-off and secure cutter deck in the up position with solid supports before servicing underside of cutter.
3. Inspect cutting blades. Make certain they are properly installed and are in good working condition.
4. Replace any blade that is damaged, bent, worn, or excessively nicked. Small nicks can be ground out when sharpened. See “**Cutter Blade Removal**”, “**Blade Sharpening**”, and “**Blade Installation**” on page 42 for detailed instructions.

### Cutter Blade Removal

Refer to Figure 6-2:

1. Make sure tractor is shut down properly. Refer to steps 1 & 2 on page 42.
2. Remove access cover (#6).
3. Rotate blade bolt (#1) until in alignment with access hole “A”.
4. Unscrew locknut (#3) to remove cutting blade (#5). Blade bolt (#1) is keyed and will not turn freely.

### Blade Sharpening

Both blades should be sharpened at the same angle as the original cutting edge and must be replaced or re-ground at the same time to maintain proper balance in the cutting unit. The following precautions should be taken when sharpening blades:

1. Do not remove more material than necessary.
2. Do not heat and pound out a cutting edge.
3. Do not grind blades to a razor edge. Leave a blunt cutting edge approximately 1/16" thick.
4. Always grind cutting edge so end of blade remains square to cutting edge and not rounded.
5. Do not sharpen back side of blade.
6. Both blades should weigh the same with not more than 1 1/2 oz. difference. Unbalanced blades will cause excessive vibration which can damage gearbox bearings and create structural cracks.

### Blade Installation

Refer to Figure 6-3:

1. Make sure tractor is shut down properly. Refer to steps 1 & 2 on page 42.
2. Carefully check cutting edges of blades in relation to blade carrier rotation to ensure correct blade placement. Blade Rotation is clockwise with cutting edge leading. Airfoil (lift) must be oriented towards the top of the deck.

Refer to Figure 6-2:

#### WARNING

To avoid serious injury or death: A locknut that has been removed can lose its thread locking properties. Reusing a used locknut can result in a thrown blade. Always use a new locknut when installing blades.

**IMPORTANT:** Examine blade bolts (#1) and flat washers (#2) for excessive wear and replace if worn.

3. Insert blade bolt (#1) through blade (#5), dish pan (#4), and flat washer (#2). Secure blade with a **new locknut (#3)** and torque to 450 ft-lbs.
4. Replace access cover (#6) and secure with flat washers (#7), lock washers (#8), and wing nuts (#9). Tighten wing nuts until lock washers are flattened.

## Section 6: Maintenance & Lubrication

5. If replacing dishpan (#4), castle nut (#10) on gearbox output shaft should be torqued to 550 ft-lbs. minimum and secured with cotter pin (#11) with both legs bent opposite directions around the nut.

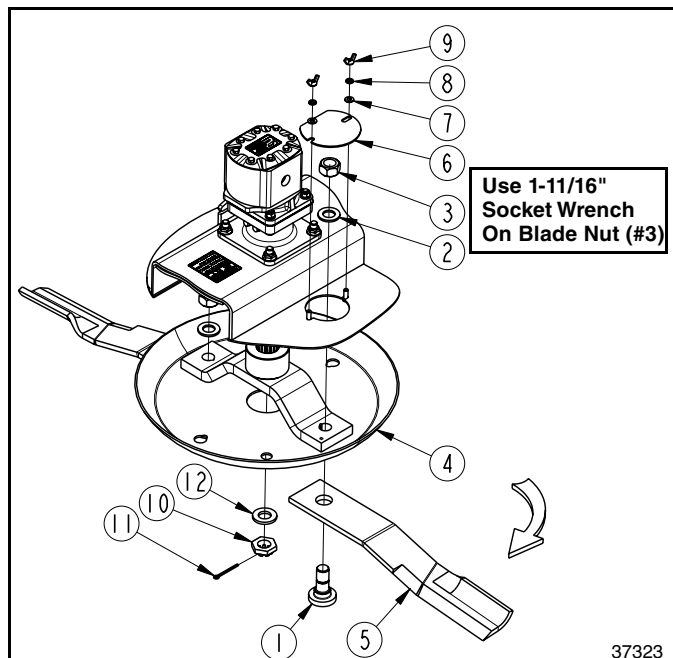

### Land Pride Cutter Blade Parts

Item	Part No.	Part Description
	318-586A	BLADE BOLT KIT (Includes items 1, 2, & 3 below)
1	802-277C	BLADE BOLT 1 1/8-12 x 3 7/16 WITH KEY
2	804-147C	WASHER FLAT 1 HARD ASTM436
3	803-170C	NUT HEX TOP LOCK 1 1/8-12 PLATE
4	316-124H	DISHPAN WELDMENT SPCL-HUB
5	820-112C	CUTTER BLADE 1/2 x 4 x 25 CW

**Ditch Bank Cutter Blade Assembly**  
Figure 6-2

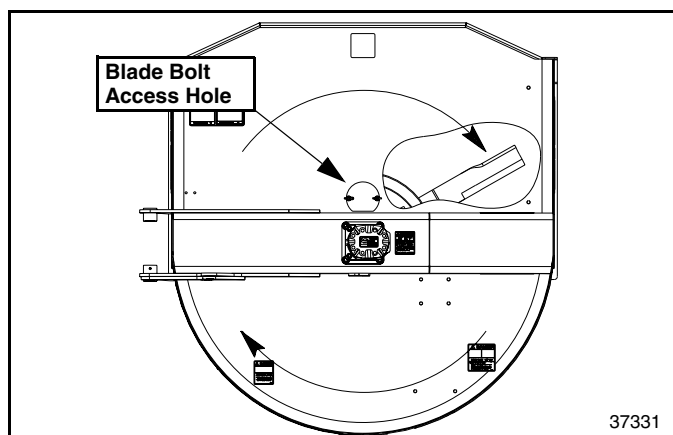

**Blade Rotation (Viewed From the Top)**  
Figure 6-3

## Long Term Storage

Clean, inspect, service, and make necessary repairs to the implement when storing it for long periods and at the end of the season. This will help ensure the unit is ready for field use the next time you hook-up to it.

1. Clean extension arm and inside surfaces of support boom of grass and other debris. See “**Extension Arm**” on page 45 of detailed instructions.
2. Clean off any dirt or grease that may have accumulated on the deck, deck motor, and on any of the moving parts. Scrape off compacted dirt from the bottom of the deck and then wash the surface thoroughly with a garden hose.
3. Check blades and blade bolts for wear and replace if necessary. See “**Cutter Blade Maintenance**” on page 42.
4. Inspect for loose, damaged, or worn parts and adjust or replace as needed.
5. Lubricate as noted under “**Lubrication Points**” on page 44.
6. Apply a generous coat of lubrication to all 4 sides of the extension arm and all four inside surfaces of the support boom. See “**Extension Arm**” on page 45 of detailed lubricating instructions.
7. A coating of oil may also be applied to the lower deck area and to any exposed hydraulic cylinder rods to minimize oxidation.
8. Store the cutter in a clean, dry place with deck positioned on a flat surface.
9. Disconnect tractor from Ditch Bank Cutter. Refer to “**Unhook Ditch Bank Cutter**” on page 40 for detailed instructions.
10. Replace all damaged or missing decals.
11. Repaint parts where paint is worn or scratched to prevent rust. Aerosol touch-up paint is available from your Land Pride dealer.

### Lubrication Points

<b>Lubrication Legend</b>	Multi-purpose spray lube	Multi-purpose grease lube	Multi-purpose oil lube	<b>50 Hrs</b>	Intervals in hours at which lubrication is required

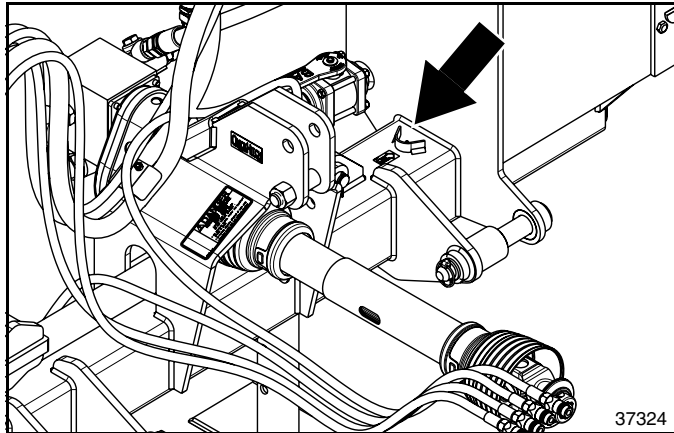

	<b>10 Hours</b>
--	-----------------

#### Extension Arm, Top Side

1 - Zerk

Type of Lubrication: Multi-purpose Grease

Special Instructions: Apply grease with extension arm cylinder fully retracted.

Quantity: 10 pumps

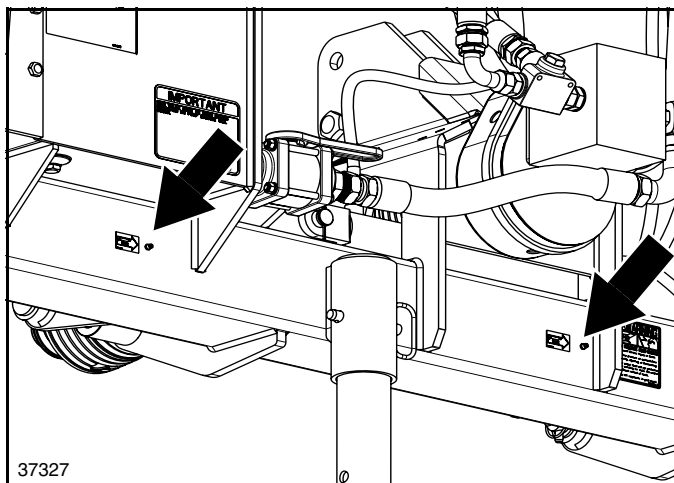

	<b>10 Hours</b>
--	-----------------

#### Extension Arm, Back Side

2- Zerks

Type of Lubrication: Multi-purpose Grease

Special Instructions: Apply grease with extension arm cylinder fully retracted.

Quantity: 10 pumps

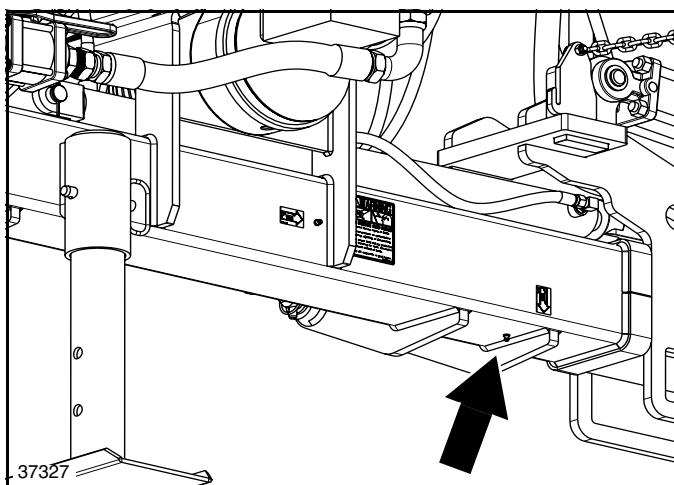

	<b>10 Hours</b>
--	-----------------

#### Extension Arm, Underside

1- Zerk

Type of Lubrication: Multi-purpose Grease

Special Instructions: Apply grease with extension arm cylinder fully retracted.

Quantity: 10 pumps

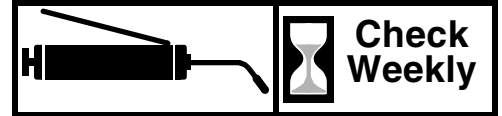
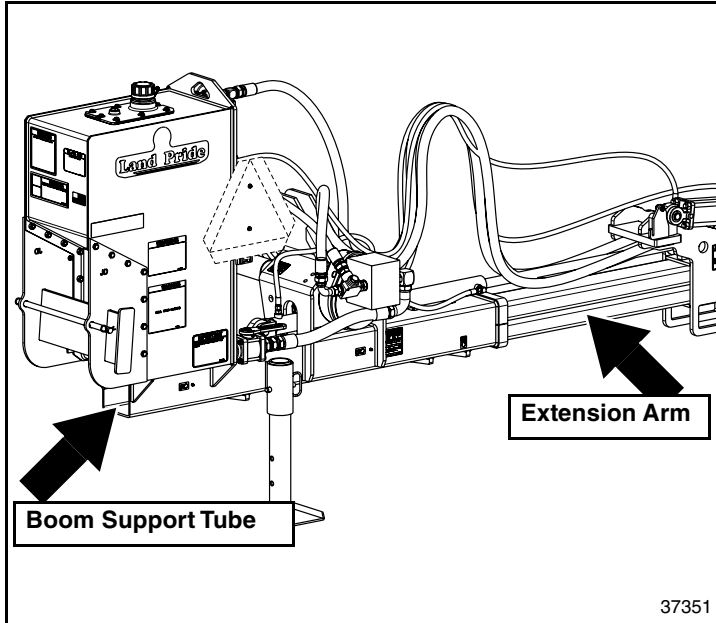

**Extension Arm**

Type of Lubrication: Multi-purpose Grease

**NOTE:**

Fully extend extension arm cylinder.

Clean grass and other debris from extension arm and inside of boom support tube weekly.

Check weekly to ensure exposed arm is greased on all four sides. When needed, add a generous amount of grease to all four sides of the extension arm.

Just beneath the reservoir, check weekly to ensure inside of boom support tube is greased on all four inside surfaces. When needed, add a generous amount of grease to the four inside surfaces.

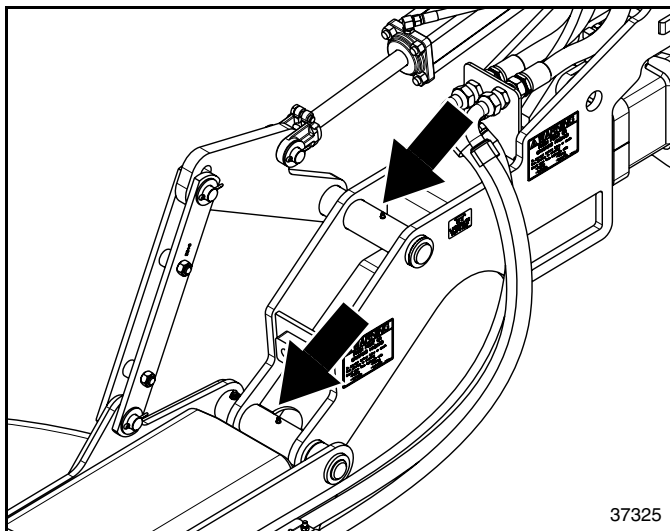

**Deck Pivot Pins**

2 - Zerks

Type of Lubrication: Multi-purpose Grease

Quantity: 2 or 3 pumps

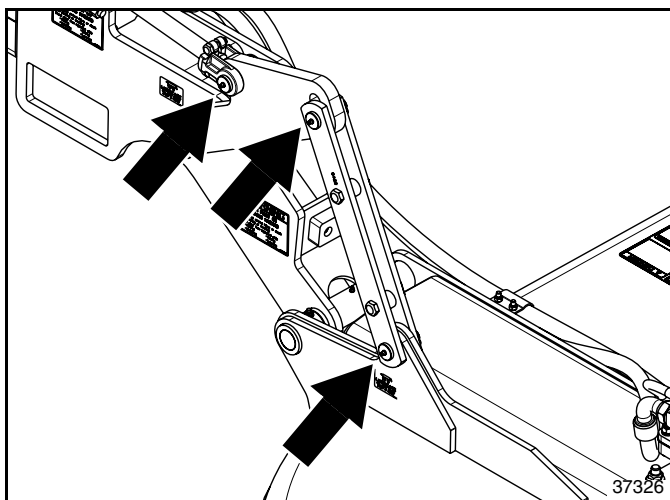

**Deck Pivot Arm & Linkage Pins**

3- Zerks

Type of Lubrication: Multi-purpose Grease

Quantity: 2 or 3 pumps



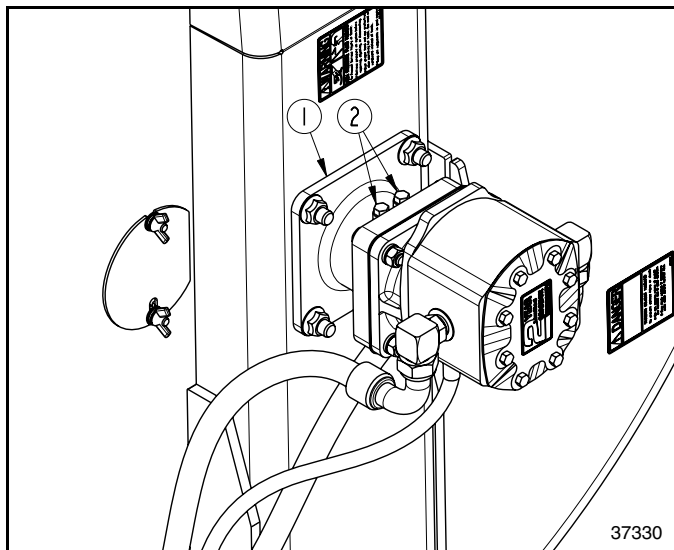

### Motor Spindle Hub

The motor spindle hub (#1), has two cavity plugs (#2) located on one side of the housing.

**NOTE:** To check fluid level, ports (#2) in motor spindle hub must point to the right side of the deck.

1. Disengage Driveline.
2. Position cutter deck in transport position and secure with deck safety chain.
3. Set tractor park brake, shut engine off and remove switch key before continuing.
4. Remove one of the cavity plugs (#2) to check fluid level. Fluid level should be within 1/2" from top of port opening.
5. Add 80-90W EP gearlube as required. Full capacity of motor housing is approximately 1/3 pint.
6. Install cavity plug and tighten.

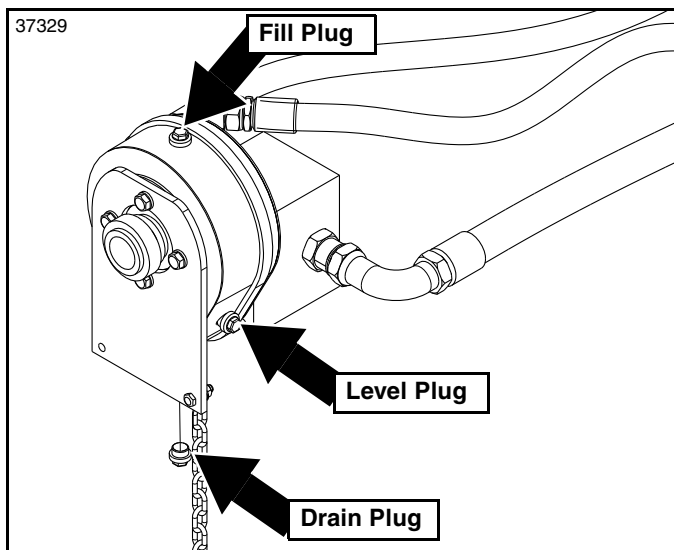

Figure 6-4

### Speed Increaser

*Refer to Figure 6-4: for Tractor Mount*

*Refer to Figure 6-5: for Ditch Bank Mount*

The speed increaser is mounted between the tractor power take-off shaft and hydraulic pump. It is used to increase power take-off speed from 540 rpm or 1000 rpm to approximately 2000 rpm at the pump.

Check oil level by removing the level plug. Oil level should be level with bottom of level plug hole. If oil is below the oil level hole, remove fill plug and add recommend oil through the fill plug hole. When completed, reinstall level plug and fill plug. Tighten both plugs to prevent oil leakage.

Change oil after the first 100 working hours. Thereafter, make successive changes every 1500 hours or every year, whichever comes first. Remove drain plug to drain oil. Be sure to reinstall drain plug and tighten before filling the gearbox. Fill gearbox with 80-90W EP gearlube to the recommended amount provided in box below. When completed, reinstall level plug and fill plug. Tighten both plugs to prevent oil leakage.

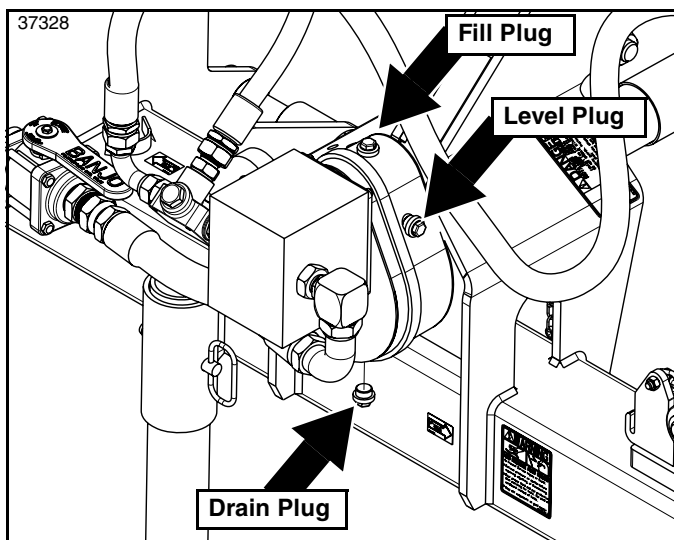

Figure 6-5

**NOTE:** Refer to metal tag on speed increaser for vendor name (BIMA or Comer):

**Tractor mount, refer to Figure 6-4:**

BIMA = 1 1/2 pints

Comer = 2 pints

**Ditch Bank mount, refer to Figure 6-5:**

BIMA = 2 pints

Comer = 1 pint



Section 6: Maintenance & Lubrication

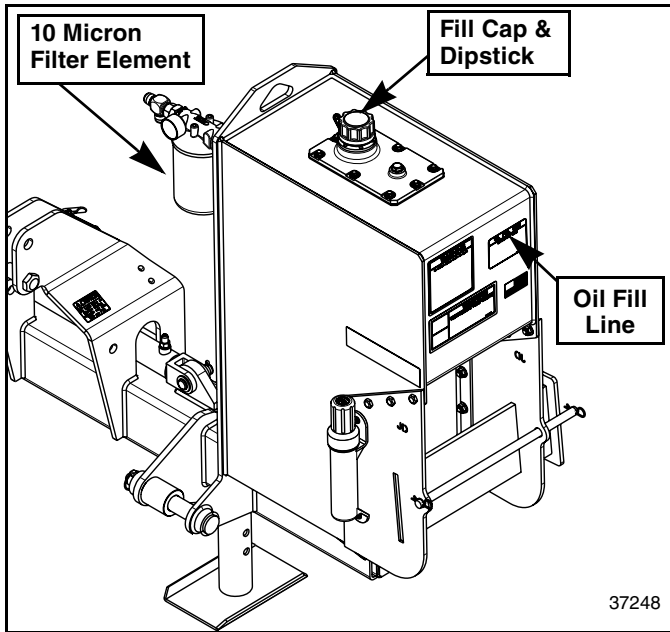

**Hydraulic Reservoir**

The hydraulic reservoir has an effective capacity of 35 gallons. A dipstick located on the fill cap indicates correct reservoir fluid level. Disengage Driveline and shut tractor engine off before checking fluid level. Add hydraulic fluid as needed to reach full mark on dipstick.

A filter mounted on the hydraulic reservoir is used to clean the return hydraulic fluid to the reservoir tank. Replace filter element every 2 years with a conventional 10 micron filter.

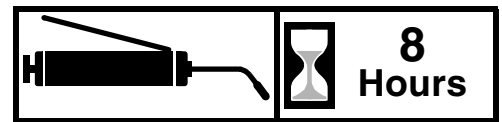
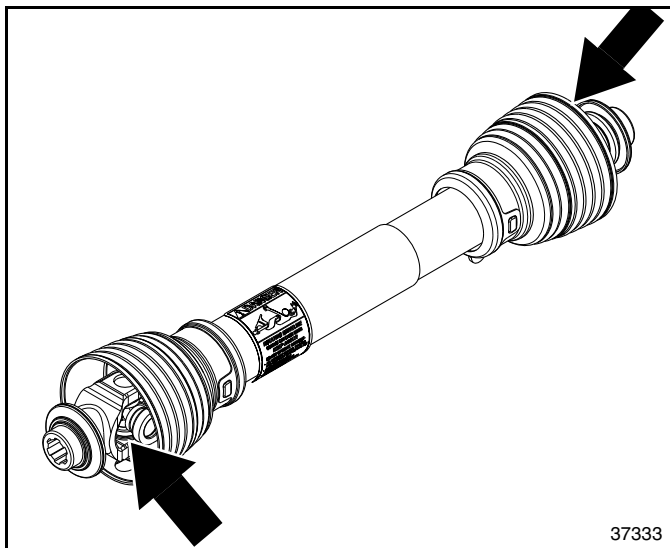

**Driveline Yokes**

2 - Zerks

Type of Lubrication: Multi-purpose Grease

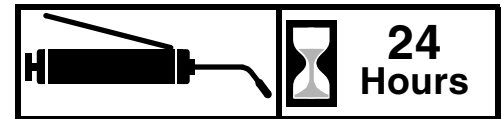
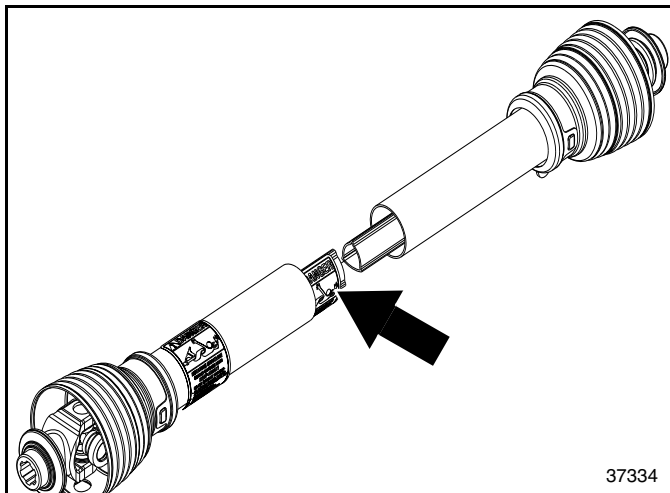

**Driveline Profile**

Around inside of outer profile tube.

Type of Lubrication: Multi-purpose Grease

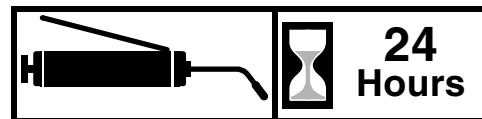
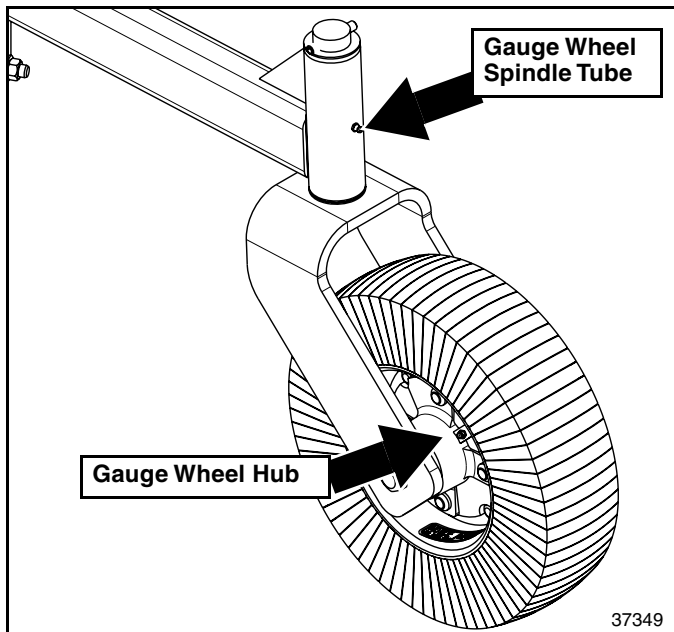

**Gauge Wheel Spindle**

1 - Zerk

Type of Lubrication: Multi-purpose Grease

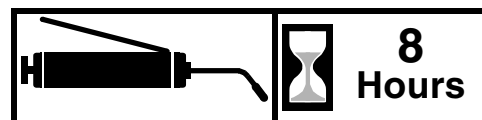

**Gauge Wheel Hub**

1 - Zerk

Type of Lubrication: Multi-purpose Grease

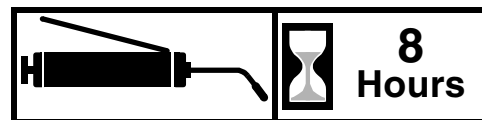
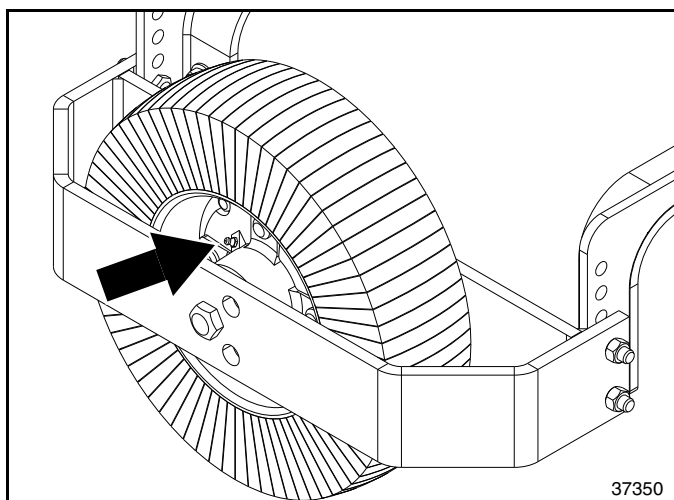

**Side Gauge Wheel Hub**

1 - Zerk

Type of Lubrication: Multi-purpose Grease



This page left blank intentionally.



### DB2660 & DBM2660 Models

Specifications & Capacities		
Tractor horsepower	hp (kW)	75 (55.9) Minimum
Minimum tractor lift capacity	lbs (kg)	2500 (1134)
Minimum tractor weight	lbs (kg)	7000 (3175.1) without added weights
Weight	lbs (kg)	1792 (812.8) With front & rear chain guards, side gauge wheel, Ditch Bank mounted speed increaser, & Case weight hanger. Without fluid in reservoir
Hitch type		Cat. II or Cat. II/III Quick Hitch. Clevis style lower hitch.
Tractor power take-off speed		DB2660 = 540 rpm; DBM2660 = 1000 rpm
Cutting width	in (m)	58 (1.47)
Transport width, minimum	in (m)	10' - 1" (3.07) without gauge wheels
Overall width (fully retracted with optional weight bracket)	in (m)	10' - 3 3/4" (3.14)
Minimum cutting height (Deck level)	in (cm)	2 (5.1) Minimum Maximum is dependent upon 3-point lift height.
Horizontal cutting extension	in (cm)	32 (81.3)
Maximum horizontal reach from center of tractor	in (m)	13'-2" (4.01)
Deck rotation		85° up, 95° down
Blade tip speed	fpm (mps)	15600 (79.2)
Number of blades & size	in (mm)	2, 1/2 (13) x 4 (102)
Blade rotation		Clockwise
Blade bolt	in (cm)	1 1/2 (3.8) With keyway, harden flat washer, and locknut
Dishpan	in (mm)	3/16 (5) X 21 (533) Round, dish-shaped
Cutting capacity	in (cm)	2 (5.1) diameter
Deck thickness	GA (mm)	10 (3.4)
Side skirt thickness	in (mm)	3/16 (5)
Speed Increaser fluid capacity	pints (L)	<b>NOTE:</b> Refer to metal tag on speed increaser for vendor name (BIMA or Comer). <b>Tractor mount, refer to Figure 6-4 on page 46.</b> BIMA = 1 1/2 (.71) Comer = 2 (.95) <b>Ditch Bank mount, refer to Figure 6-5 on page 46.</b> BIMA = 2 (.95) Comer = 1 (.47)
Speed increaser fluid		80-90W EP Gearlube
Hydraulic fluid		Mobilfluid 424 For alternate fluids, search on the web for "Mobilfluid 424" or go to <a href="http://www.mobil.com">www.mobil.com</a>
Reservoir capacity and filter	Gal (L)	35 (132.5) / conventional 10 micron filter
Method to check oil capacity		Dipstick
Hydraulic fluid flow rate	gpm (Lpm)	15 gpm (approx.)
Overload protection		Hydraulic relief valve
Driveline (optional)		ASAE category 4
Skid shoes	in (mm)	2 1/2 (64) Wide x 1/4 (6) thick & replaceable
Gauge wheel (optional)		4 x 8 Laminated tire with greasable caged roller bearings.
Gauge wheel adjustment		Manual
SMV Sign (Accessory)		SMV decal on galvanized steel back sign and plated or galvanized blade mount.

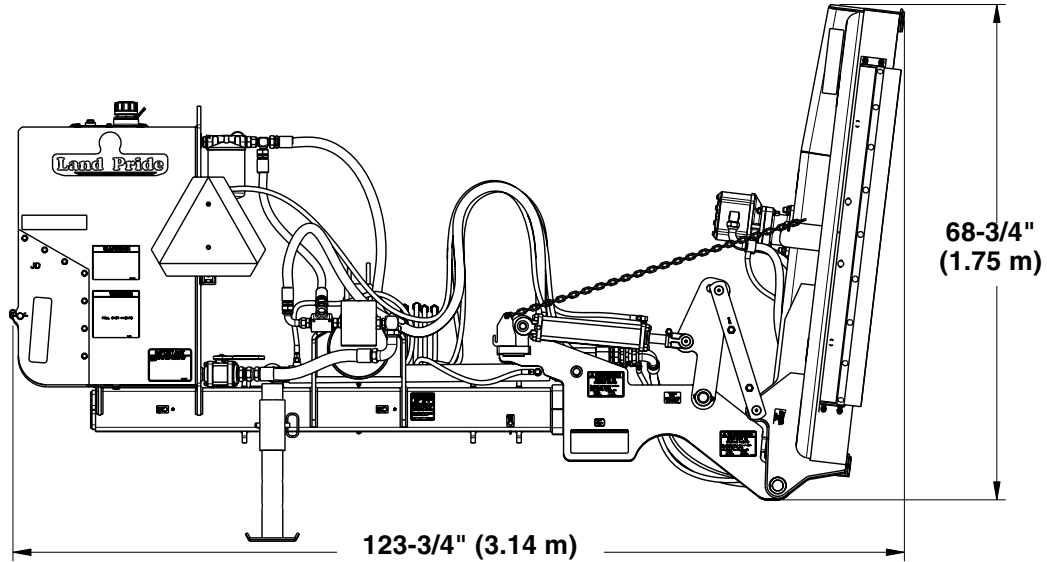

**Deck Folded For Transport**

37342

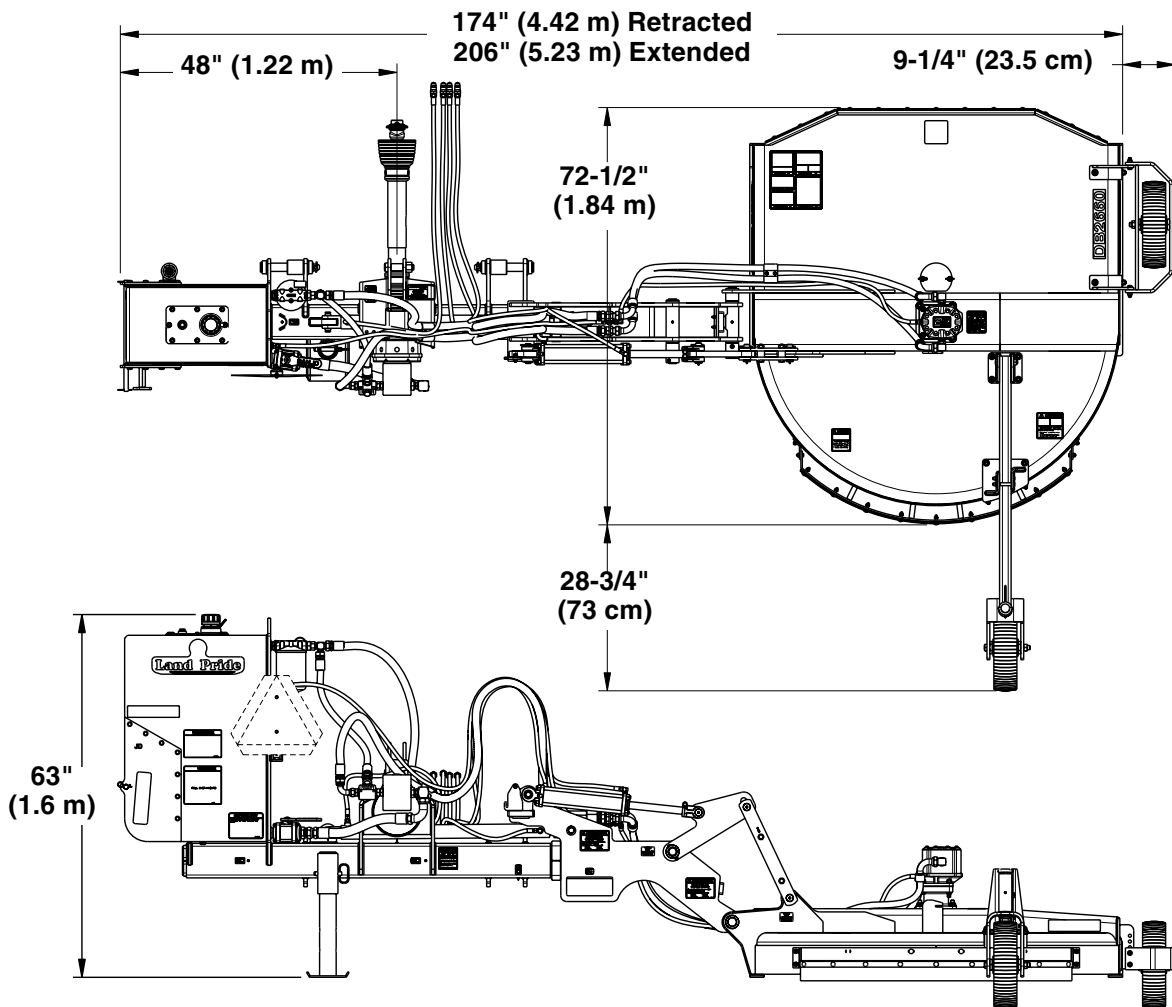

**Deck Rotated Down For Parking Unhooked**

37343



### DB2660 & DBM2660 Models

Features	Benefits
<b>Tractor Horsepower Range</b>	Designed for 75 minimum horsepower tractor with minimum weight of 7,000 lbs.
<b>Gearbox Horsepower Rating</b>	150 horsepower
<b>3 Point Design</b>	Does not require a dedicated tractor. Three point hook up is easy to hook up and remove from tractor.
<b>Cutter Deck Visibility</b>	Visibility of the cutter deck is captured from the operator's seat. Easy to see operation. Operator does not have to look behind.
<b>Factory Assembled</b>	Arrives ready for the customer, saves time and money. (Excluding gauge wheel options and fluids.)
<b>Grease Ports</b>	All grease ports are easily accessible for servicing.
<b>10' Transport Width</b>	Folds up close to the tractor. No weight brackets or decks hanging away from the tractor. Typically, not much wider than the tractor, which means safer transporting.
<b>Extension Arm Design</b>	One cylinder used to adjust extension arm horizontally 32" is easy to operate.
<b>Long Horizontal Reach</b>	Good access for reaching vegetation far away from the tractor.
<b>Above Grade Vertical Reach</b>	Good access for reaching up embankments and cutting low over hanging limbs.
<b>Below Grade Reach</b>	Good access for reaching down embankments.
<b>175 Degree Deck Rotation Angle</b>	Cutter head can be positioned to reach different angles.
<b>Cat. 2 &amp; Cat. 3 with Quick Hitch 540 rpm or 1000 rpm</b>	Fits a wide variety of tractors.
<b>35 Gallon Oil Reservoir</b>	Large reservoir maintains optimum fluid temperatures and also serves as counterweight.
<b>1" Cutting Capacity</b>	Good for trimming brush.
<b>High Blade Tip Speed</b>	15,600 FPM tip speed means cleaner cutting.
<b>One Parking Stand</b>	Easy to adjust 3-point hitch level for unhooking tractor.
<b>In-line Filter</b>	Cleans hydraulic fluid before it re-enters the reservoir.
<b>Shut-off Valve</b>	Permits maintenance with minimum oil loss.
<b>Built-in Auxiliary Weight Rack on Left Side</b>	Suitcase weights can be added to left side for balance. Able to choose the weight bracket to match various types of suitcase weights.
<b>Oil Pressure Gauge</b>	Easily monitor oil pressure for optimum performance of unit.
<b>Pressure Relief Valve</b>	Protects against high hydraulic fluid pressure.
<b>Gauge Wheels Option</b>	Deck floats on gauge wheels eliminating frequent deck positioning and vigilant watch for changes in ground contour under the tractor and/or deck.
<b>SMV Mounting Socket (Standard)</b> <b>SMV Sign (Accessory)</b>	SMV mounting socket receives most SMV signs equipped with a mounting blade for ease of attachment and removal when transporting on a truck or trailer. SMV sign is offered as an accessory when the tractor's SMV sign and mounting blade does not fit the cutter's standard SMV mounting socket.





### Troubleshooting Chart

Problem	Cause	Solution
<b>Motor oil seal leaking</b>	Return line from motor has been pinched or is collapsed.	Replace lower seal of motor. Check motor return hose for kinks.
<b>Spindle hub seal leaking</b>	Return line from motor has been pinched or is collapsed.	Replace lower seal of motor and spindle hub output shaft seal. Check motor return hose for kinks.
<b>Driveline is bent. (NOTE: power take-off tractor hitch shaft should be repaired or replaced if bent)</b>	Contacting drawbar or bottoming out.	Reposition drawbar. Replace power take-off tubes and cut to correct length.
<b>Blades wearing excessively</b>	Cutting on sandy ground.	Raise cutting height.
<b>Blades coming loose</b>	Blade bolts not tightened properly.	Torque blade bolt nuts to 450 ft lbs.
<b>Blades bending</b>	Hitting solid objects.	Thoroughly check the cutting area BEFORE beginning to cut. Be alert during cutting.
<b>Loose blade carrier</b>	Worn spindle hub bearings.	Replace spindle hub bearings and/or shaft.
	Shaft nut loose.	Tighten spindle hub shaft nut to 450 ft lbs.
<b>Blade carrier bent</b>	Hitting solid objects.	Replace damaged blades. Be alert, avoid solid objects.
<b>Excessive skid shoe wear</b>	Cutting height not level.	Adjust deck height.
	Soil abrasive.	Raise cutting height.
	Cutting too low.	Raise cutting height.
<b>Excessive vibration</b>	Locked blades.	Inspect and unlock blades.
	Blades have unequal weight.	Replace blades as a PAIR.
	Driveline is bent.	Straighten or replace Driveline.
	Blade carrier bent.	Replace/straighten blade carrier.
	power take-off cross not centered with yoke.	Disassemble and inspect for incorrectly located needles or damaged bearing cap.
<b>Hydraulic cylinder rod moves slow or jerky</b>	Air in oil.	Purge cylinder and hydraulic lines of air.
<b>Hydraulic cylinder fittings leak oil</b>	Loose fittings.	Tighten fittings.
	Cracked fittings from over-tightening.	Replace fittings, don't over-tighten.
	Cylinder port cracked.	Repair or replace cylinder.
<b>Hydraulic cylinder leaks oil around the rod</b>	Seals are damaged or worn.	Replace seals.
	Cylinder rod is damaged.	Clean or replace cylinder rod.
	Cylinder rod is bent.	Determine cause of overload on cylinder rod. Replace cylinder rod.
<b>Cylinder rod is bent</b>	Operator abuse.	Travel slower. Don't hit objects with the deck while moving.
	Interference with cylinder operation.	Don't extend or retract cylinders with obstructions in the way. Move cutter or clean obstructions out of the way.
<b>Hydraulic cylinders will not extend and/or retract</b>	Orifice elbow on rod end is plugged.	Clean orifice fitting.
<b>Hydraulic cylinders will not retract</b>	Cylinder rod is bent.	Replace cylinder.



Torque Values Chart for Common Bolt Sizes													
Bolt Size (inches)	Bolt Head Identification						Bolt Size (Metric)	Bolt Head Identification					
	Grade 2		Grade 5		Grade 8			Class 5.8		Class 8.8		Class 10.9	
in-tpi <sup>1</sup>	N · m <sup>2</sup>	ft-lb <sup>3</sup>	N · m	ft-lb	N · m	ft-lb	mm x pitch <sup>4</sup>	N · m	ft-lb	N · m	ft-lb	N · m	ft-lb
1/4" - 20	7.4	5.6	11	8	16	12	M 5 X 0.8	4	3	6	5	9	7
1/4" - 28	8.5	6	13	10	18	14	M 6 X 1	7	5	11	8	15	11
5/16" - 18	15	11	24	17	33	25	M 8 X 1.25	17	12	26	19	36	27
5/16" - 24	17	13	26	19	37	27	M 8 X 1	18	13	28	21	39	29
3/8" - 16	27	20	42	31	59	44	M10 X 1.5	33	24	52	39	72	53
3/8" - 24	31	22	47	35	67	49	M10 X 0.75	39	29	61	45	85	62
7/16" - 14	43	32	67	49	95	70	M12 X 1.75	58	42	91	67	125	93
7/16" - 20	49	36	75	55	105	78	M12 X 1.5	60	44	95	70	130	97
1/2" - 13	66	49	105	76	145	105	M12 X 1	90	66	105	77	145	105
1/2" - 20	75	55	115	85	165	120	M14 X 2	92	68	145	105	200	150
9/16" - 12	95	70	150	110	210	155	M14 X 1.5	99	73	155	115	215	160
9/16" - 18	105	79	165	120	235	170	M16 X 2	145	105	225	165	315	230
5/8" - 11	130	97	205	150	285	210	M16 X 1.5	155	115	240	180	335	245
5/8" - 18	150	110	230	170	325	240	M18 X 2.5	195	145	310	230	405	300
3/4" - 10	235	170	360	265	510	375	M18 X 1.5	220	165	350	260	485	355
3/4" - 16	260	190	405	295	570	420	M20 X 2.5	280	205	440	325	610	450
7/8" - 9	225	165	585	430	820	605	M20 X 1.5	310	230	650	480	900	665
7/8" - 14	250	185	640	475	905	670	M24 X 3	480	355	760	560	1050	780
1" - 8	340	250	875	645	1230	910	M24 X 2	525	390	830	610	1150	845
1" - 12	370	275	955	705	1350	995	M30 X 3.5	960	705	1510	1120	2100	1550
1-1/8" - 7	480	355	1080	795	1750	1290	M30 X 2	1060	785	1680	1240	2320	1710
1-1/8" - 12	540	395	1210	890	1960	1440	M36 X 3.5	1730	1270	2650	1950	3660	2700
1-1/4" - 7	680	500	1520	1120	2460	1820	M36 X 2	1880	1380	2960	2190	4100	3220
1-1/4" - 12	750	555	1680	1240	2730	2010	<sup>1</sup> in-tpi = nominal thread diameter in inches-threads per inch <sup>2</sup> N · m = newton-meters <sup>3</sup> ft-lb= foot pounds <sup>4</sup> mm x pitch = nominal thread diameter in millimeters x thread pitch						
1-3/8" - 6	890	655	1990	1470	3230	2380							
1-3/8" - 12	1010	745	2270	1670	3680	2710							
1-1/2" - 6	1180	870	2640	1950	4290	3160							
1-1/2" - 12	1330	980	2970	2190	4820	3560							
Torque tolerance + 0%, -15% of torquing values. Unless otherwise specified use torque values listed above.													
Additional Torque Values													
Blade Bolt Locknut							450 ft-lbs.						
Blade Carrier Hub Nut							450 ft-lbs.						

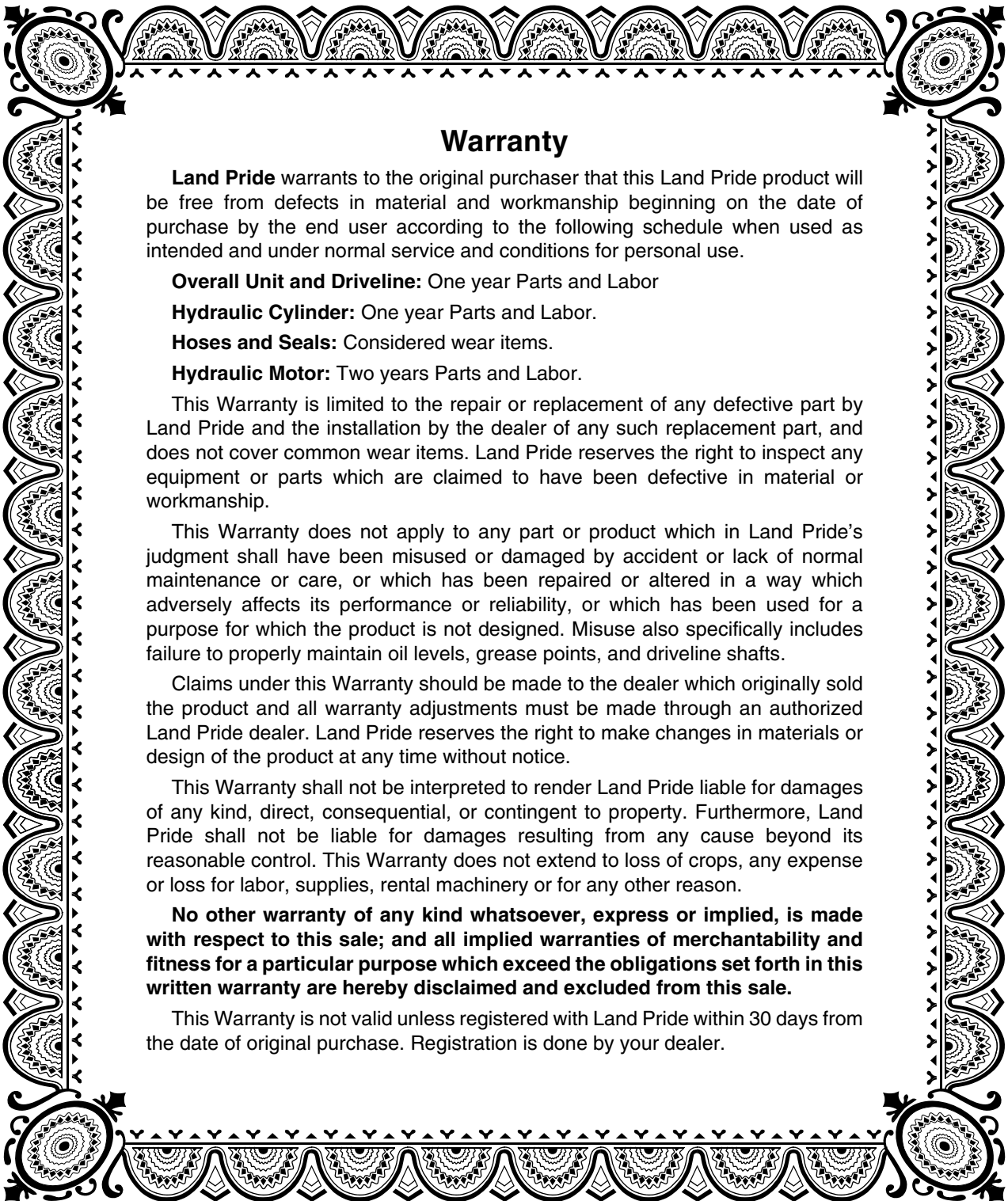

## Warranty

**Land Pride** warrants to the original purchaser that this Land Pride product will be free from defects in material and workmanship beginning on the date of purchase by the end user according to the following schedule when used as intended and under normal service and conditions for personal use.

**Overall Unit and Driveline:** One year Parts and Labor

**Hydraulic Cylinder:** One year Parts and Labor.

**Hoses and Seals:** Considered wear items.

**Hydraulic Motor:** Two years Parts and Labor.

This Warranty is limited to the repair or replacement of any defective part by Land Pride and the installation by the dealer of any such replacement part, and does not cover common wear items. Land Pride reserves the right to inspect any equipment or parts which are claimed to have been defective in material or workmanship.

This Warranty does not apply to any part or product which in Land Pride's judgment shall have been misused or damaged by accident or lack of normal maintenance or care, or which has been repaired or altered in a way which adversely affects its performance or reliability, or which has been used for a purpose for which the product is not designed. Misuse also specifically includes failure to properly maintain oil levels, grease points, and driveline shafts.

Claims under this Warranty should be made to the dealer which originally sold the product and all warranty adjustments must be made through an authorized Land Pride dealer. Land Pride reserves the right to make changes in materials or design of the product at any time without notice.

This Warranty shall not be interpreted to render Land Pride liable for damages of any kind, direct, consequential, or contingent to property. Furthermore, Land Pride shall not be liable for damages resulting from any cause beyond its reasonable control. This Warranty does not extend to loss of crops, any expense or loss for labor, supplies, rental machinery or for any other reason.

**No other warranty of any kind whatsoever, express or implied, is made with respect to this sale; and all implied warranties of merchantability and fitness for a particular purpose which exceed the obligations set forth in this written warranty are hereby disclaimed and excluded from this sale.**

This Warranty is not valid unless registered with Land Pride within 30 days from the date of original purchase. Registration is done by your dealer.

**IMPORTANT:** The Online Warranty Registration should be completed by the dealer at the time of purchase. This information is necessary to provide you with quality customer service.

**Model Number** \_\_\_\_\_

**Serial Number** \_\_\_\_\_



Corporate Office: P.O. Box 5060  
Salina, Kansas 67402-5060 USA  
[www.landpride.com](http://www.landpride.com)

---