

RCF(M)3696 & RCF(M)3610 Models

Specifications & Capacities		
Model Numbers	RCF3696 (540 rpm) RCFM3696 (1000 rpm)	RCF3610 (540 rpm) RCFM3610 (1000 rpm)
Machine weight with front & rear rubber guards. Includes hydraulic cylinder & 21" wheels with semi-mount and pull type units	3-Point mount = 1,750 lbs (793.8 kg) Semi-mount = 1,915 lbs (868.6 kg) Pull-type = 2,090 lbs (948.0 kg)	3-Point mount = 2,230 lbs (1011.5 kg) Semi-mount = 2,270 lbs (1029.7 kg) Pull-type = 2,430 lbs (1102.2 kg)
Hitch	3-Point & semi-mount Category 1 & 2	3-Point & semi-mount Category 2 & 3
Pull type tongue weight	933 lbs (423.2 kg)	1087 lbs (493.1 kg)
Park jack	Parking jack attaches to the tongue of the pull type cutter	
Cutting width	8' - 0" (2.44 m)	10' - 0" (3.05 m)
Overall width	8' - 7" (2.62 m)	10' - 6 1/2" (3.21 m)
Overall length	3-point mounted semi-mounted pull-type	
	8' - 10" (2.69 m) 9' - 5" (2.87 m) 12' - 5" (3.78 m)	10' - 2" (3.10 m) 10' - 2" (3.10 m) 13' - 1" (3.99 m)
Deck height	13" (33.0 cm)	
Cutting height	2" - 12" (5.1 cm - 30.5 cm)	
Cutting capacity	3" (7.6 cm)	
Tractor Hp rating	Lift-type - 50 - 130 (37.3 - 96.9 kw) Semi mount - 40 - 130 (29.8 - 96.9 kw) Pull-type - 35 - 130 (26.1 - 96.9 kw)	Lift-type - 60 - 130 (44.7 - 96.9 kw) Pull/semi - 50 - 130 (37.3 - 96.9 kw)
Gearbox horsepower rating	T-Box - 210 hp (156.6 kw), outboard 205 hp (152.9 kw)	
Gearbox	540 rpm or 1000 rpm driven gearbox. Cast iron housing, beveled gears	
Gearbox input / output shaft size	Input shaft = 1 3/4" (4.4 cm) - 20 spline Output shaft = 2 3/8" (6.0 cm) Dia.	
Gearbox lubrication	80-90w EP gear lube	
Gearbox oil capacity	end boxes T-box	Omni = 5.5 pints (2.60 L) or Comer = 10 pints (4.73 L) Comer = 4.5 pints (2.13 L)
Deck material thickness	10 gauge (3.4 mm)	
Deck side skirt thickness	1/4" (6 mm)	
Skids	Replaceable	
Stump jumper	2 ea. - 3/16" (5 mm) Round pan	
Blades (4)	1/2" x 4" (1.3 cm x 10.2 cm) Heat treated Free-swinging suction blades	
Blade bolts	Keyed with harden flat washer and locknut	
Blade tip speed	540 rpm 17,100 fpm (86.9 mps) 1000 rpm 17,400 fpm (88.4 mps)	540 rpm 17,100 fpm (86.9 mps) 1000 rpm 17,400 fpm (88.4 mps)
Driveline	3-point & semi-mount pull type	ASAE Cat 4 ASE Cat. 4 equal angle shaft or constant velocity u-joint
Driveline protection	540 rpm - 4 plate slip clutch, Rubber flex coupler to wing boxes 1000 rpm - 2 plate slip clutch, Rubber flex coupler to wing boxes	
Tailwheel options		
3-point without rear axle: 2 tires	4" x 8" x 15 1/4" Caster laminated	
3-point with rear axle: 2 tires	4" x 8" x 15 1/4" Caster laminated or 6" x 9" x 21" caster laminated	
semi-mount: 2 tires	4" x 8" x 15 1/4" Caster laminated or 6" x 9" x 21" caster laminated	
pull-type w/single spindle: 2 tires	6" x 9" x 21" Laminated or 24" x 7.7" recap foam filled aircraft or 29" x 16 ply aircraft	
pull-type w/dual spindles: 4 tires	6" x 9" x 21" Laminated or 24" x 7.7" recap foam filled aircraft or 29" x 16 ply aircraft	
Wheel bearings	Tapered roller bearing in cast iron hub	
Shock absorption	Spring shock absorber on axle of semi-mount & pull type	
Front guard	Optional: Rubber deflector, single chain guard, or double chain guard	
Rear guard	Optional: Rubber deflector, single chain guard, or double chain guard	

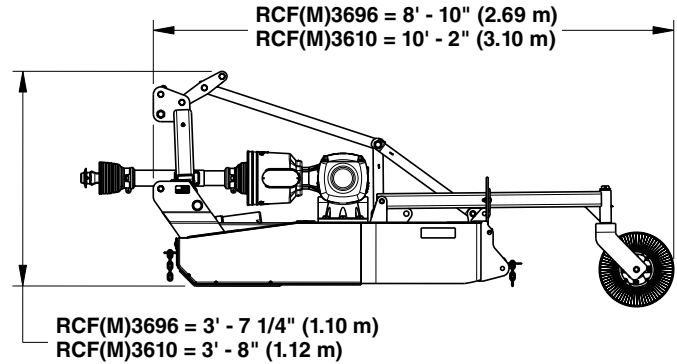
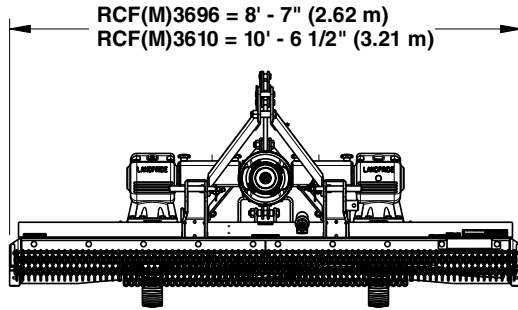

33967

3-Point Mounted Rotary Cutter (RC3696 Shown)

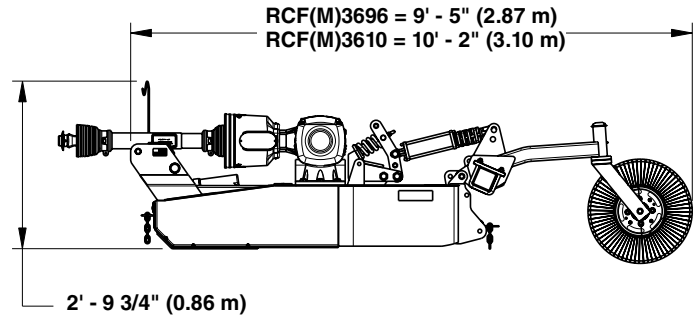
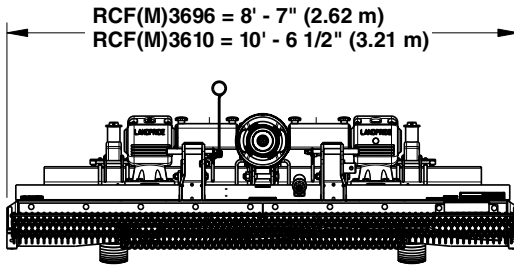

33968

Semi-Mounted Rotary Cutter (RC3696 Shown)

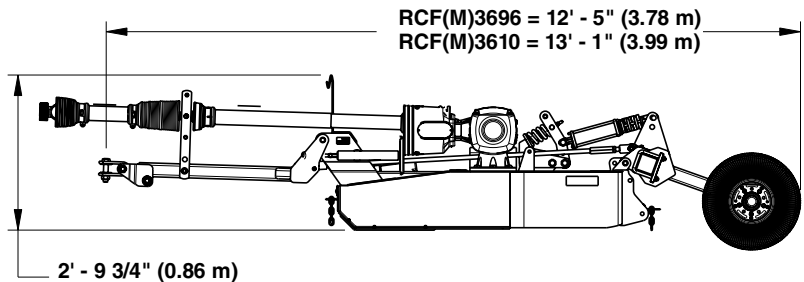
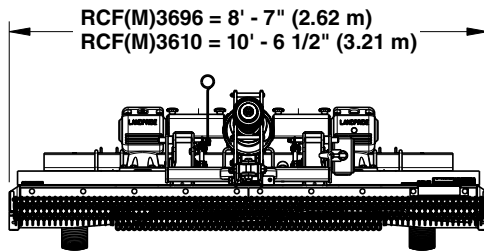

33969

Pull-Type Rotary Cutter (RC3696 Shown)