

# Rotary Cutters

RCF3684

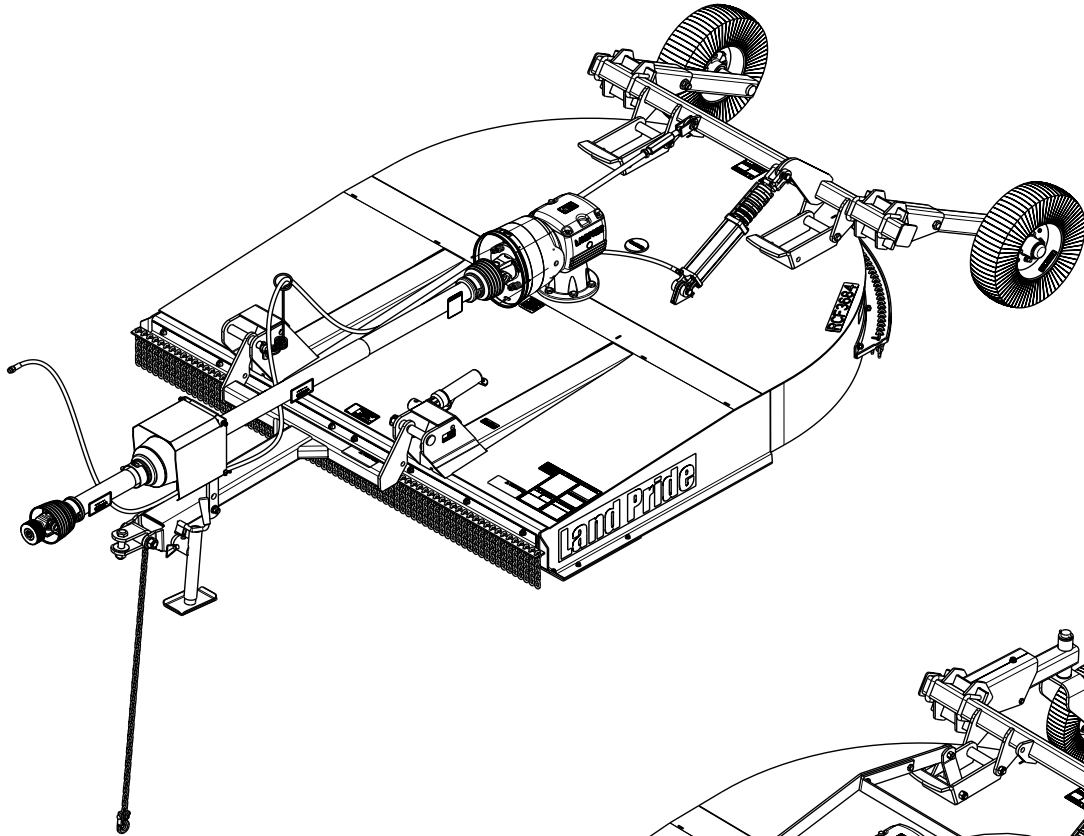

30867

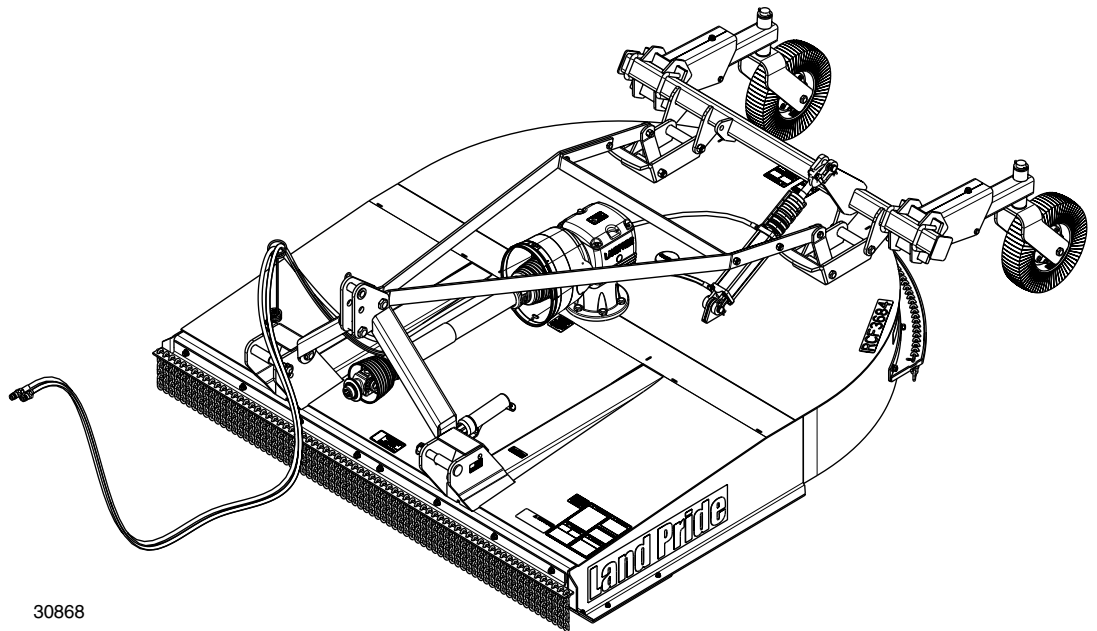

30868

## 326-412M Operator's Manual



Read the Operator's Manual entirely. When you see this symbol, the subsequent instructions and warnings are serious - follow without exception. Your life and the lives of others depend on it!

*Cover photo may show optional equipment not supplied with standard unit.*

*For an Operator's Manual and Decal Kit in French Language, please see your Land Pride dealer.*



## Machine Identification

Record your machine details in the log below. If you replace this manual, be sure to transfer this information to the new manual.

If you, or the dealer, have added Options not originally ordered with the machine, or removed Options that were originally ordered, the weights and measurements are no longer accurate for your machine. Update the record by adding the machine weight and measurements provided in the Specifications & Capacities Section of this manual with the Option(s) weight and measurements.

<b>Model Number</b>	
<b>Serial Number</b>	
<b>Machine Height</b>	
<b>Machine Length</b>	
<b>Machine Width</b>	
<b>Machine Weight</b>	
<b>Delivery Date</b>	
<b>First Operation</b>	
<b>Accessories</b>	<hr/> <hr/> <hr/>

## Dealer Contact Information

**Name:** \_\_\_\_\_

**Street:** \_\_\_\_\_

**City/State:** \_\_\_\_\_

**Telephone:** \_\_\_\_\_

**Email:** \_\_\_\_\_

 <b>California Proposition 65</b> <b>WARNING:</b> Cancer and reproductive harm - <a href="http://www.P65Warnings.ca.gov">www.P65Warnings.ca.gov</a>
---

<b>Important Safety Information</b> . . . . .	<b>1</b>	<b>Section 2: Optional Equipment Set-Up</b> . . . . .	<b>24</b>
Safety at All Times . . . . .	1	Front and Rear Guard Installations . . . . .	24
Look For The Safety Alert Symbol . . . . .	1	Front Rubber Guard . . . . .	24
Safety Labels . . . . .	6	Front Chain Guard (Single & Double) . . . . .	24
<b>Introduction</b> . . . . .	<b>10</b>	Rear Chain Guard (Single & Double) . . . . .	25
Application . . . . .	10	Rear Metal Deflector . . . . .	25
Using This Manual . . . . .	10	Shredder/Fixed Blades & Baffle Kits . . . . .	26
Owner Assistance . . . . .	10	Assembly Instructions . . . . .	26
<b>Section 1: Assembly &amp; Set-Up</b> . . . . .	<b>11</b>	Removal of Existing Blade Carriers . . . . .	26
Tractor Requirements . . . . .	11	Shredder Assembly . . . . .	27
Torque Requirements . . . . .	11	Check Free Vertical Movement of Blades . . . . .	27
Uncrating Instructions . . . . .	11	Front Fixed Blade Assembly . . . . .	28
Gearbox Vented Dipstick . . . . .	11	Left Side Fixed Blade Assembly . . . . .	28
3-Point Cutter Assembly & Set-up . . . . .	12	<b>Section 3: Adjustments</b> . . . . .	<b>29</b>
Spring Hose Loop . . . . .	12	Level & Set Deck Height (3-point) . . . . .	29
Tailwheel Assembly (3-Point) . . . . .	12	Level Left to Right (3-Point) . . . . .	29
Tailwheel Lift Options (3-Point) . . . . .	12	Cutting Height (3-Point) . . . . .	29
Hitch Assembly (3-Point) . . . . .	12	Tailwheel Height (3-Point) . . . . .	30
Hitch Arrangements (3-Point) . . . . .	13	Ratchet Jack . . . . .	30
Category II Hitch (3-Point) . . . . .	13	Hydraulic Cylinder . . . . .	30
Category III Hitch (3-Point) . . . . .	13	Center 3-Point Link (3-Point) . . . . .	30
Category III Quick Hitch (3-Point) . . . . .	13	Level & Set Deck Height (Pull-Type) . . . . .	31
Category III Quick Hitch (3-Point) . . . . .	13	Level Front To Back (Pull-Type) . . . . .	31
Driveline Installation (3-Point) . . . . .	14	Cutting Height (Pull-Type) . . . . .	31
Hitch Hook-up (3-Point) . . . . .	14	Ratchet Jack . . . . .	32
Driveline Hook-up (3-Point) . . . . .	15	Hydraulic Cylinder . . . . .	32
Hydraulic Hook-up (3-Point) . . . . .	16	<b>Section 4: Operating Instructions</b> . . . . .	<b>33</b>
Check Driveline Collapsible Length . . . . .	16	Operating Checklist . . . . .	33
Check Driveline Maximum Length . . . . .	17	Safety Information . . . . .	33
Check Driveline Interference . . . . .	18	Inspect Tractor & Cutter . . . . .	34
Pull-Type Cutter Assembly & Set-up . . . . .	19	Tractor Shutdown Procedure . . . . .	35
Axle Assembly . . . . .	19	Transporting . . . . .	35
Tailwheel Lift Options (Pull-Type) . . . . .	19	Turning Angles for Pull-Type Cutters . . . . .	35
Spring Hose Loop (Pull-Type) . . . . .	19	Crossing Steep Ditches & Banks . . . . .	35
Hitch Assembly (Pull-Type) . . . . .	20	Blade Engagement & Disengagement . . . . .	36
Jack-shaft Driveline Assembly (Pull-Type) . . . . .	21	Blade Engagement . . . . .	36
Front Driveline Assembly (Pull-Type) . . . . .	21	Blade Disengagement . . . . .	36
Hitch Hook-up (Pull-Type) . . . . .	22	Field Operation . . . . .	36
Hydraulic Hook-up (Pull-Type) . . . . .	23	Unhook 3-Point Hitch . . . . .	37
Purge Hydraulic System (Pull-Type) . . . . .	23	Unhook Pull-Type Hitch . . . . .	38
		General Operating Instructions . . . . .	39

Continue Table of Contents on next page



© Copyright 2020 All rights Reserved

Land Pride provides this publication “as is” without warranty of any kind, either expressed or implied. While every precaution has been taken in the preparation of this manual, Land Pride assumes no responsibility for errors or omissions. Neither is any liability assumed for damages resulting from the use of the information contained herein. Land Pride reserves the right to revise and improve its products as it sees fit. This publication describes the state of this product at the time of its publication, and may not reflect the product in the future.

Land Pride is a registered trademark.

All other brands and product names are trademarks or registered trademarks of their respective holders.

Printed in the United States of America.

**Section 5: Maintenance & Lubrication . . . . . 40**  
 Maintenance . . . . . 40  
 Skid Shoes . . . . . 40  
 Cutter Blade Maintenance . . . . . 41  
 Driveline Slip-Clutch . . . . . 42  
 Clutch Run-In . . . . . 42  
 Clutch Assembly and Disassembly . . . . . 42  
     Disassembly . . . . . 42  
 3-Point Sandwich Mount . . . . . 43  
 Pull-Type Wheel Cushion . . . . . 43  
 Long-Term Storage . . . . . 44  
 Ordering Replacement Parts . . . . . 45  
 Lubrication Points . . . . . 46  
     Gauge Wheel Spindle Tube . . . . . 46  
     Gauge Wheel Hub . . . . . 47  
     Driveline U-joints . . . . . 47  
     Driveline Shield Bearings . . . . . 47  
     Driveline Profiles . . . . . 47  
     Gearbox . . . . . 47  
     Ratchet Jack (Optional) . . . . . 53  
**Section 6: Specifications & Capacities . . . . . 53**  
**Section 7: Features & Benefits . . . . . 53**  
**Section 8: Troubleshooting . . . . . 53**  
**Section 9: Torque Values Chart . . . . . 53**  
**Section 10: Warranty . . . . . 53**



**Parts Manual QR Locator**  
 The QR (Quick Reference) code on the cover and to the left will take you to the Parts Manual for this equipment. Download the appropriate App on your smart phone, open the App, point your phone on the QR code and take a picture.



**Dealer QR Locator**  
 The QR code on the left will link you to available dealers for Land Pride products. Refer to Parts Manual QR Locator on this page for detailed instructions.



These are common practices that may or may not be applicable to the products described in this manual.

### Safety at All Times

Careful operation is your best insurance against an accident.

All operators, no matter how much experience they may have, should carefully read this manual and other related manuals before operating the power machine and this implement.

- ▲ Thoroughly read and understand the "Safety Label" section, read all instructions noted on them.
- ▲ Do not operate the equipment while under the influence of drugs or alcohol as they impair the ability to safely and properly operate the equipment.
- ▲ The operator should be familiar with all functions of the tractor and attached implement, and be able to handle emergencies quickly.
- ▲ Make sure all guards and shields are in place and secured before operating implement.
- ▲ Keep all bystanders away from equipment and work area.
- ▲ Start tractor from the driver's seat with hydraulic controls in neutral.
- ▲ Operate tractor and controls from the driver's seat only.
- ▲ Never dismount from a moving tractor or leave tractor unattended with engine running.
- ▲ Do not allow anyone to stand between tractor and implement while backing up to implement.
- ▲ Keep hands, feet, and clothing away from power-driven parts.
- ▲ While transporting and operating equipment, watch out for objects overhead and along side such as fences, trees, buildings, wires, etc.
- ▲ Do not turn tractor so tight as to cause hitched implement to ride up on the tractor's rear wheel.
- ▲ Store implement in an area where children normally do not play. When needed, secure implement against falling with support blocks.



### Look For The Safety Alert Symbol

The SAFETY ALERT SYMBOL indicates there is a potential hazard to personal safety involved and extra safety precaution must be taken. When you see this symbol, be alert and carefully read the message that follows it. In addition to design and configuration of equipment, hazard control, and accident prevention are dependent upon the awareness, concern, prudence, and proper training of personnel involved in the operation, transport, maintenance, and storage of equipment.

#### Be Aware of Signal Words

A signal word designates a degree or level of hazard seriousness. The signal words are:

##### DANGER

Indicates a hazardous situation that, if not avoided, will result in death or serious injury.

##### WARNING

Indicates a hazardous situation that, if not avoided, could result in death or serious injury.

##### CAUTION

Indicates a hazardous situation that, if not avoided, may result in minor or moderate injury.

### Safety Precautions for Children

Tragedy can occur if the operator is not alert to the presence of children, Children generally are attracted to implements and their work.

- ▲ Never assume children will remain where you last saw them.
- ▲ Keep children out of the work area and under the watchful eye of a responsible adult.
- ▲ Be alert and shut the implement and tractor down if children enter the work area.
- ▲ Never carry children on the tractor or implement. There is not a safe place for them to ride. They may fall off and be run over or interfere with the control of the power machine.
- ▲ Never allow children to operate the power machine, even under adult supervision.
- ▲ Never allow children to play on the power machine or implement.
- ▲ Use extra caution when backing up. Before the tractor starts to move, look down and behind to make sure the area is clear.

### Tractor Shutdown & Storage

- ▲ If engaged, disengage power take-off.
- ▲ Park on solid, level ground and lower implement to ground or onto support blocks.
- ▲ Put tractor in park or set park brake, turn off engine, and remove switch key to prevent unauthorized starting.
- ▲ Relieve all hydraulic pressure to auxiliary hydraulic lines.
- ▲ Wait for all components to stop before leaving operator's seat.
- ▲ Use steps, grab-handles and skid-resistant surfaces when getting on and off the tractor.
- ▲ Detach and store implement in an area where children normally do not play. Secure implement using blocks and supports.

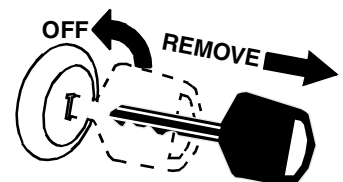

These are common practices that may or may not be applicable to the products described in this manual.

### Use A Safety Chain

- ▲ A safety chain will help control drawn machinery should it separate from the tractor drawbar.
- ▲ Use a chain with the strength rating equal to or greater than the gross weight of the towed implement.
- ▲ Attach the chain to the tractor drawbar support or other specified anchor location. Allow only enough slack in the chain to permit turning.
- ▲ Always hitch the implement to the machine towing it. Do not use the safety chain tow the implement.

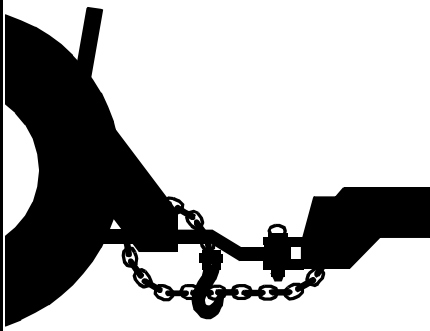

### Transport Safely

- ▲ Comply with federal, state, and local laws.
- ▲ Use towing vehicle and trailer of adequate size and capacity. Secure equipment towed on a trailer with tie downs and chains.
- ▲ Sudden braking can cause a towed trailer to swerve and upset. Reduce speed if towed trailer is not equipped with brakes.
- ▲ Avoid contact with any over head utility lines or electrically charged conductors.
- ▲ Always drive with load on end of loader arms low to the ground.
- ▲ Always drive straight up and down steep inclines with heavy end of a tractor with loader attachment on the "uphill" side.

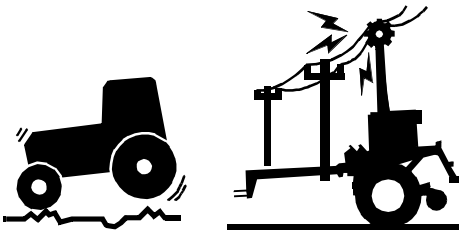

- ▲ Engage park brake when stopped on an incline.
- ▲ Maximum transport speed for an attached equipment is 20 mph. DO NOT EXCEED. Never travel at a speed which does not allow adequate control of steering and stopping. Some rough terrains require a slower speed.
- ▲ As a guideline, use the following maximum speed weight ratios for attached equipment:

**20 mph** when weight of attached equipment is less than or equal to the weight of machine towing the equipment.

**10 mph** when weight of attached equipment exceeds weight of machine towing equipment but not more than double the weight.

- ▲ **IMPORTANT:** Do not tow a load that is more than double the weight of the vehicle towing the load.



### Tire Safety

- ▲ Tire changing can be dangerous and must be performed by trained personnel using the correct tools and equipment.
- ▲ Always properly match the wheel size to the properly sized tire.
- ▲ Always maintain correct tire pressure. Do not inflate tires above recommended pressures shown in the Operator's Manual.
- ▲ When inflating tires, use a clip-on chuck and extension hose long enough to allow you to stand to one side and NOT in front of or over the tire assembly. Use a safety cage if available.
- ▲ Securely support the implement when changing a wheel.
- ▲ When removing and installing wheels, use wheel handling equipment adequate for the weight involved.
- ▲ Make sure wheel bolts have been tightened to the specified torque.



### Practice Safe Maintenance

- ▲ Understand procedure before doing work. Refer to the Operator's Manual for additional information.
- ▲ Work on a level surface in a clean dry area that is well-lit.
- ▲ Lower implement to the ground and follow all shutdown procedures before leaving the operator's seat to perform maintenance.
- ▲ Do not work under any hydraulically supported equipment. It can settle, suddenly leak down, or be lowered accidentally. If it is necessary to work under the equipment, securely support it with stands or suitable blocking beforehand.
- ▲ Use properly grounded electrical outlets and tools.
- ▲ Use correct tools and equipment for the job that are in good condition.
- ▲ Allow equipment to cool before working on it.

- ▲ Disconnect battery ground cable (-) before servicing or adjusting electrical systems or before welding on implement.
- ▲ Inspect all parts. Make certain parts are in good condition & installed properly.
- ▲ Replace parts on this implement with genuine Land Pride parts only. Do not alter this implement in a way which will adversely affect its performance.
- ▲ Do not grease or oil implement while it is in operation.
- ▲ Remove buildup of grease, oil, or debris.
- ▲ Always make sure any material and waste products from the repair and maintenance of the implement are properly collected and disposed.
- ▲ Remove all tools and unused parts from equipment before operation.
- ▲ Do not weld or torch on galvanized metal as it will release toxic fumes.



These are common practices that may or may not be applicable to the products described in this manual.

### Prepare for Emergencies

- ▲ Be prepared if a fire starts.
- ▲ Keep a first aid kit and fire extinguisher handy.
- ▲ Keep emergency numbers for doctor, ambulance, hospital, and fire department near phone.

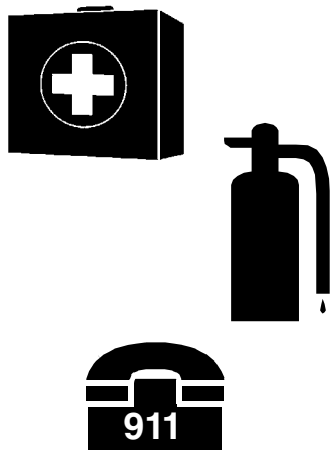

### Wear Protective Equipment

- ▲ Wear protective clothing and equipment appropriate for the job such as safety shoes, safety glasses, hard hat, and ear plugs.
- ▲ Clothing should fit snug without fringes and pull strings to avoid entanglement with moving parts.
- ▲ Prolonged exposure to loud noise can cause hearing impairment or hearing loss. Wear suitable hearing protection such as earmuffs or earplugs.
- ▲ Operating equipment safely requires the operator's full attention. Avoid wearing headphones while operating equipment.



### Avoid High Pressure Fluids

- ▲ Escaping fluid under pressure can penetrate the skin causing serious injury.
- ▲ Relieve all residual pressure before disconnecting hydraulic lines or performing work on the hydraulic system.
- ▲ Make sure all hydraulic fluid connections are properly tightened/torqued and all hydraulic hoses and lines are in good condition before applying pressure to the system.
- ▲ Use a piece of paper or cardboard, NOT BODY PARTS, to check for suspected leaks.
- ▲ Wear protective gloves and safety glasses or goggles when working with hydraulic systems.
- ▲ **DO NOT DELAY.** If an accident occurs, see a doctor familiar with this type of injury immediately. Any fluid injected into the skin or eyes must be treated within a few hours or gangrene may result.



### Use Safety Lights and Devices

- ▲ Slow moving tractors, and self-propelled equipment can create a hazard when driven on public roads. They are difficult to see, especially at night. Use the Slow Moving Vehicle (SMV) sign when on public roads.
- ▲ Flashing warning lights and turn signals are recommended whenever driving on public roads.

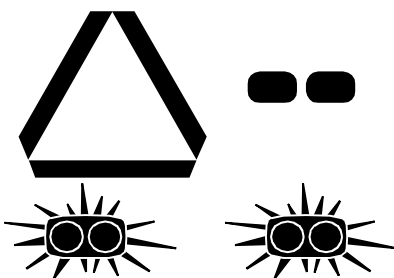

### Use Seat Belt and ROPS

- ▲ Land Pride recommends the use of a CAB or roll-over-protective-structures (ROPS) and seat belt in almost all power machines. Combination of a CAB or ROPS and seat belt will reduce the risk of serious injury or death if the power machine should be upset.
- ▲ If ROPS is in the locked-up position, fasten seat belt snugly and securely to help protect against serious injury or death from falling and machine overturn.

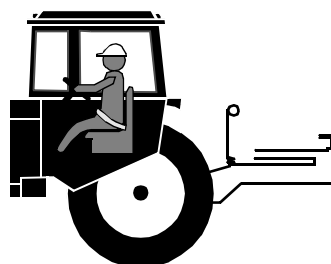

### Keep Riders Off Machinery

- ▲ Never carry riders or use tractor to lift or transport individuals.
- ▲ There is not a safe place for a person to ride.
- ▲ Riders obstruct operator's view and interfere with the control of the power machine.
- ▲ Riders can be struck by objects or thrown from the equipment.

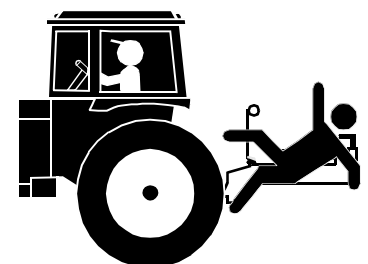

These are common practices that may or may not be applicable to the products described in this manual.

### Avoid crystalline Silica (quartz) Dust

Because crystalline silica is a basic component of sand and granite, many activities at construction sites produce dust containing crystalline silica. Trenching, sawing, and boring of material containing crystalline silica can produce dust containing crystalline silica particles. This dust can cause serious injury to the lungs (silicosis).

There are guidelines which should be followed if crystalline silica (quartz) is present in the dust.



- ▲ Be aware of and follow OSHA (or other local, State, or Federal) guidelines for exposure to airborne crystalline silica.
- ▲ Know the work operations where exposure to crystalline silica may occur.
- ▲ Participate in air monitoring or training programs offered by the employer.
- ▲ Be aware of and use optional equipment controls such as water sprays, local exhaust ventilation, and enclosed cabs with positive pressure air conditioning if the machine has such equipment. Otherwise respirators shall be worn.
- ▲ Where respirators are required, wear a respirator approved for protection against crystalline silica containing dust. Do not alter respirator in any way. Workers who use tight-fitting respirators can not have beards/mustaches which interfere with the respirator seal to the face.
- ▲ If possible, change into disposable or washable work clothes at the work site; shower and change into clean clothing before leaving the work site.
- ▲ Do not eat, drink, use tobacco products, or apply cosmetics in areas where there is dust containing crystalline silica.
- ▲ Store food, drink, and personal belongings away from the work area.
- ▲ Wash hands and face before eating, drinking, smoking, or applying cosmetics after leaving the exposure area.

### Handle Chemicals Properly

- ▲ Protective clothing should be worn.
- ▲ Handle all chemicals with care.
- ▲ Follow instructions on container label.
- ▲ Agricultural chemicals can be dangerous. Improper use can seriously injure persons, animals, plants, soil, and property.
- ▲ Inhaling smoke from any type of chemical fire is a serious health hazard.
- ▲ Store or dispose of unused chemicals as specified by the chemical manufacturer.



### Dig Safe - Avoid Underground Utilities

- ▲ **USA: Call 811**  
**CAN: [digsafecanada.ca](http://digsafecanada.ca)**  
Always contact your local utility companies (electrical, telephone, gas, water, sewer, and others) before digging so that they may mark the location of any underground services in the area.
- ▲ Be sure to ask how close you can work to the marks they positioned.



This page left blank intentionally.

## Important Safety Information

### Safety Labels

Your Rotary Cutter comes equipped with all safety labels in place. They were designed to help you safely operate your implement. Read and follow their directions.

1. Keep all safety labels clean and legible.
2. Refer to this section for proper label placement. Replace all damaged or missing labels. Order new labels from your nearest Land Pride dealer. To find your nearest dealer, visit our dealer locator at [www.landpride.com](http://www.landpride.com).
3. Some new equipment installed during repair requires safety labels to be affixed to the replaced component as

specified by Land Pride. When ordering new components make sure the correct safety labels are included in the request.

4. Refer to this section for proper label placement. To install new labels:
  - a. Clean surface area where label is to be placed.
  - b. Spray soapy water onto the cleaned area.
  - c. Peel backing from label and press label firmly onto the surface.
  - d. Squeeze out air bubbles with edge of a credit card or with a similar type of straight edge.

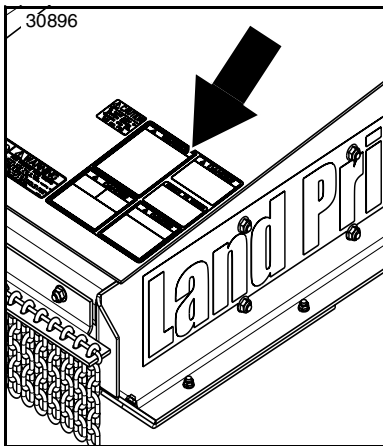

**844-190C**  
Safety Combo

<p><b>WARNING</b></p>	<p><b>DANGER</b></p>	<p><b>DANGER</b></p>
<p>To prevent serious injury or death:</p> <ul style="list-style-type: none"> <li>Do not operate or work on this machine without reading and understanding the Operator's Manual.</li> <li>Avoid unsafe operation or maintenance.</li> <li>Transport with clean reflectors, SMV, and lights as required by federal, state, and local laws.</li> <li>If manual is lost, contact your nearest dealer for a new manual.</li> </ul>	<p>ROTATING DRIVELINE CONTACT CAN CAUSE DEATH KEEP AWAY! DO NOT OPERATE WITHOUT:</p> <ul style="list-style-type: none"> <li>All driveline guards, tractor and equipment shields in place.</li> <li>Drivelines securely attached at both ends.</li> <li>Driveline guards that turn freely on driveline.</li> </ul> <p>DO NOT USE PTO ADAPTORS</p>	<p>THROWN OBJECT AND ROTATING BLADE HAZARD</p> <p>To prevent serious injury or death:</p> <ul style="list-style-type: none"> <li>Do not operate unless all guards are installed and in good condition.</li> <li>Inspect and clear debris from mowing area prior to mowing.</li> <li>Do not operate with bystanders in or around mowing area.</li> <li>Do not place hands or feet under deck when operating or when engine is running.</li> <li>Do not dismount until blades come to a complete stop.</li> </ul>
<p><b>WARNING</b></p>	<p><b>WARNING</b></p>	<p><b>WARNING</b></p>
<p>CRUSHING HAZARD</p> <p>Before performing maintenance on machine and to prevent serious injury or death:</p> <ul style="list-style-type: none"> <li>Read and understand operator's manual.</li> <li>Stop engine, set brake, and wait for all moving parts to stop before dismounting.</li> <li>Support cutter securely before working beneath.</li> </ul>	<p>RUN OVER HAZARD</p> <p>To prevent serious injury or death:</p> <ul style="list-style-type: none"> <li>Always use seat belt when operating.</li> <li>Never allow riders on tractor or machine.</li> </ul>	<p>ROLLOVER HAZARD</p> <p>To prevent serious injury or death:</p> <ul style="list-style-type: none"> <li>Always use seat belt when operating.</li> <li>Only operate on tractors equipped with a rollover protective structure (ROPS).</li> <li>If equipped with foldable ROPS, only operate in the unfolded and locked position.</li> <li>Use caution when mowing along inclines.</li> </ul>

⚠ WARNING: Cancer and reproductive harm · [www.P65Warnings.ca.gov](http://www.P65Warnings.ca.gov)

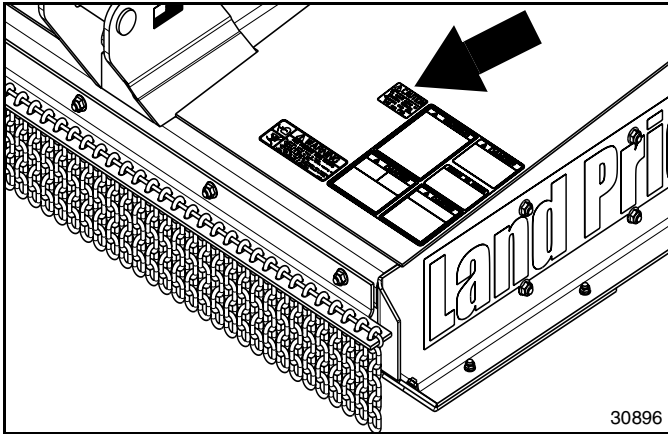

**818-130C**

Warning: 540 rpm

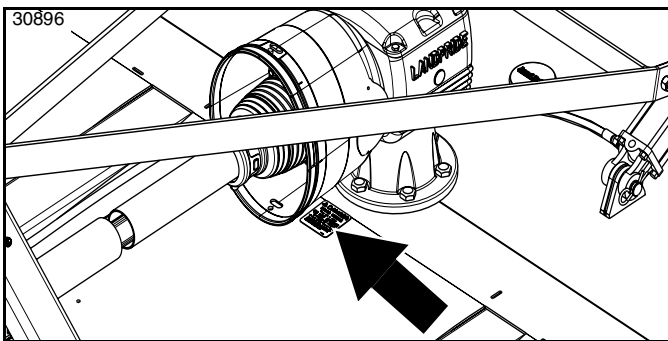

**818-543C**

Danger: Guard Missing (2 places)

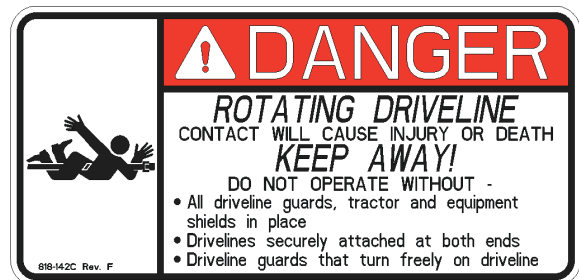
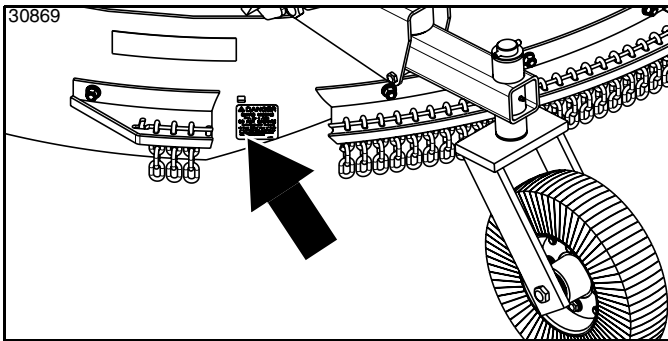

**818-142C**

Danger: Rotating Driveline

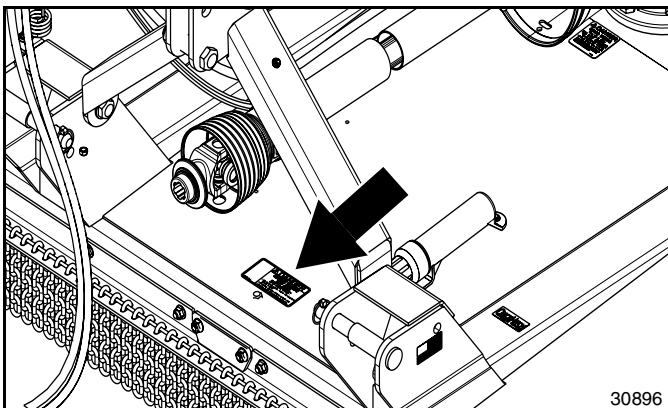

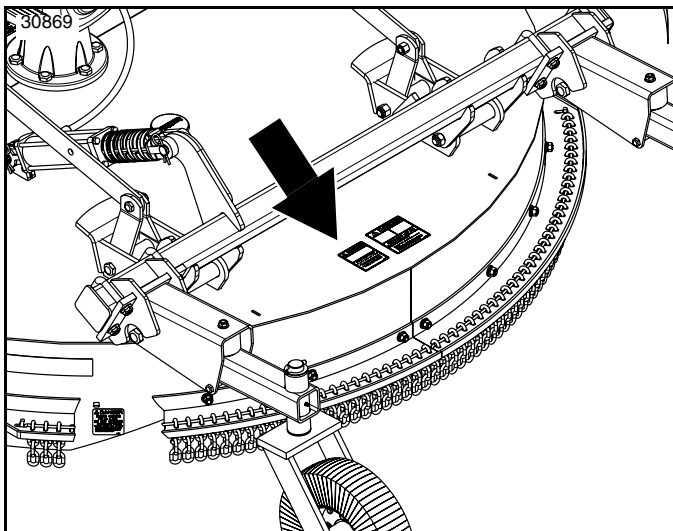

**818-556C**

Danger: Thrown Object

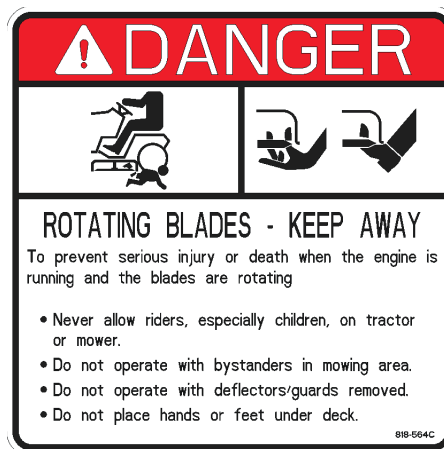
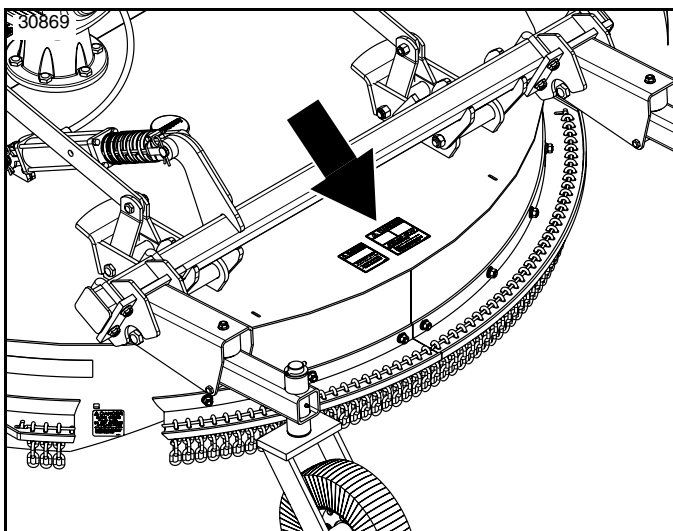

**818-564C**

Danger: Rotating Blades

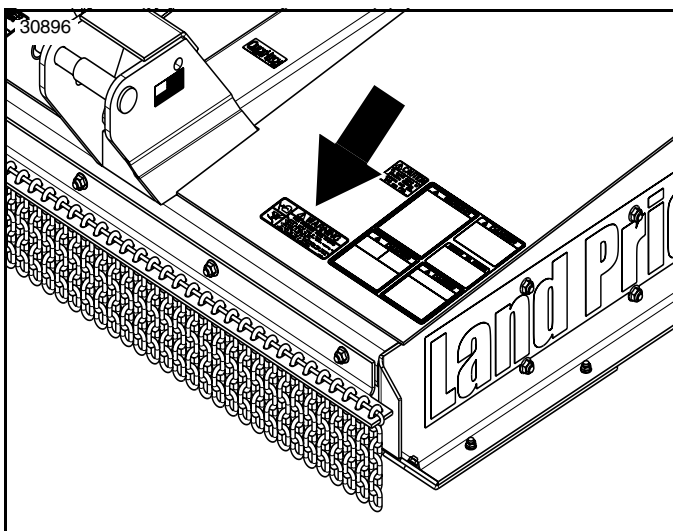

**838-094C**

Warning: High Pressure Fluid Hazard



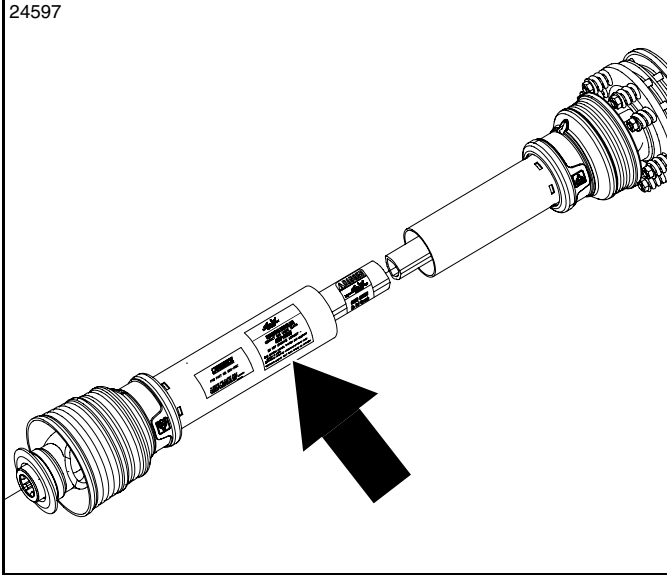

**818-552C**

Danger: Rotating Driveline

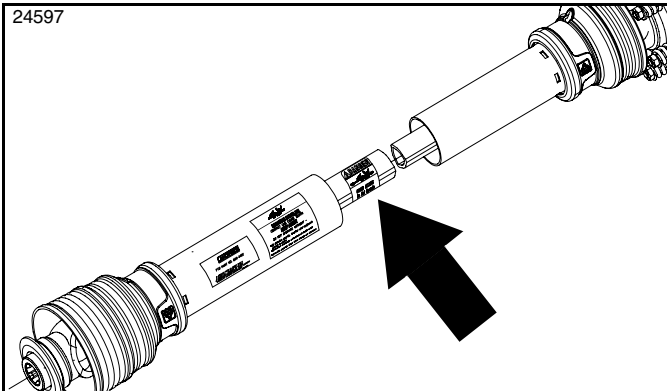

**818-540C**

Danger: Guard Missing

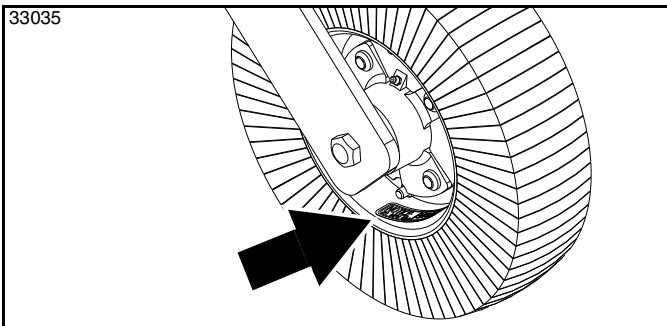

**818-681C**

Notice: 20 MPH Max.

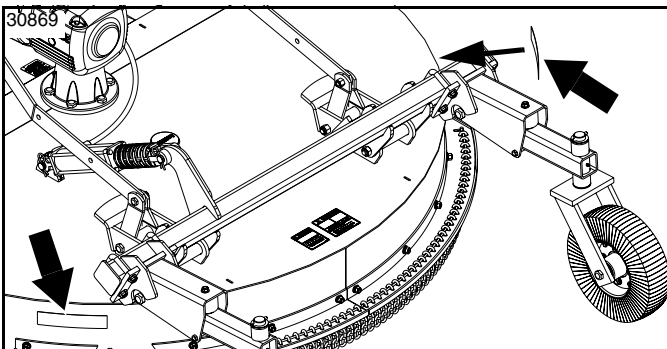

**838-614C**

2" x 9" Red Reflector (2 places)

## Introduction

Land Pride welcomes you to the growing family of new product owners. This Rotary Cutter has been designed with care and built by skilled workers using quality materials. Proper assembly, maintenance, and safe operating practices will help you get years of satisfactory use from this product.

## Application

The RCF3684 Rotary Cutters are designed and built by Land Pride to provide excellent cutting performance on gentle slopes, slightly contoured right-of-ways, pastures, set aside acres, row crop fields, and roadsides. Its +84" cutting width with category II & III three-point hitch is compatible with 70 to 190 hp tractors or pull type with 50 to 190 hp tractors at 540 rpm power take-off speed. The three-point hitch is also Quick Hitch adaptable. The driveline is protected with a 4 plate slip clutch.

The cutter can cut through grass, weeds, crops, brush, and small trees up to 4" in diameter and has a cutting height range of 2" to 12" with a cutting blade tip speed of 14,369 FPM. This unit comes with a standard 3/16" heavy-duty dish stump jumper and replaceable bolt-on skid shoes. Optional shields for the front are rubber deflector, single chain guard, or double chain guard. Optional shields available for the rear are either single or double chain guard.

See "**Specifications & Capacities**" on page 53 and "**Features & Benefits**" on page 53 for additional information and performance enhancing options.

## Using This Manual

- This Operator's Manual is designed to help familiarize the operator with safety, assembly, operation, adjustments, troubleshooting, and maintenance. Read this manual and follow the recommendations to help ensure safe and efficient operation.
- The information contained within this manual was current at the time of printing. Some parts may change slightly to assure you of the best performance.
- To order a new Operator's or Parts Manual, contact your authorized dealer. Manuals can also be downloaded, free-of-charge, from our website at [www.landpride.com](http://www.landpride.com)

## Terminology:

"Right" or "Left" as used in this manual is determined by facing the direction the machine will operate while in use unless otherwise stated.

## Definitions:

**IMPORTANT:** A special point of information related to the following topic. Land Pride's intention is this information must be read & noted before continuing.

**NOTE:** A special point of information that the operator should be aware of before continuing.

## Owner Assistance

The dealer should complete the Online Warranty Registration at the time of purchase. This information is necessary to provide you with quality customer service.

The parts on your Rotary Cutter have been specially designed by Land Pride and should only be replaced with genuine Land Pride parts. Contact a Land Pride dealer if customer service or repair parts are required. Your Land Pride dealer has trained personnel, repair parts, and equipment needed to service the implement.

## Serial Number

For quick reference and prompt service, record model and serial number on the inside cover page and again on the warranty page. Always provide model number and serial number when ordering parts and in all correspondences with your Land Pride dealer. For location of your serial number plate, see Figure 1.

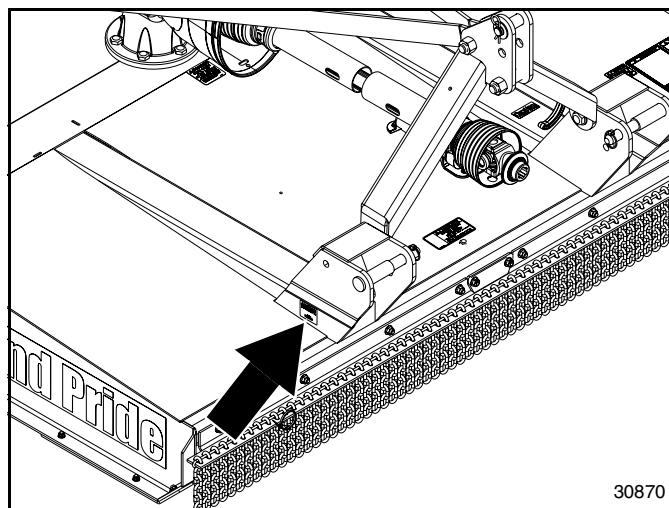

Figure 1

## Further Assistance

Your dealer wants you to be satisfied with your new Rotary Cutter. If for any reason you do not understand any part of this manual or are not satisfied with the service received, the following actions are suggested:

1. Discuss any problems you have with your implement with your dealership service personnel so they can address the problem.
2. If you are still not satisfied, seek out the owner or general manager of the dealership, explain the question/problem, and request assistance.
3. For further assistance write to:

**Land Pride Service Department**  
**1525 East North Street**  
 P.O. Box 5060  
 Salina, Ks. 67402-5060

E-mail address  
[lp servicedept@landpride.com](mailto:lp servicedept@landpride.com)

Section 1: Assembly & Set-Up

**Tractor Requirements**

Tractor horsepower and hitch category should be within the range noted below. Tractors outside the horsepower range must not be used.

Tractor Horsepower Rating	
3-Point Hitch	70 to 190 hp
Pull Type Hitch	50 to 190 hp
3-Point Hitch Category	Cat II & III
Power Take-Off Speed	.540 rpm
Hydraulic Outlets (With Hydraulic Option)	
3-Point Hitch	Duplex Outlet
Pull Type Hitch	Duplex Outlet
Tractor Weight	See Warning Below

**WARNING**

To avoid serious injury or death:

Lightweight tractors with rear attached implements may need weights added to the front to maintain steering control. Consult your tractor Operator's Manual to determine proper weight requirements and maximum weight limitations.

**Torque Requirements**

Refer to "Torque Values Chart" on page 52 to determine correct torque values for common bolts. See "Additional Torque Values" at bottom of chart for exceptions to standard torque values.

**Uncrating Instructions**

**WARNING**

To avoid serious injury or death:

- Always secure cutter with an overhead crane, fork lift, or other suitable lifting device before removing hardware bags, shipping components, bands, lag screws, or hitch pins. The cutter can suddenly fall.
- Components in second shipping crate for pull-type cutters can fall causing bodily injury when cutting shipping bands. Make certain components are properly supported before cutting shipping bands.

**NOTE:** A second shipping crate is included with the pull-type cutter. It should include hitch, bearing support assembly, front driveline, trailing wheel arms, and wheels.

**NOTE:** Assembly and set-up is easier and quicker if two men are available throughout set-up.

- Secure cutter with a hoist or other lifting device before removing shipping hardware.
- On the backside of the cutter, cut shipping straps and remove all components secured to the crate.
- On the backside of the cutter are a series of lag screws securing the cutter to the crate. Remove the lag screws.

- On the front side of the shipping crate, cut shipping straps and remove all components secured to the crate.
- 3-Point Only:** Remove screws securing rear brace bars to shipping crate.
- Remove bolts securing hitch pins to shipping crate.
- Using lifting device, remove tension on hitch pins, and pull hitch pins back until hitch assembly can be removed from shipping crate. Remove hitch assembly from shipping crate.
- Gently lift cutter up until hitch pins can be completely removed from shipping crate.
- Gently lift cutter off the shipping crate and lower unit onto the working area.
- Second Shipping Crate For Pull-Type Only:** Secure each component in the second shipping crate before cutting its shipping bands to make certain it will not fall and cause bodily injury.

**Gearbox Vented Dipstick**

Refer to Figure 1-1:

**IMPORTANT:** Gearboxes are shipped with solid plugs in them to prevent oil loss during shipping and handling. The solid plug on top of the gearbox must be replaced with a vented dipstick before operating the implement.

A vented dipstick is shipped loose and packaged with the Operator's Manual. Remove temporary solid plug from top of gearbox and replace with vented dipstick. See your nearest Land Pride dealer if dipstick is missing.

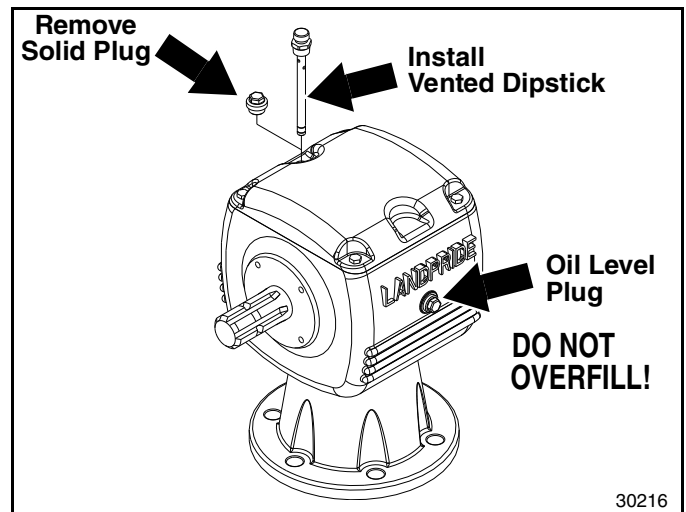

**Gearbox Vented Dipstick Installation**  
Figure 1-1

Section 1: Assembly & Set-Up

### 3-Point Cutter Assembly & Set-up

The following instructions are for assembling the 3-point cutter. See page 19 for “Pull-Type Cutter Assembly & Set-up” instructions.

#### Spring Hose Loop

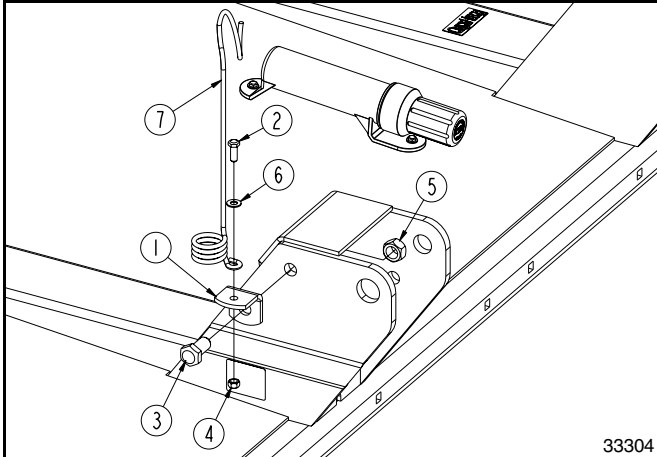

Spring Hose Loop Assembly  
Figure 1-2

Refer to Figure 1-2:

1. Attach hose holder bracket (#1) to right-hand clevis with 3/4"-10 1 1/2" GR5 cap screw (#3) and hex locknut (#5). Tighten locknut to the correct torque.
2. Attach spring hose loop (#7) to hose holder bracket with 3/8"-16 x 1" GR5 cap screw (#2), flat washer (#6), and locknut (#4). Tighten locknut to the correct torque.

#### Tailwheel Assembly (3-Point)

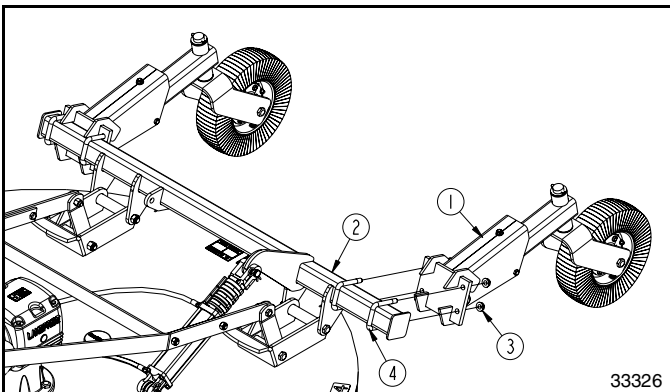

3-Point Tail Wheel Assembly  
Figure 1-3

Refer to Figure 1-3:

1. Screw quick disconnect coupling (supplied by customer) to end of hydraulic hoses.
2. Attach dual tailwheel arms (#1) to axle (#2) with 5/8"-11 x 3 1/32" x 4 1/4" GR5 U-bolts (#4) and hex flange locknuts (#3). Do not tighten locknuts.
3. Adjust tailwheel arms to desired locations. Tighten locknuts (#3) to the correct torque.

#### Tailwheel Lift Options (3-Point)

The cutter is shipped with an attached ratchet jack or hydraulic cylinder. Hydraulic hoses and stroke control spacers are included with the hydraulic cylinder.

Screw on quick attach couplings (couplings supplied by customer) to hydraulic hose ends if hydraulic option was installed.

The ratchet jack option requires no additional set-up instructions.

#### Hitch Assembly (3-Point)

### ! WARNING

To avoid serious injury or death:

Always secure cutter with an overhead crane, fork lift, or other suitable lifting device before removing hardware bags, shipping components, bands, lag screws, or hitch pins. The cutter can suddenly fall.

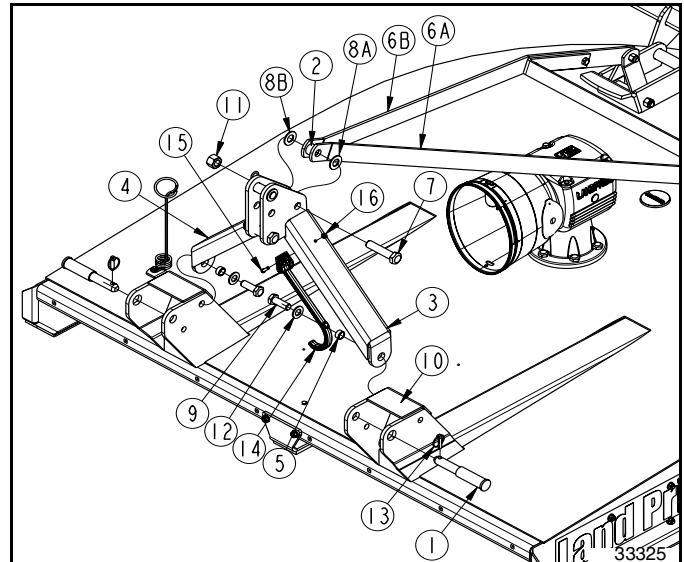

3-Point Hitch Assembly  
Figure 1-4

Refer to Figure 1-4:

1. Attach left and right-hand A-frames (#3 & #4) to cutter deck with 7/8"-9 x 2 1/2" GR5 bolts (#9), flat washers (#12), bushings (#5), and nylock nuts (#10) as shown. Tighten nylock nuts to the correct torque.
2. Insert 1"-8 x 4 1/2" GR5 cap screw (#7) through left-hand A-frame (#3), flat washer (#8A), rear brace bar (#6A), 1" long spacer (#2), rear brace bar (#6B), flat washer (#8B), and right-hand A-frame (#4). Secure cap screw with nylon insert nut (#10). Tighten hex nuts to the correct torque.
3. Attach driveline hook (#14) to A-frame (#3) using 5/16"-18 x 1 1/4" bolt (#15) and locknut (#16).
4. Insert hitch pins (#1) into clevis holes as shown and secure with linchpins (#13).



## Section 1: Assembly & Set-Up

### Hitch Arrangements (3-Point)

The center link hardware shipped attached to the hitch assembly can be arranged four different ways to fit the tractor's Cat. II or Cat. III 3-point hitch or a Cat. II or Cat. III Quick Hitch.

**NOTE:** The hitch assembly is shipped from the factory ready for hooking-up to the tractor's Cat. III 3-point hitch. See Figure 1-6.

### Category II Hitch (3-Point)

Refer to Figure 1-5:

1. Store 3 3/16" long hitch tube shown in Figure 1-6 in a location where it can be found later should the cutter be hitched to a tractor with Cat III 3-point hitch.
2. Insert 1" diameter clevis pin through middle holes of hitch clevis and flat washer as shown in Figure 1-5.
3. Secure clevis pin and flat washer with hairpin cotter.
4. Do not remove 1" cap screw and bushing from bottom hitch holes.

### Category III Hitch (3-Point)

Refer to Figure 1-6:

1. Insert 1" diameter clevis pin through Cat. III hitch tube, upper holes of hitch clevis, and flat washer as shown.
2. Secure clevis pin and flat washer with hairpin cotter.

### Category II Quick Hitch (3-Point)

Refer to Figure 1-7:

1. 1" clevis pin, hitch tube, flat washer, and hairpin cotter shown in Figure 1-6 can be stored in the upper hole of the hitch clevis as shown or stored in a location where they can be found later should the cutter be hitched directly to the tractor's 3-point lower arms and center link.
2. Attach left and right-hand hitch frames together using the bottom holes in the clevis plates with 1"-8 x 4 1/2" GR5 hex head cap screw, 2 1/16" long bushing, and hex nylock nut. Tighten nylock nut to the correct torque.

### Category III Quick Hitch (3-Point)

Refer to Figure 1-8:

1. 1" Clevis pin, hitch tube, flat washer, and cotter pin shown in Figure 1-6 must be stored in a location where they can be found later should the cutter be hitched directly to the tractor's 3-point hitch arms and center link.
2. Attach left and right-hand hitch frames together using the middle holes in the clevis plates with 1"-8 x 4 1/2" GR5 hex head cap screw, 2 1/16" long bushing, and hex nylock nut. Tighten nylock nut to the correct torque.

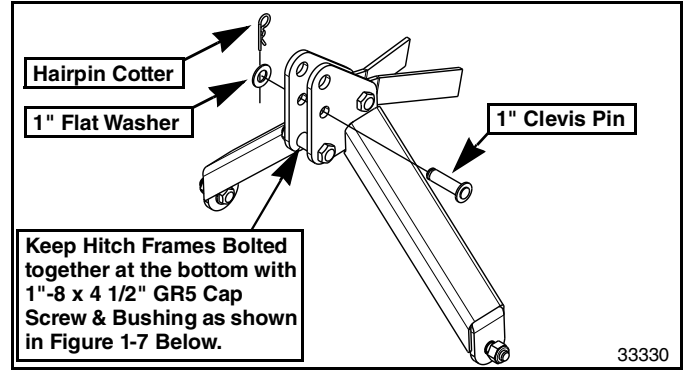

Category II 3-Point Center Link Hitch Arrangement  
Figure 1-5

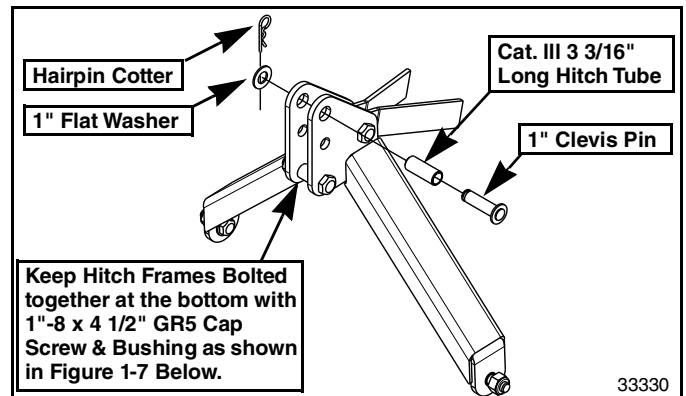

Category III 3-Point Center Link Hitch Arrangement  
Figure 1-6

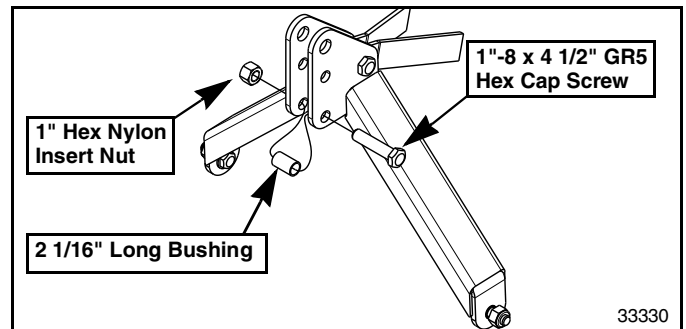

Category II Quick Hitch Center Hitch Arrangement  
Figure 1-7

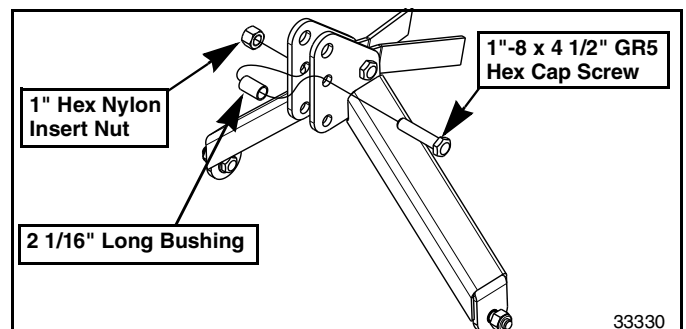

Category III Quick Hitch Center Hitch Arrangement  
Figure 1-8

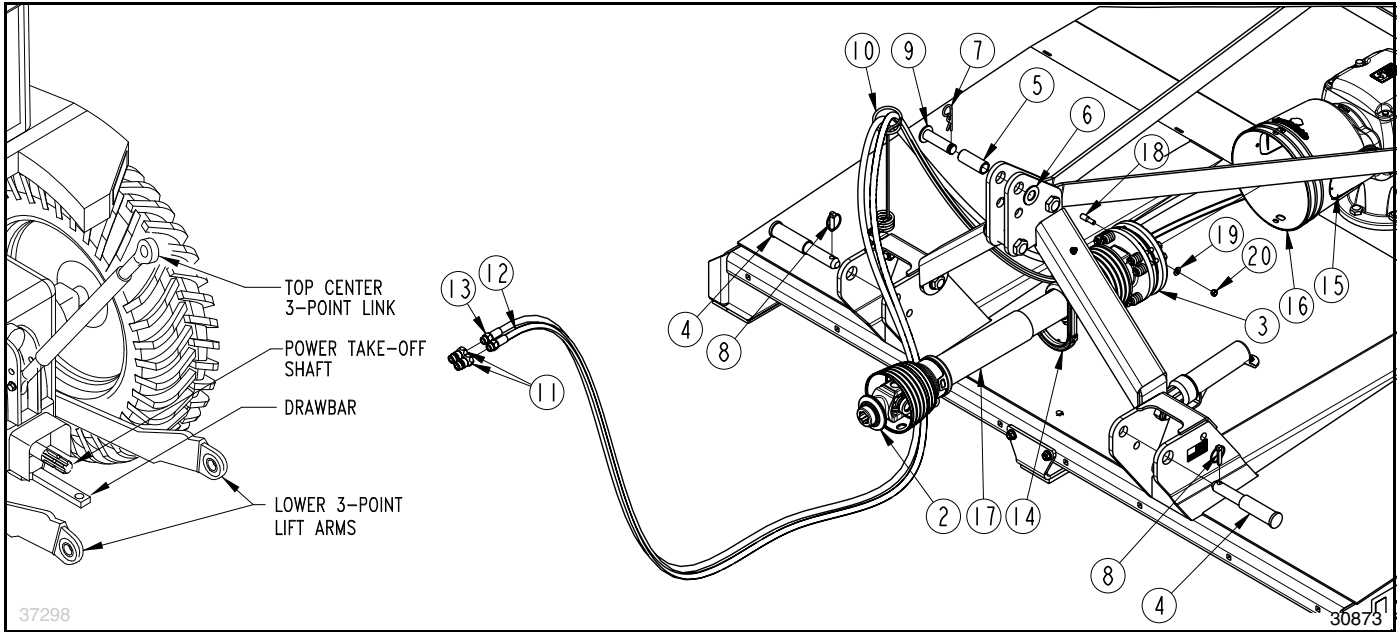

**Category III 3-Point Hook-up Arrangement Shown**  
 (See Page 13 For All Hitch Arrangements)  
 Figure 1-9

### Driveline Installation (3-Point)

Refer to Figure 1-9:

#### DANGER

To avoid serious injury or death:

Make certain driveline yokes are securely fastened at each end. A loose yoke can work free allowing the driveline to rotate uncontrollably causing implement damage and bodily injury or death to anyone nearby.

**IMPORTANT:** The drivelines must be lubricated before putting them into service. Refer to “Lubrication Points” on page 46.

1. Park tractor on a level surface. Slowly engage tractor 3-point lift lever to raise cutter until gearbox input shaft is in line and level with the tractor’s power take-off shaft.
2. Place gear selector in park, set park brake, shut tractor off, and remove switch key.
3. Support cutter deck at this height with support jacks or blocks to keep cutter from drifting down.
4. Remove tapered pin set (#18, #19 & #20) from end of slip-clutch (#17).
5. Unsnap one end of access doors (#15) and rotate doors open.
6. Slide slip-clutch end of driveline (#17) onto gearbox input shaft until hole in slip-clutch aligns with groove in gearbox input shaft.
7. With concave surface of tapered pin (#18) facing towards the gearbox shaft, insert tapered pin, and secure with removed washer (#19) and nut (#20). Tighten nut to the correct torque.

8. Move slip-clutch back and forth several times to make sure it is locked onto the gearbox shaft.
9. Collapse driveline (#2) by pushing on tractor end of driveline towards the cutter gearbox shaft.
10. Rotate driveline hanger (#14) down and support driveline (#17) on the hanger.
11. Rotate access doors (#15) closed and snap in place.

### Hitch Hook-up (3-Point)

Refer to Figure 1-9:

#### DANGER

To avoid serious injury or death:

- A crushing hazard exists while hooking-up and unhooking the implement. Keep people and animals away while backing-up to the implement or pulling away from the implement. Do not operate hydraulic controls while a person or animal is directly behind the power machine or near the implement.
- All guards and shields must be installed and in good working condition while operating the implement.
- Do not engage power take-off while hooking-up or unhooking the driveline, or while someone is standing near the driveline. A person’s body and/or clothing can become entangled in the driveline.

#### WARNING

To avoid serious injury or death:

Always follow “Tractor Shutdown Procedure” provided in this manual before dismantling the tractor.

## Section 1: Assembly & Set-Up

**IMPORTANT:** The tractor's lower 3-point arms must be stabilized to prevent side-to-side movement. Most tractors have sway blocks or adjustable chains for this purpose.

**NOTE:** Land Pride's QH20 Cat. II Quick Hitch can be attached to the tractor to provide quick and easy 3-point hook-up and detachment. See your nearest Land Pride dealer to purchase a QH20 Quick Hitch.

A tractor with 3-point Category II or III hitch is required. The lower 3-point arms must be stabilized to prevent side-to-side movement. Most tractors have sway blocks or adjustable chains for this purpose.

1. Slowly back tractor to the Rotary Cutter while using tractor's 3-point hydraulic control lever to align lower 3-point arm hitch holes with clevis hitch pin holes.
2. Engage tractor park brake, shut tractor engine off, and remove key before dismounting from tractor.
3. Attach lower 3-point arms to clevises with hitch pins (#4). Secure hitch pins with linchpins (#7).
4. Connect upper center 3-point link hitch hole to upper hitch with clevis pin (#9), bushing (#5), and hairpin cotter (#7).
5. Return to tractor, slowly and carefully raise lower cutter to ensure drawbar, tires, and other equipment on the tractor do not contact cutter frame. Move or remove drawbar if it interferes with the cutter.
6. Manually adjust one of the lower lift arms up or down to level the Rotary Cutter from left to right.
7. Manually adjust length of top-center-link to align center hitch pin vertically above lower hitch pins. Final deck leveling adjustments will be made later.
8. Adjust stabilizers on the tractor's lower 3-point arms to stop lateral float. Please consult your tractor's manual for adjusting instructions.

### Driveline Hook-up (3-Point)

#### **DANGER**

*To avoid serious injury or death:*

- Do not engage power take-off while hooking-up or unhooking the driveline, or while someone is standing near the driveline. A person's body and/or clothing can become entangled in the driveline.
- All guards and shields must be installed and in good working condition while operating the implement.
- Make certain driveline yokes are securely fastened at each end. A loose yoke can work free allowing the driveline to rotate uncontrollably causing implement damage and bodily injury or death to anyone nearby.
- Do not use a power take-off adapter. The adapter will increase strain on the tractor's power take-off shaft causing possible damage to shaft and driveline. It will also defeat the purpose of the tractor's power take-off shield.

#### **WARNING**

*To avoid serious injury or death:*

- Check driveline when lowering implement to make sure it does not interfere with the tractor drawbar at maximum depth. If needed, shut tractor off and move or remove drawbar to prevent driveline damage.
- Always follow "Tractor Shutdown Procedure" provided in this manual before dismounting the tractor.

**IMPORTANT:** The drivelines must be lubricated before putting them into service. Refer to "Lubrication Points" on page 46.

**IMPORTANT:** An additional driveline may be required if implement is attached to more than one tractor or if a Quick Hitch is used.

**IMPORTANT:** Drivelines with friction clutches must go through a "run-in" prior to initial use and after long periods of inactivity. For detailed instructions, see "Driveline Slip-Clutch" on page 42.

**IMPORTANT:** Check driveline minimum collapsible length before completing "Driveline Hook-up (3-Point)". Structural damage to the tractor and cutter can occur if this check is not made. Refer to "Check Driveline Collapsible Length" on page 16.

1. If driveline collapsible length and/or maximum length has not been checked, go to "Check Driveline Collapsible Length" and/or "Check Driveline Maximum Length" on page 17. Otherwise, continue with step 2 below.
2. Park tractor on a level surface.
3. Shut tractor down before dismounting. Refer to "Tractor Shutdown Procedure" on page 35.

#### **Refer to Figure 1-9 on page 14:**

4. If tractor drawbar interferes with the driveline during hook-up, disconnect driveline and move drawbar forward, to the side, or remove.
5. Remove driveline (#17) from driveline support (#14). Driveline support is spring loaded and will rotate up against the A-frame.
6. Pull back on driveline yoke collar (#2) and push driveline yoke onto the tractor power take-off shaft. Release pull collar and continue to push driveline yoke forward until pull collar locks in place.
7. Pull on driveline yoke collars at the tractor and implement end to make sure it is secured to the tractor power take-off shaft and implement gearbox shaft.
8. Continue with "Hydraulic Hook-up (3-Point)" on page 16.

## Section 1: Assembly & Set-Up

### Hydraulic Hook-up (3-Point)

#### **WARNING**

To avoid serious injury or death:

Hydraulic fluid under high pressure can penetrate the skin and/or eyes causing a serious injury. Wear protective gloves and safety glasses or goggles when working with hydraulic systems. Use a piece of cardboard or wood rather than hands when searching for leaks. A doctor familiar with this type of injury must treat the injury within a few hours or gangrene may result. **DO NOT DELAY.**

Refer to **Figure 1-9** on page 14:

1. Make sure spring support loop (#10) is securely fastened to the hitch frame.
2. Route hydraulic hoses (#12 & #13) through spring support loop (#10) and connect to tractor outlets.
3. Cycle hydraulic lift cylinder as follows:
  - a. Fully extend hydraulic lift cylinder and hold control lever in the extended position for 20 seconds after hydraulic cylinder has fully extended.
  - b. Fully retract hydraulic lift cylinder and hold control lever in the retracted position for 20 seconds after hydraulic cylinder has fully retracted.
  - c. Repeat steps a-b above until hydraulic cylinder operates smoothly.
4. Continue with **“Check Driveline Interference”** on page 18.

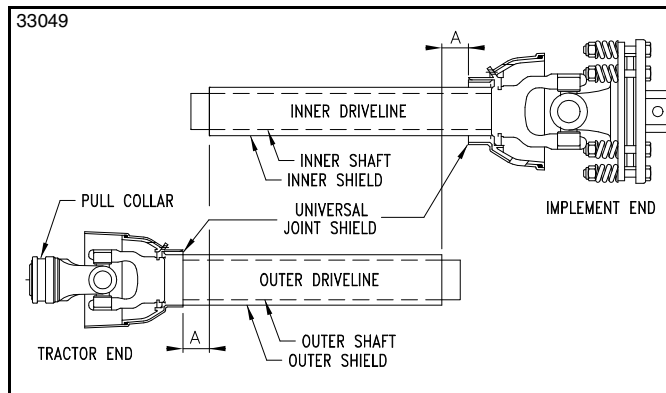

**Check Driveline Minimum Length**  
**Figure 1-10**

### Check Driveline Collapsible Length

**IMPORTANT:** A driveline that is too long can bottom out causing structural damage to the tractor and implement. Always check driveline minimum length during initial setup, when connecting to a different tractor, and when alternating between using a quick hitch and a standard 3-point hitch. More than one driveline may be required to fit all applications.

1. With driveline attached only to the cutter, remove outer driveline (tractor end) from inner driveline to separate the two profiles.
2. Park tractor and cutter on a level surface.
3. Raise cutter until gearbox input shaft is level with tractor power take-off shaft. Securely block cutter at this height to keep the unit from lowering.
4. With cutter resting on the support blocks, shutdown the tractor using **“Tractor Shutdown Procedure”** on page 35.
5. Attach outer driveline to the tractor’s power take-off shaft. Refer to step 6 under **“Driveline Hook-up (3-Point)”**.
6. Hold inner and outer drivelines parallel to each other as shown in Figure 1-10. Measure dimension “A”.
  - If “A” is less than 1”, continue with step 7 on page 17.
  - If “A” is greater than or equal to 1”, skip to **“Check Driveline Maximum Length”** on page 17.



Section 1: Assembly & Set-Up

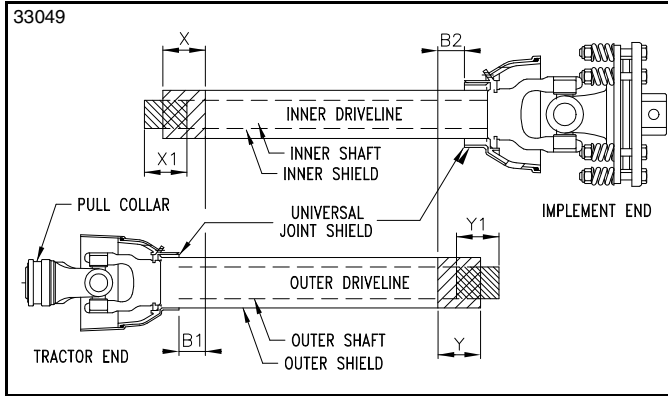

**Shorten Driveline Length**  
Figure 1-11

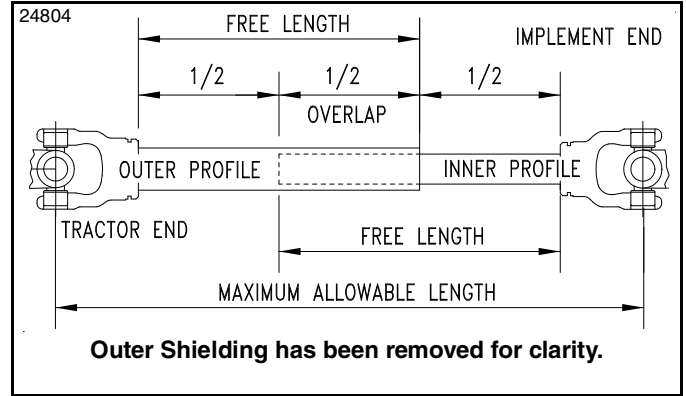

**Driveline Maximum Extended Length**  
Figure 1-12

7. If dimension “A” is less than 1”, shorten driveline as follows:

**Refer to Figure 1-11:**

- a. Measure 1” (“**B1**” dimension) back from outer driveline shield and make a mark at this location on the inner driveline shield.
  - b. Measure 1” (“**B2**” dimension) back from the inner driveline shield and make a mark at this location on the outer driveline shield.
8. Remove outer driveline from the tractor power take-off shaft and inner driveline from the cutter gearbox shaft.
9. Cut off non-yoke end of inner driveline as follows:
- a. Measure from end of inner shield to scribed mark (“**X**” dimension) and record.
  - b. Cut off inner shield at the mark. Cut same amount off the inner shaft (“**X1**” dimension).
10. Cut off non-yoke end of outer driveline as follows:
- a. Measure from end of outer shield to scribed mark (“**Y**” dimension) and record.
  - b. Cut off outer shield at the mark. Cut same amount off the outer shaft (“**Y1**” dimension).
11. Remove all burrs and cuttings.
12. Continue with “**Check Driveline Maximum Length**” on page 17.

**Check Driveline Maximum Length**

**Refer to Figure 1-12:**

The driveline maximum allowable length must, when fully extended, have a minimum overlap of profile tubes by not less than 1/2 the free length with both inner and outer profile tubes being of equal length.

1. Apply multi-purpose grease to the inside of the outer shaft and reassemble the driveline.
2. Assemble the outer and inner driveline profiles together with just 1/2 overlapping of the profile tubes as shown. Once assembled, measure and record maximum allowable length here. \_\_\_\_\_
3. Install clutch end of the driveline to the implement’s gearbox shaft. Refer to “**Driveline Installation (3-Point)**” on page 14.
4. Hook-up opposite end of the driveline to the tractor’s power take-off shaft. Refer to steps 6-7 under “**Driveline Hook-up (3-Point)**” on page 15
5. Continue with “**Hydraulic Hook-up (3-Point)**” on page 16.

## Section 1: Assembly &amp; Set-Up

## Check Driveline Interference

Refer to Figure 1-13:

 **WARNING**

To avoid serious injury or death:

A rotating driveline must not exceed an angle of 25 degrees up or down, and never engage a driveline while at an angle exceeding 25 degrees up or down. The driveline can break and send projectiles.

1. Lubricate driveline If it has not be lubricated. Refer to “**Lubrication Points**” on page 47.
2. Attach driveline to the implement or tractor if it is not attached. See “**Driveline Installation (3-Point)**” on page 14 and “**Driveline Hook-up (3-Point)**” on page 15.
3. Start tractor and raise implement slightly off the support blocks. Drive forward until the implement is clear of the support blocks.
4. Slowly and carefully lower and raise cutter to ensure drawbar, tires, and other tractor equipment do not contact the cutter frame. If there is an interference:
  - a. Back cutter over the support blocks and lower it onto the blocks.
  - b. Shut tractor down before dismounting. Refer to “**Tractor Shutdown Procedure**” on page 35
  - c. Move or remove drawbar if it interferes with the cutter and make any other necessary corrections.
  - d. Repeat steps 1-4 to verify the cutter does not interfere with the tractor.
5. Start tractor and raise implement fully up. If implement is not above the support blocks, back implement over the support blocks. Do not lower implement onto the support blocks.
6. Without changing the 3-point lift height, shut tractor down using “**Tractor Shutdown Procedure**”.
7. Check to make sure the driveline angle does not exceed 25 degrees above horizontal as shown in Figure 1-13.
8. If driveline angle exceeds 25 degrees above horizontal or if length recorded in step 2 on page 17 is exceeded, adjust 3-point lift height as follows:
  - a. Adjust tractor 3-point lift limiter height to keep the driveline within the recommended 25 degree angle and maximum allowable length.
  - b. If the 3-point left lever does not have a lift height limiter, make a mark with tape or other means to indicate maximum lift height.
9. Start tractor, raise implement slightly, and drive forward enough to clear the support blocks.
10. Lower implement to ground and shut tractor down using “**Tractor Shutdown Procedure**”.

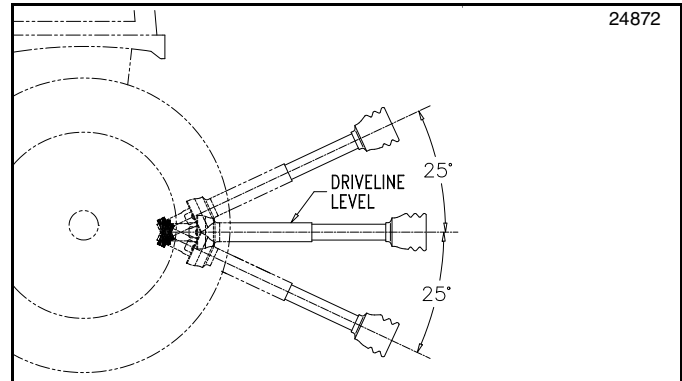

Maximum Driveline Movement During Operation  
Figure 1-13

Section 1: Assembly & Set-Up

**Pull-Type Cutter Assembly & Set-up**

The following instructions are for assembling the Pull-Type cutter. See page 12 for “3-Point Cutter Assembly & Set-up” instructions.

**Axle Assembly**

Refer to Figure 1-14:

1. Attach left and right-hand tailwheel arms (#1 & #2) to axle (#3) with 5/8"-11 u-bolts (#10) and hex lock nuts (#5). Do not tighten locknuts.
2. Adjust tailwheel arms to desired locations. Tighten locknuts (#5) to the correct torque.
3. Attach tailwheels (#12) to tailwheel arms (#1 & #2) with 1/2"-20 hex flange locknuts (#6). Tighten locknuts to the correct torque.
4. Attach leveling rod to axle lug with 3/4" x 1 1/2" clevis pin (#9), flat washer (#7), and cotter pin (#8). Bend one or more legs of cotter pin to keep it from falling out.

**Tailwheel Lift Options (Pull-Type)**

The cutter is shipped with an attached ratchet jack or hydraulic cylinder. Hydraulic hose and stroke control spacers are included with the hydraulic cylinder.

If hydraulic option was installed, screw on a quick attach coupling to hydraulic hose end (coupling supplied by customer).

The ratchet jack option requires no additional set-up instructions.

**Spring Hose Loop (Pull-Type)**

Refer to Figure 1-15:

5. Attach hose holder bracket (#1) to right-hand clevis with 3/4"-10 1 1/2" GR5 cap screw (#3) and hex locknut (#5). Tighten locknut to the correct torque.
6. Attach spring hose loop (#7) to hose holder bracket with 3/8"-16 x 1" GR5 cap screw (#2), flat washer (#6), and locknut (#4). Tighten locknut to the correct torque.

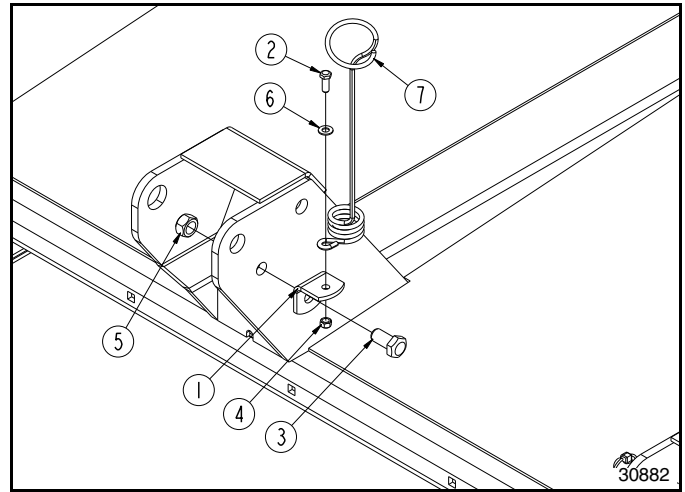

Spring Hose Loop Assembly  
Figure 1-15

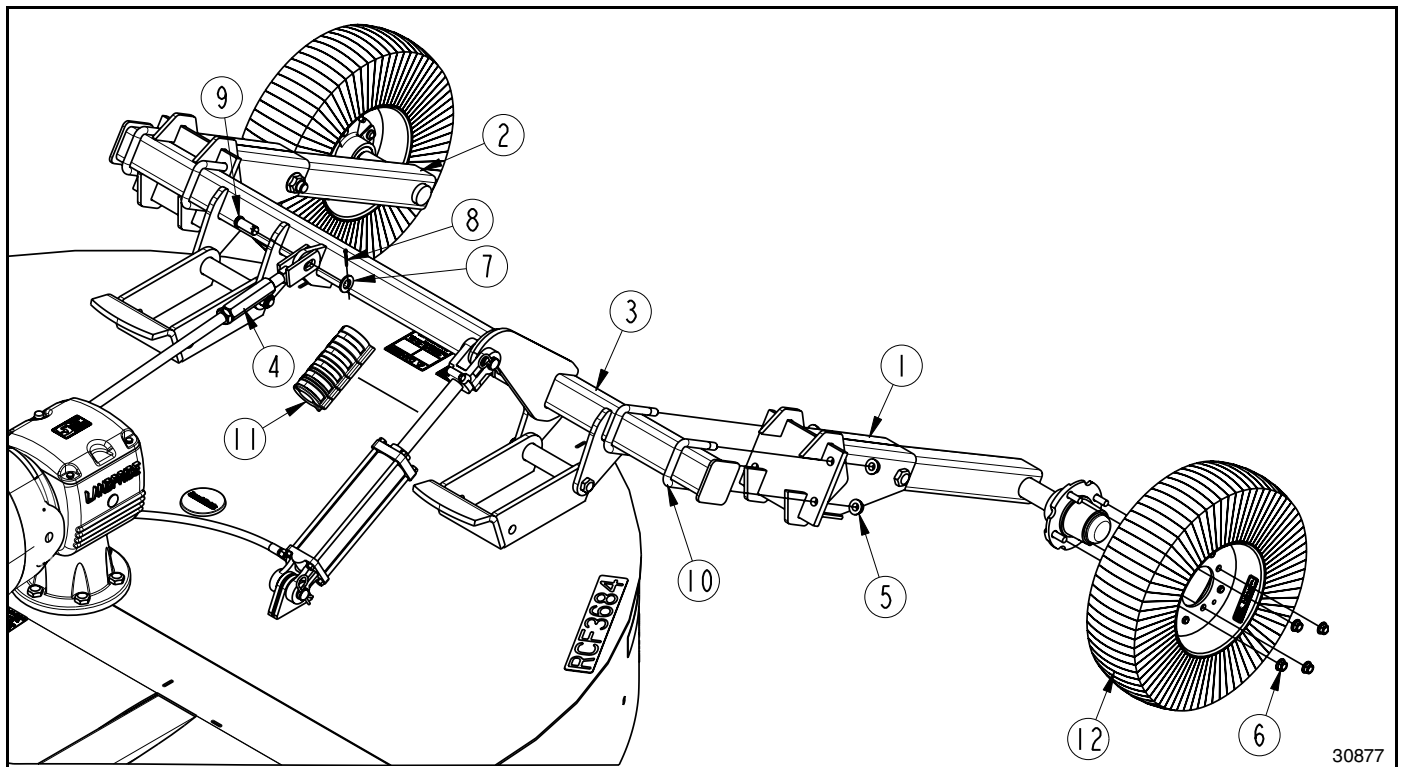

Pull-Type Axle Assembly  
Figure 1-14

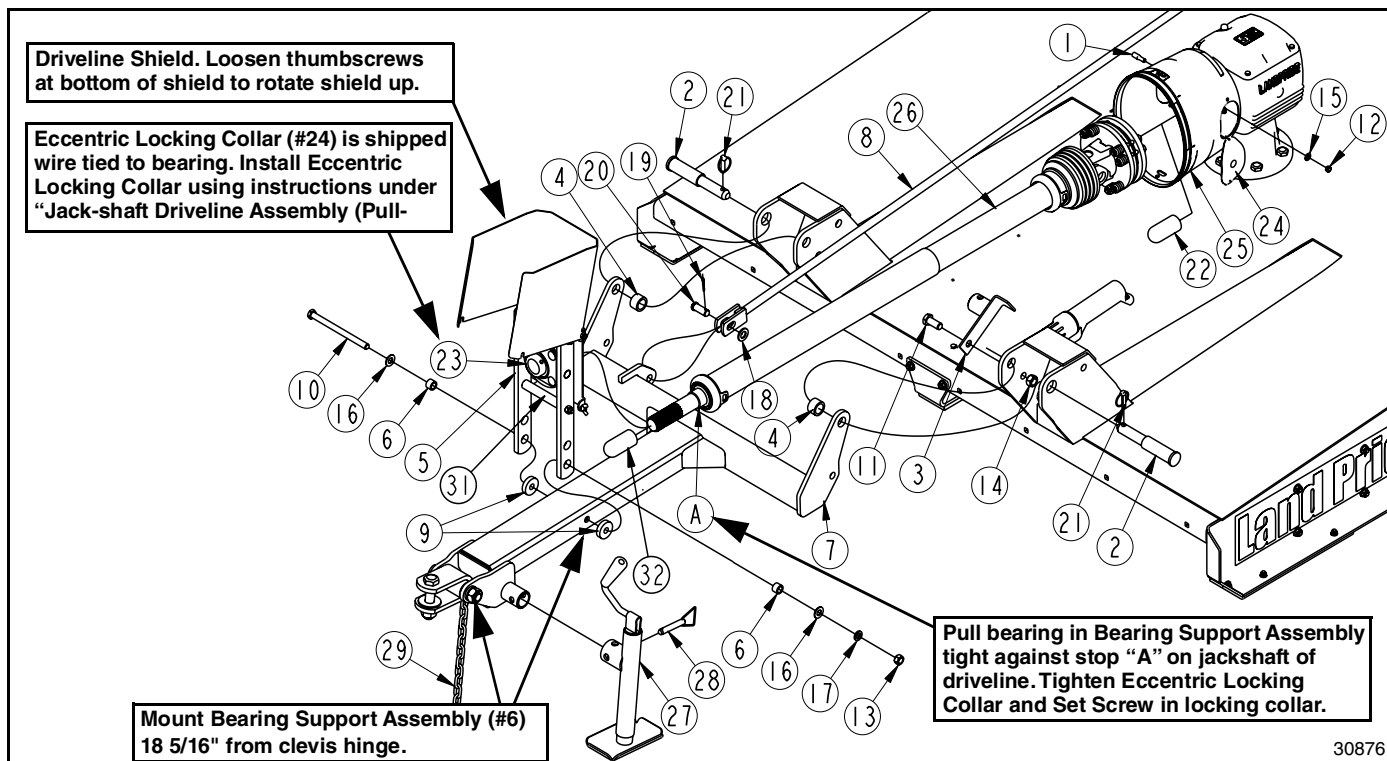

**Pull-Type Tongue Assembly**  
Figure 1-16

### Hitch Assembly (Pull-Type)

**Refer to Figure 1-16:**

1. Attach parking jack support stob (#3) to lower hole of left-hand clevis with 3/4"-10 x 1 3/4" GR5 hex head cap screw (#11) and locknut (#14). Tighten locknut to the correct torque.
2. Attach tongue (#7) to deck with hitch pins (#2) and 1" long spacers (#4). Secure hitch pins with linchpins (#21).
3. Attach leveling rod (#8) to tongue (#7) with clevis pin (#20) and hairpin cotter (#19). Bend one or more legs of hairpin cotter to keep pin from falling out.
4. Attach parking jack (#27) to jack stob on tongue with detent hitch pin (#28). Make certain detent hitch pin is fully inserted.

**NOTE:** Bearing Support assembly (#7) is mounted 18 5/16" from clevis hinge. It may be necessary to loosen bolt (#31) and spread bearing assembly (#5) apart at the bottom to install spacers (#9).

5. **Refer to Figure 1-17 on page 21:**  
If needed, loosen thumb screws (#4) and rotate driveline shield (#2) up as shown.
6. **Refer to Figure 1-16:**  
Attach bearing support assembly (#5) to tongue (#7) with 5/8"-11 x 8 1/2" GR5 hex head cap screw (#10), flat washers (#16), bushings (#6), spacers (#9), lock washer (#17), and hex nut (#13) in the order shown. Tighten hex nut (#13) to the correct torque.

## Section 1: Assembly & Set-Up

### Jack-shaft Driveline Assembly (Pull-Type)

Refer to Figure 1-16 on page 20:

**IMPORTANT:** The drivelines must be lubricated before putting them into service. Refer to “**Lubrication Points**” on page 46.

1. Remove rubber protective sleeve (#22) from gearbox input shaft and discard.
2. Remove tapered pin set (#1, #12, & #15) from end of slip-clutch.
3. Unsnap one end of both access doors (#24) and rotate doors open.
4. Slide slip-clutch end of driveline (#26) onto gearbox input shaft until hole in slip-clutch aligns with groove on gearbox shaft.
5. With concave surface of tapered pin (#1) facing towards gearbox shaft, insert tapered pin and secure with removed washer (#15) and nut (#12). Tighten nut to the correct torque.
6. Move slip-clutch back and forth several times to make certain it is locked onto the gearbox shaft.
7. Rotate access doors (#24) closed and snap in place.
8. **Refer to Figure 1-17 on page 21:**  
If not done, loosen thumb screws (#4) and rotate driveline shield (#2) up as shown.
9. **Refer to Figure 1-16:**  
Insert jackshaft end of driveline (#26) through bearing in bearing support assembly.
10. Slide eccentric locking collar (#23) over jackshaft.
11. Pull bearing tight **against stop “A”** on driveline jackshaft. Hold bearing in this position and hand tighten eccentric lock collar (#23) clockwise.
12. Continue tightening eccentric lock collar by placing a punch against hole in side of locking collar. Tap on end of punch with a hammer several times.
13. Tighten set screw in eccentric lock collar to keep collar from working loose.

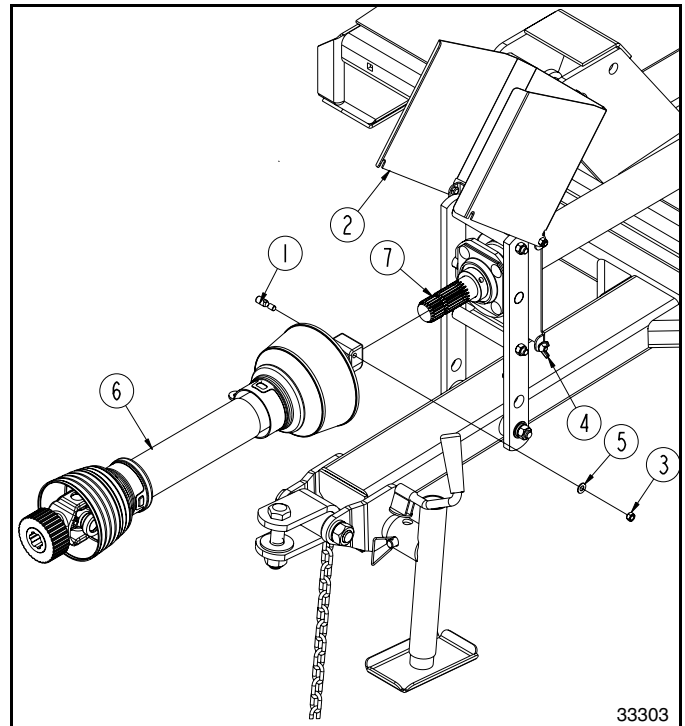

Front Driveline Assembly  
Figure 1-17

### Front Driveline Assembly (Pull-Type)

Refer to Figure 1-17:

#### DANGER

To avoid serious injury or death:

Make certain driveline yokes are securely fastened at each end. A loose yoke can work free allowing the driveline to rotate uncontrollably causing implement damage and bodily injury or death to anyone nearby.

**IMPORTANT:** The drivelines must be lubricated before putting them into service. Refer to “**Lubrication Points**” on page 46.

1. Loosen thumb screws (#4) and rotate driveline shield (#2) up as shown.
2. Remove tapered pin set (#1, #3 & #5) from end of driveline (#6).
3. Slide driveline (#6) onto jackshaft of driveline (#7) until hole in driveline (#6) aligns with groove on jackshaft.
4. With concave surface of tapered pin (#1) facing towards jackshaft, insert tapered pin and secure with removed washer (#5) and nut (#3). Tighten nut to the correct torque.
5. Move driveline yoke back and forth several times to make sure yoke is locked in place.
6. Rotate driveline shield (#2) down and hand tighten wing nuts (#4).



Section 1: Assembly & Set-Up

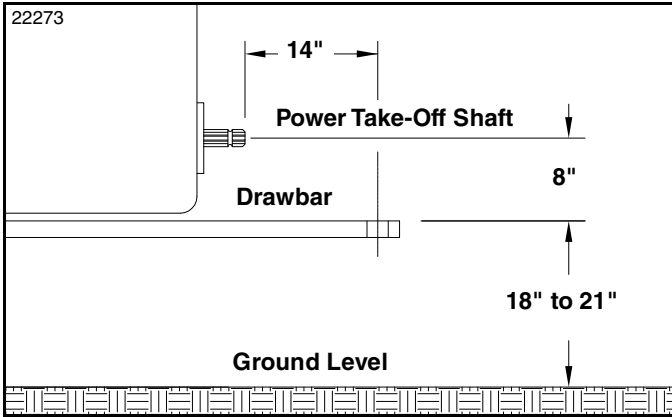

Power Take-Off to Drawbar Distance  
Figure 1-18

Hitch Hook-up (Pull-Type)

Refer to Figure 1-18:

**IMPORTANT:** Equipment damage can occur if distance from end of tractor power take-off shaft to center of drawbar hitch pin hole is not 14".

Adjust drawbar length so that center of drawbar hitch pin hole and end of tractor power take-off shaft is 14".

**! DANGER**

To avoid serious injury or death:

- A crushing hazard exists while hooking-up and unhooking the implement. Keep people and animals away while backing-up to the implement or pulling away from the implement. Do not operate hydraulic controls while a person or animal is directly behind the power machine or near the implement.
- All guards and shields must be installed and in good working condition while operating the implement.
- Do not engage power take-off while hooking-up or unhooking the driveline, or while someone is standing near the driveline. A person's body and/or clothing can become entangled in the driveline.
- Do not use a power take-off adapter. The adapter will increase strain on the tractor's power take-off shaft causing possible damage to shaft and driveline. It will also defeat the purpose of the tractor's power take-off shield.

**! WARNING**

To avoid serious injury or death:

- Always follow "Tractor Shutdown Procedure" provided in this manual before dismounting the tractor.
- Jack must be installed on the hitch and jack attachment pin must be fully inserted and secured before working on or around an implement not hooked to the tractor drawbar.

**! CAUTION**

To avoid minor or moderate injury:

Some tractors are equipped with two power take-off speeds. Be certain your tractor's power take-off shaft is set-up to operate at 540 rpm. Do not exceed 540 rpm power take-off speed or equipment breakage may result.

Refer to Figure 1-19 on page 23:

1. Make certain jack stand (#11) is properly attached to cutter hitch and properly secured with jack pin (#12).
2. Back drawbar (#1) close to clevis hitch (#2).
3. Drawbar should fit between upper and lower clevis hitch plates. Raise or lower jack stand (#11) to align clevis hitch (#2) with tractor drawbar (#1).
4. Back tractor up to cutter hitch until holes in drawbar and clevis hitch are properly aligned.
5. Attach cutter to tractor drawbar with 1"-8 x 4 1/2" GR5 cap screw (#3), two flat washers (#4 & #5) as shown, lock washer (#6), and hex nut (#7). Tighten hex nut until lock washer is squeezed flat.
6. Lower jack stand (#11) until hitch weight is supported by drawbar. Protect jack stand from damage by removing it from the hitch and storing it on jack support stob (#13).
7. Attach hitch safety chain (#10) to the tractor frame. Adjust chain length to remove all slack except what is necessary to permit turning. Lock chain hook securely to the safety chain.
8. Pull back on driveline pull collar (#8) and push driveline onto tractor power take-off shaft. Release pull collar and continue to push driveline yoke onto tractor power take-off shaft until pull collar locks into place. Pull on driveline yoke to make certain yoke has locked in place.

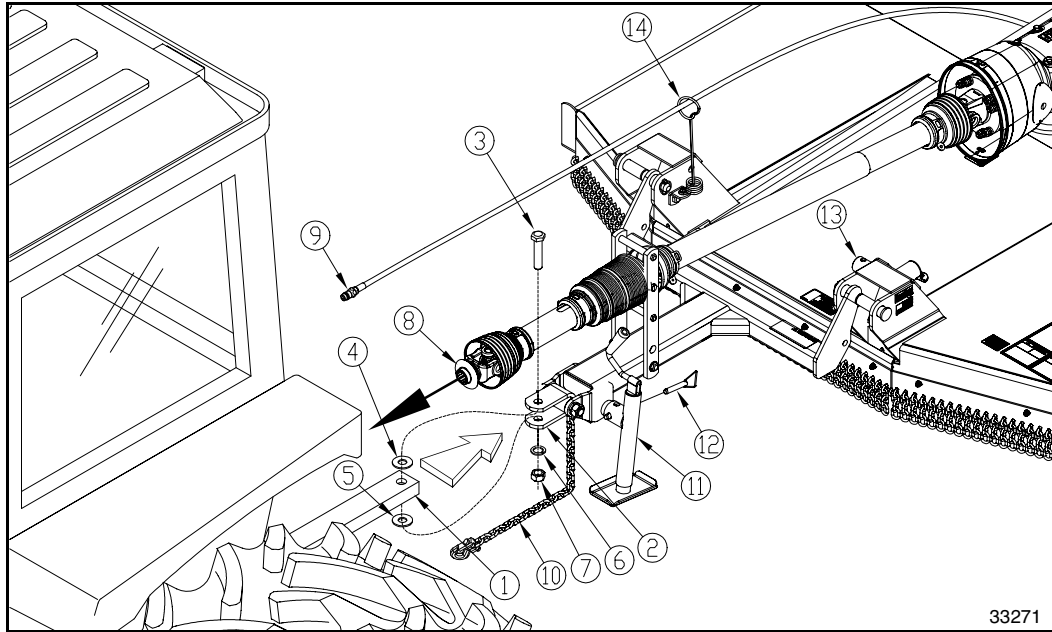

**Tractor Hook-up To Pull-Type Cutter**  
Figure 1-19

### Hydraulic Hook-up (Pull-Type)

#### **WARNING**

To avoid serious injury or death:

Hydraulic fluid under high pressure can penetrate the skin and/or eyes causing a serious injury. Wear protective gloves and safety glasses or goggles when working with hydraulic systems. Use a piece of cardboard or wood rather than hands when searching for leaks. A doctor familiar with this type of injury must treat the injury within a few hours or gangrene may result. **DO NOT DELAY.**

Refer to Figure 1-19 on page 23:

1. Make sure spring support loop (#14) is securely fastened to the hitch frame and fastener hardware is properly tightened.
2. Route cylinder hose (#9) through spring support loop (#14) and connect to tractor remote outlet.
3. Check driveline for adequate clearance under all ranges of cutter height.
  - a. With driveline attached to tractor and cutter, slowly raise and lower cutter to its upper and lower limits while observing clearances between hitch and driveline.
  - b. Adjust tractor drawbar height and/or length if driveline interferes. See Figure 1-18 on page 22 for correct drawbar dimensions.
4. Cycle hydraulic system by extending and retracting lift cylinder several times. It may be necessary to purge the hydraulic system of trapped air if operation is sluggish. Refer to “**Purge Hydraulic System (Pull-Type)**” on this page.

### Purge Hydraulic System (Pull-Type)

#### **DANGER**

To avoid serious injury or death:

Be sure deck is lowered to the ground and all hydraulic pressure is relieved before disconnecting or reconnecting hydraulic line and/or fittings between Rotary Cutter and tractor hydraulic system.

1. With deck skid shoes firmly on the ground, shut tractor off and move hydraulic control lever back and forth to relieve all hydraulic pressure in the system.
2. Loosen hydraulic hose fitting at the hydraulic cylinder slightly to allow air and fluid to escape.
3. Restart tractor and slowly activate tractor control lever to extend and retract hydraulic cylinder to purge trapped air from the hydraulic system.
4. Lower cutter down until deck skid shoes are resting firmly on the ground, shut tractor off, and move hydraulic control lever back and forth to relieve all hydraulic pressure in the hydraulic system.
5. After all air is purged from the hydraulic system and all hydraulic pressure is relieved, tighten hose fitting at the hydraulic cylinder.

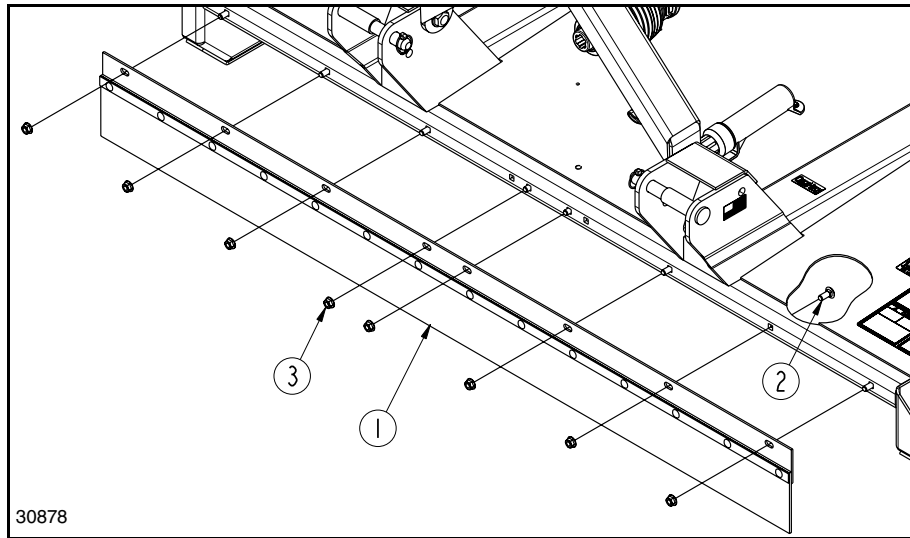

**Front Rubber Guard**  
Figure 2-1

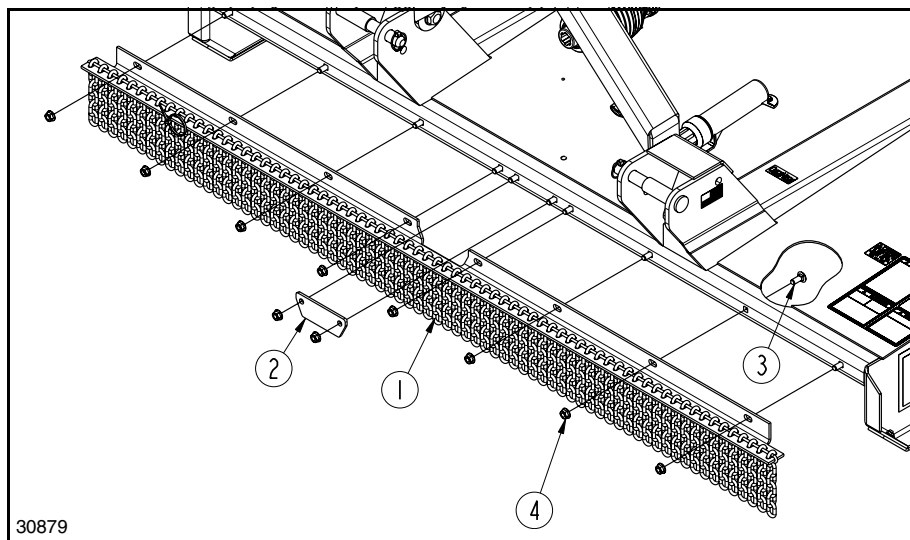

**Front Chain Guard (Single & Double Chain)**  
Figure 2-2

## Front and Rear Guard Installations

### DANGER

To avoid serious injury or death:

Rotary Cutters have the ability to discharge objects at high speeds; therefore, the use of front & rear safety guards is mandatory with this cutter. Double row chain guards should be used when cutting along roadways and in areas where people may be present. Stop blade rotation if bystanders are in or around the area. It is recommended that a safety shield be placed between the operator and cutter on an open air tractor.

### Front Rubber Guard

Refer to Figure 2-1:

1. Install front rubber guard (#1) as shown with 1/2"-13 x 1 1/4" GR5 carriage bolts (#2), and hex whiz nuts (#3).

2. Tighten all nuts to the correct torque.

### Front Chain Guard (Single & Double)

Refer to Figure 2-2:

1. Install front chain guard (#1) as shown with 1/2"-13 x 1 1/4" GR5 carriage bolts (#3), and hex whiz nuts (#4).
2. Install chain guard plug (#2) as shown with two 1/2"-13 x 1 1/4" GR5 carriage bolts (#3), and hex whiz nuts (#4).
3. Tighten all nuts to the correct torque.



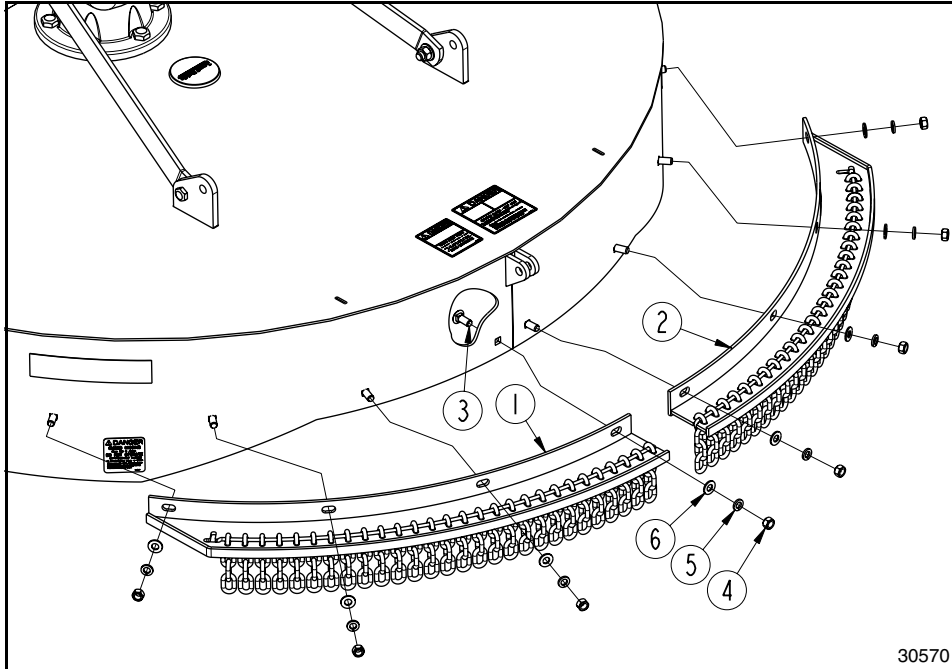

**Rear Chain Guard (Single and Double Chain)**  
Figure 2-3

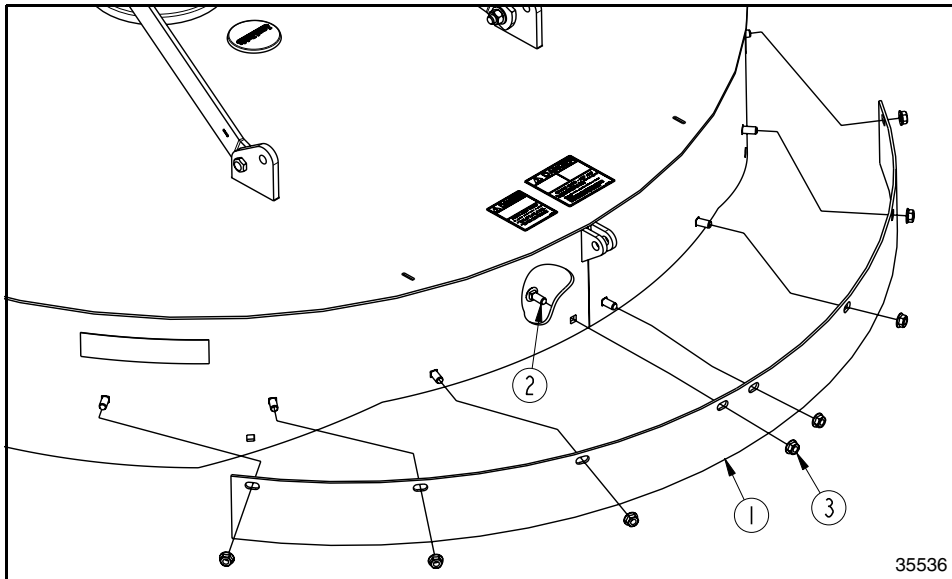

**Shredder Blades and Fixed Blades**  
Figure 2-4

### Rear Chain Guard (Single & Double)

Refer to Figure 2-3:

1. Install left-hand rear chain guard (#1) with 1/2"-13 x 1 1/4" GR5 carriage bolts (#3), flat washers (#6), spring lock washers (#5), and hex nuts (#4).
2. Install right-hand rear chain guard (#2) with 1/2"-13 x 1 1/4" GR5 carriage bolts (#3), flat washers (#6), spring lock washers (#5), and hex nuts (#4).
3. Tighten all nuts to the correct torque.

### Rear Metal Deflector

Refer to Figure 2-4:

1. Install rear metal deflector (#1) with 1/2"-13 x 1 1/4" GR5 carriage bolts (#2) and hex whiz nuts (#3).
2. Tighten all whiz nuts to the correct torque.

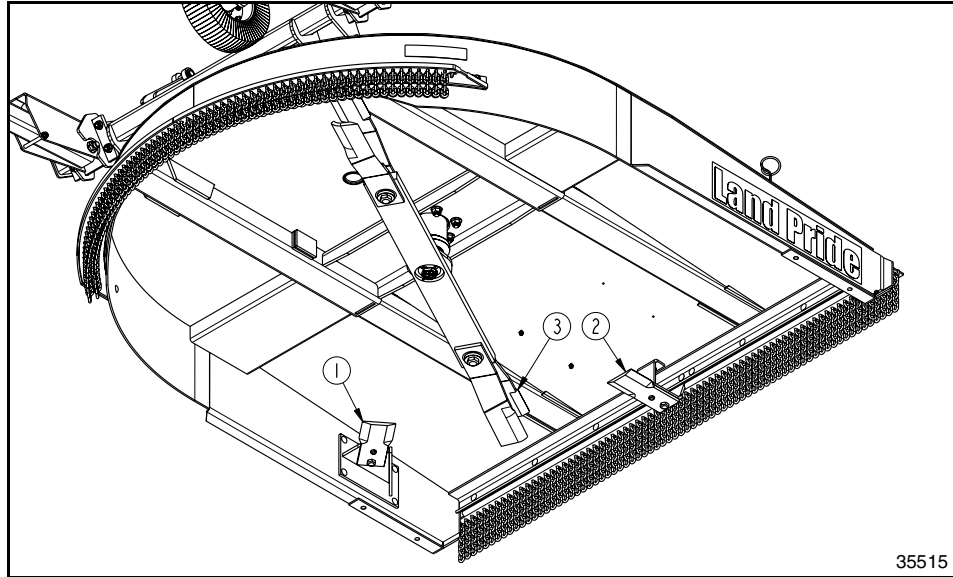

Shredder Blades and Fixed Blades

Figure 2-5

### Shredder/Fixed Blades & Baffle Kits

Refer to Figure 2-5:

The shredder blades (#3) and stationary knives (#1 & #2) for the RCF3660 & RCF3672 shredder kits are ideal for cutting residue into smaller pieces.

#### Part Number & Description

326-610A RCF3684 SHREDDER KIT

### Assembly Instructions

The shredder blades, fixed blades, and baffles are assembled at the factory if purchased with the Rotary Cutter. If purchased later, the shredder blades, fixed blades, and baffles will require assembly. The following safety precautions should be adhered during assembly.

### DANGER

To avoid serious injury or death:

- Always disconnect driveline from the tractor before servicing the drivetrain and components powered by the drivetrain. A person can become entangled in the drivetrain if the tractor is started and the power take-off is engaged.
- Always secure equipment with solid, non-concrete supports before working under it. Never go under equipment supported by concrete blocks or hydraulics. Concrete can break, hydraulic lines can burst, and/or hydraulic controls can be actuated even when power to hydraulics is off.

1. Raise wings fully up and lock into position with transport locks.
2. Raise deck fully up and place support jacks under the four corners of the center deck. Lower center deck onto the support jacks.
3. Place tractor gear selector in park and/or set brakes, shut engine off and remove ignition key.
4. Disconnect main driveline from the tractor's power take-off shaft.

### Removal of Existing Blade Carriers

Refer to Figure 2-6

1. Remove cotter pin (#4), slotted hex nut (#3), flat washer (#2), and blade carrier assembly (#1) from the gearbox spindle.
2. Keep removed hardware (#2, #3 & #4) for assembly of shredder blades. Store blade assembly (#1) in a clean dry location. Inside storage is best.

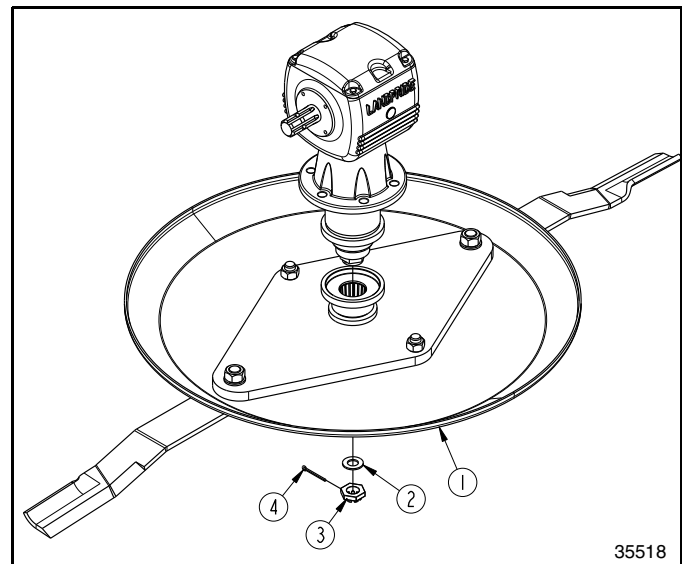

Removal of Existing Blade Carrier Assemblies

Figure 2-6

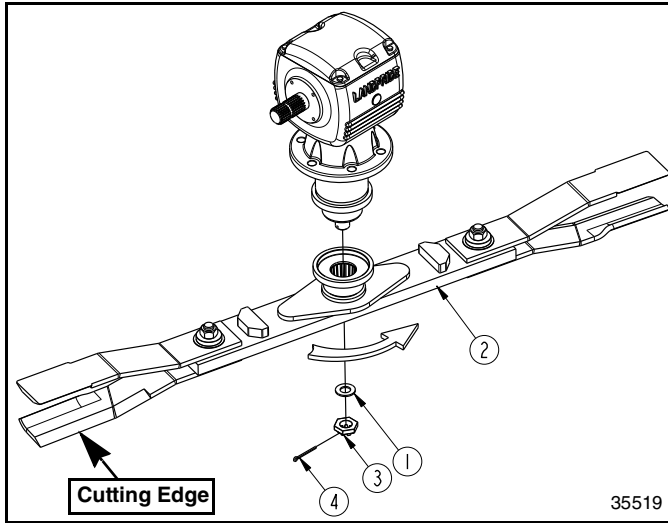

Shredder Assembly (Counterclockwise Rotation)  
Figure 2-7

### Shredder Assembly

Refer to Figure 2-7:

1. Attach shredder assembly (#2) to gearbox spindle with existing washer (#1) and slotted hex nut (#3). Torque slotted nut to 550 ft./lbs.
2. Insert existing cotter pin (#4) through slotted hex nut and gearbox spindle. Secure cotter pin by bending both legs opposite directions around slotted hex nut.

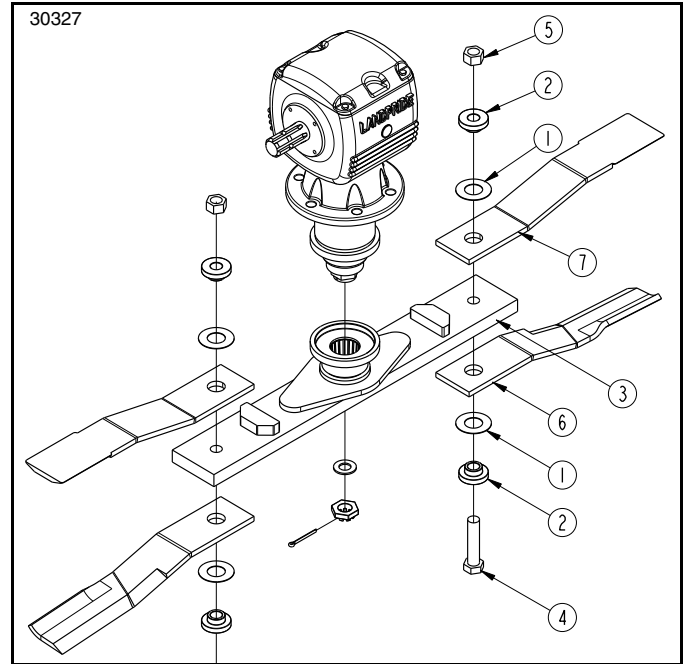

Free Vertical Movement  
Figure 2-8

### Check Free Vertical Movement of Blades

Refer to Figure 2-8:

#### WARNING

To avoid serious injury or death:

A locknut that has been removed can lose its thread locking properties. Reusing a used locknut can result in a thrown blade. Always use a new locknut when installing blades.

The cutting blades should not have more than 3/4" free vertical movement at the blade tips. If vertical movement exceeds 3/4", install or change to thicker spacers (#1) as follows. Order spacers (#1) and locknuts (#5) from your nearest Land pride dealer.

1. Check top and bottom blade deflections. If vertical deflection at either blade tip is greater than 3/4", remove blade bolt (#4) and reassemble using thicker spacers (#1). The greater the deflection, the thicker the spacer required.
2. Assemble blades by inserting 1"-8 x 4 1/2" GR8 hex head bolt (#4) through bushing (#2), spacer (#1), lower cutting blade (#6), blade carrier (#3), upper flat cutting blade (#7), spacer (#1), and bushing (#2). Temporary secure blade with a plain hex nut (Plain hex nut furnished by customer.) **Draw nut up snug. Do not tighten.**
3. Check top and bottom blade deflections again. If deflection at the blade tips are still greater than 3/4", remove blade bolt and reassemble as before with thicker spacers.
4. Once blade deflections are correct, **replace plain nut with supplied locknut (#5)** and torque to 450 ft.-lbs.

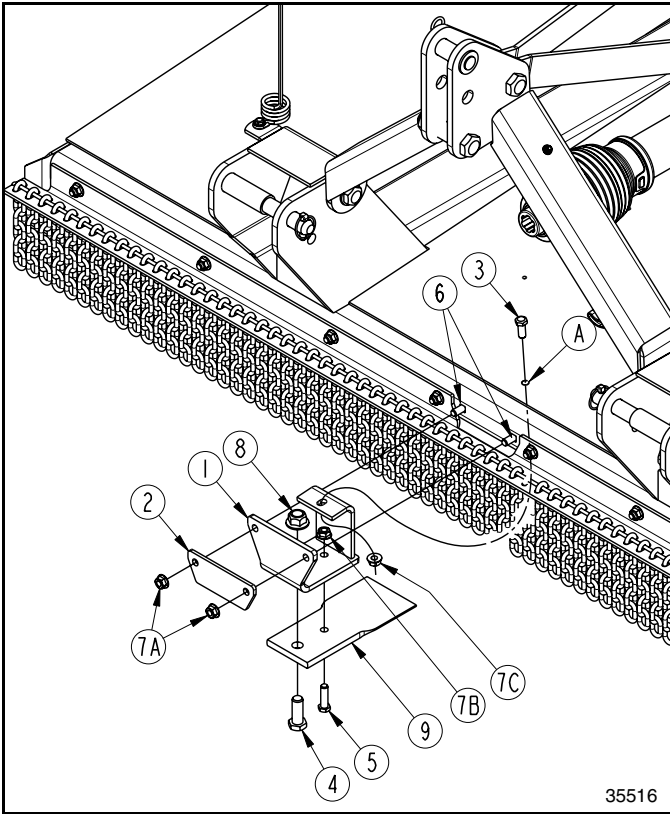

**Front Fixed Blade Assembly**  
Figure 2-9

**Front Fixed Blade Assembly**

Refer to Figure 2-9:

1. Remove existing hex whiz nuts (#7A), chain guard plug (#2), and carriage bolts (#6). Store nuts, plug, and carriage bolts for reuse should the cutter be reverted back to the original blade carrier assembly.
2. Remove knock-out plug (#A).
3. Orient beveled edges of fixed blade (#9) down and attach to front fixed blade mount (#1) as shown with one 3/4"-10 x 2" GR5 bolt (#4), one 1/2"-13 x 1 3/4" bolt (#5), one 1/2" hex whiz nut (#7B), and one 3/4" hex flange top locknut (#8). Tighten nuts (#7B & #8) to the correct torque.
4. From beneath the deck, insert front fixed blade mount (#1) through slot in the front chain guard and attach to the deck front with new 1/2"-13 x 1 1/4" GR5 carriage bolts (#6), 1/2"-13 x 1 1/4" GR5 bolt (#3), and hex whiz nuts (#7A & #7C). Tighten hex whiz nuts to the correct torque.

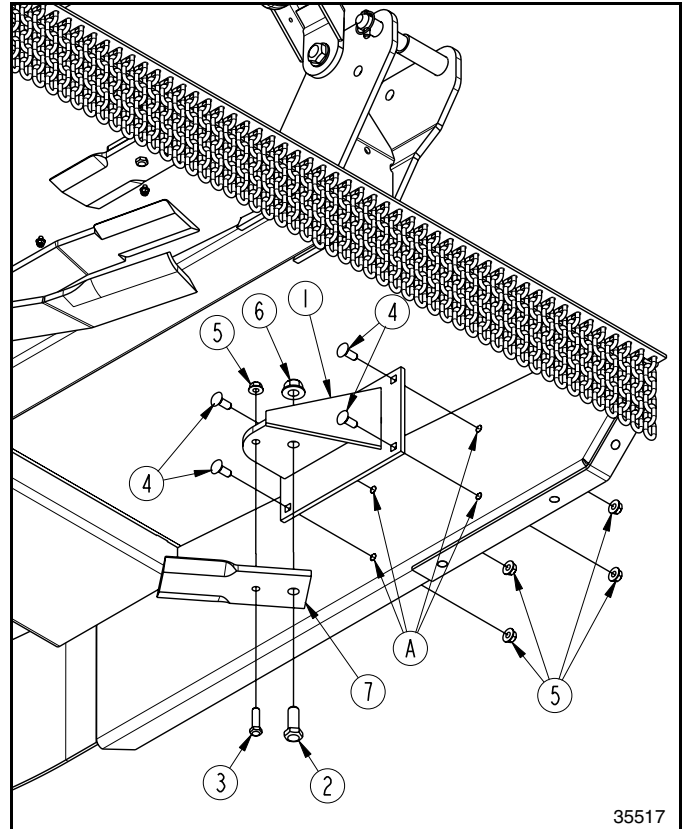

**Left Side Fixed Blade Assembly**  
Figure 2-10

**Left Side Fixed Blade Assembly**

Refer to Figure 2-10:

1. On the left-hand side panel, remove the four knock-out plugs (A) in the location shown.
2. Position beveled edges of fixed blade (#7) down and attach to left side fixed blade mount (#1) with 3/4"-10 x 2" GR5 bolt (#2), 1/2"-13 x 1 3/4" bolt (#3), 1/2" hex whiz nut (#5), and 3/4" hex flange top locknut (#6). Tighten nuts (#5 & #6) to the correct torque.
3. Attach left side fixed blade mount (#1) to the left-hand side panel with four 1/2"-13 x 1 1/4" GR5 carriage bolts (#4) and hex whiz nuts (#5). Tighten hex whiz nuts to the correct torque.

Section 3: Adjustments

**Level & Set Deck Height (3-point)**

The following instructions are for leveling the 3-point cutter. See page 31 for “**Level & Set Deck Height (Pull-Type)**” instructions.

There are four primary adjustments that should be made prior to actual field operation:

- “**Level Left to Right (3-Point)**” on page 29
- “**Cutting Height (3-Point)**” on page 29
- “**Tailwheel Height (3-Point)**” on page 30
- “**Center 3-Point Link (3-Point)**” on page 30

Proper adjustment of each will provide for higher efficiency, improved cutting performance, and longer blade life. Pliable tape measure, spirit or carpenters level, and protective gloves will be needed:

**WARNING**

*To avoid serious injury or death:*

*Always follow “Tractor Shutdown Procedure” provided in this manual before dismantling the tractor.*

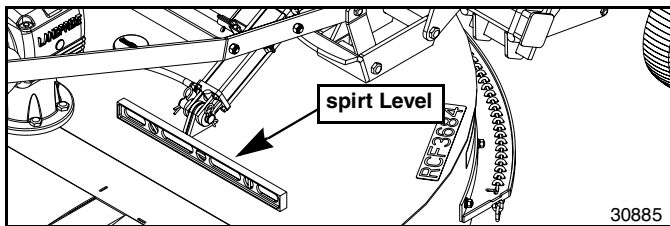

**Deck Leveling**  
Figure 3-1

**Level Left to Right (3-Point)**

Refer to Figure 3-1:

1. Locate tractor with cutter on a flat, level surface.
2. Use tractor’s hydraulic 3-point control lever to lower cutter until tailwheels makes contact with the ground.
3. Place a level on the cutter deck as shown. Manually adjust one or both lower 3-point lift arms vertically until deck is level from left to right. On some tractors, only one arm can be adjusted.

**Cutting Height (3-Point)**

Refer to Figure 3-2:

**WARNING**

*To avoid serious injury or death:*

*Avoid direct contact with cutter blades by wearing a pair of gloves. Cutter blades have sharp edges and burrs that can cause injuries.*

**IMPORTANT:** The front blade tip should be lower than rear blade tip by approximately 1". The cutter is subject to continuous material flow under the deck if the rear blade is at the same height or lower than the front blade causing horsepower loss, grass clumps, blade wear, and frequent blade sharpening.

1. With gloves on, carefully rotate blades and stump jumper until blade tips are at the front and back of cutter as shown.
2. Measure distance from cutting tip of front blade to the ground. This distance is the cutting height.
3. Using tractor’s 3-point hydraulic control, raise or lower 3-point lift arms until the front blade tip is at the desired cutting height.
4. The 3-point center link should be loose when deck rear is supported by the tailwheel. If not, lengthen 3-point center link until loose. Final adjustment will be made later.
5. Measure distance from cutting tip of rear blade to ground. This distance should be slightly higher than the front blade but not more than 1" higher.
6. If rear blade is lower than front blade or higher than the front blade by more than 1", then tailwheel height must be adjusted. If needed, see “**Tailwheel Height (3-Point)**” instructions on page 30.
7. Repeat steps 1 through 6 until tailwheel and 3-point arms are adjusted to the desired cutting height.
8. Set tractor’s 3-point hydraulic control stop to the desired cutting height.

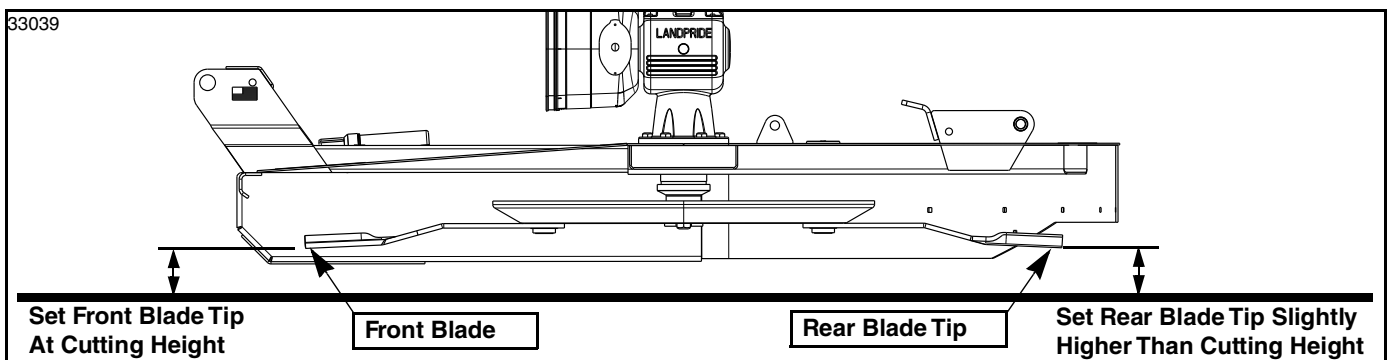

**3-Point Deck Leveling & Cutting Height**  
Figure 3-2



## Section 3: Adjustments

### Tailwheel Height (3-Point)

#### **WARNING**

To avoid serious injury or death:

Avoid direct contact with cutter blades by wearing a pair of gloves. Cutter blades have sharp edges and burrs that can cause injuries.

**NOTE:** Removing spacers (#3) lowers the cutting height and adding spacers raises the cutting height.

If front blade tip is set at the desired cutting height and back blade tip is at the same height or lower or is higher than the front blade tip by more than 1", then the tailwheels must be adjusted up or down as follows:

#### Ratchet Jack

Refer to Figure 3-3:

Change rear blade height with ratchet jack as follows:

1. Setting ratchet jack lock and pumping ratchet jack lever back and forth until rear blade height is slightly higher than front blade tip but by not more than 1".

#### Hydraulic Cylinder

Refer to Figure 3-4:

Change rear blade height hydraulically as follows:

1. With tractor hydraulics, raise cutter fully up.
2. Remove all stroke control spacers (#3) from cylinder rod (#1) by spreading spacers apart at the break line.
3. Using tractor control lever for the hydraulic cylinder, lower Rotary Cutter until rear blade height is slightly higher than front blade tip but not by more than 1".
4. Select required size and number of stroke control spacers (#3) that will fill the exposed cylinder rod. The following spacers are available:  
Two 1" spacers, one 1 1/4" spacer, one 1 1/2" spacer, and one 1 3/4" spacer
5. Return to the tractor and raise Rotary Cutter up. Install selected size and number of stroke control spacers on the cylinder rod.
6. Lower Rotary Cutter against stroke control spacers and recheck cutting height. If needed, adjust size and quantity of stroke control spacers until desired cutting height is achieved.

#### Center 3-Point Link (3-Point)

Refer to Figure 3-5:

**NOTE:** The lower bolted-on-bushing in the center hitch is used with a Quick Hitch attachment.

1. Lower cutter deck to preset cutting height.
2. For optimum ground contour following performance, adjust length of center 3-point link until center hitch pin is vertically above lower 3-point hitch pins.
3. Lock center 3-point link in this position.

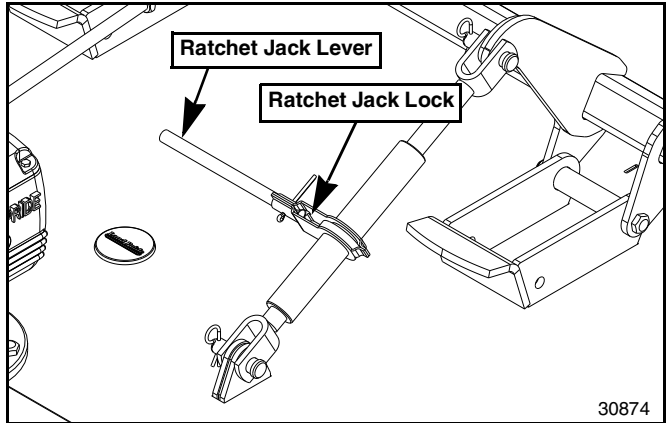

Ratchet Jack Height Adjustment  
Figure 3-3

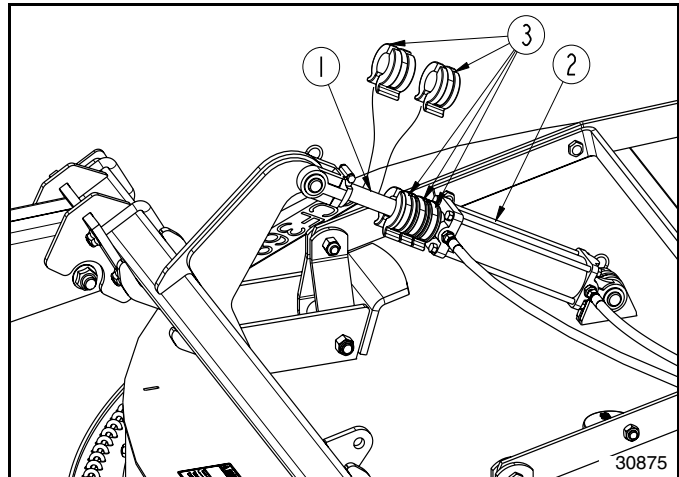

Hydraulic Cylinder Height Adjustment  
Figure 3-4

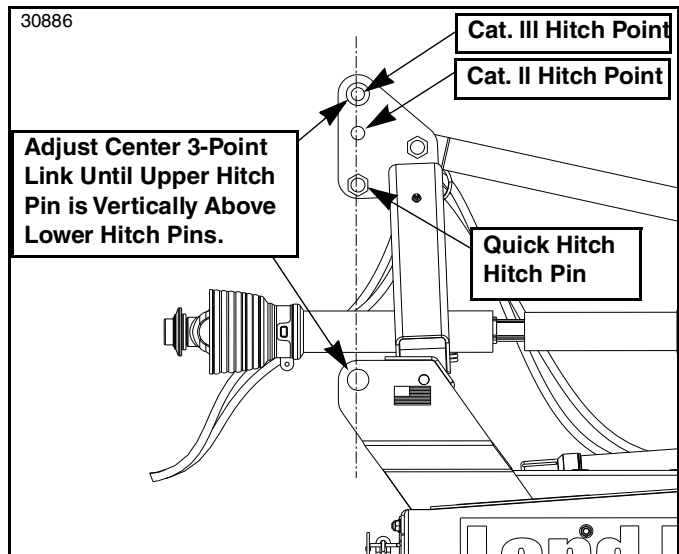

Center 3-Point Link Adjustment  
Figure 3-5

Section 3: Adjustments

**Level & Set Deck Height (Pull-Type)**

The following instructions are for leveling the Pull-Type cutter. See page 29 for “**Level & Set Deck Height (3-point)**” instructions.

There are two primary adjustments that should be made prior to actual field operation:

- “**Level Front To Back (Pull-Type)**” on page 31
- “**Cutting Height (Pull-Type)**” on page 31

Proper adjustment of each of these items will provide for higher efficiency, improved cutting performance, and longer blade life. Pliable tape measure, spirit or carpenter’s level, set of wrenches, and protective gloves will be needed:

**! WARNING**

*To avoid serious injury or death:*

*Always follow “Tractor Shutdown Procedure” provided in this manual before dismantling the tractor.*

**Level Front To Back (Pull-Type)**

This adjustment should be made with cutter hooked to the tractor that will be used for field operations or to one having the same drawbar height and length. Adjust leveling rods as described below.

**NOTE:** The tip of the front blade should be lower than the tip of the rear blade. If front and rear blades are at the same height or if rear blade is lower than the front blade, then the cutter is subject to continuous material flow under the deck resulting in loss of horsepower, additional blade wear, and frequent blade sharpening.

Refer to Figure 3-6:

1. Attach cutter to the tractor that will be pulling the cutter and position tractor and cutter on level ground.
2. With gloves on, carefully rotate blades and stump jumper until blade tips are in the position shown.
3. Using tractor control lever, adjust deck height so that the front blade tip is 3 to 4 inches above ground.

Refer to Figure 3-8:

**NOTE:** Lengthen leveling rod (#1) to raise cutter rear and shorten leveling rod to lower cutter rear.

4. Measure distances the front blade and rear blade tips are off the ground. The deck is properly leveled when rear blade tip is slightly higher than front blade tip but not by more than 1".

**If rear blade tip is too low:**

- a. Loosen jam nut (#2) several turns.
- b. Unscrew hex coupler nut (#3) clockwise (direction shown by arrow) to raise cutter rear.
- c. Re-tighten jam nut (#2) against coupler nut (#3) when height of rear blade tip is acceptable.

**If rear blade tip is too high:**

- a. Loosen jam nut (#2) several turns or more.
- b. Tighten hex coupler nut (#3) counterclockwise (opposite direction shown by arrow) to lower cutter rear until height of rear blade tip is acceptable.
- c. Re-tighten jam nut (#2) against coupler nut (#3).

**Cutting Height (Pull-Type)**

**! WARNING**

*To avoid serious injury or death:*

- *Avoid direct contact with cutter blades by wearing a pair of gloves. Cutter blades have sharp edges and burrs that can cause injuries.*
- *Always follow “Tractor Shutdown Procedure” provided in this manual before dismantling the tractor.*

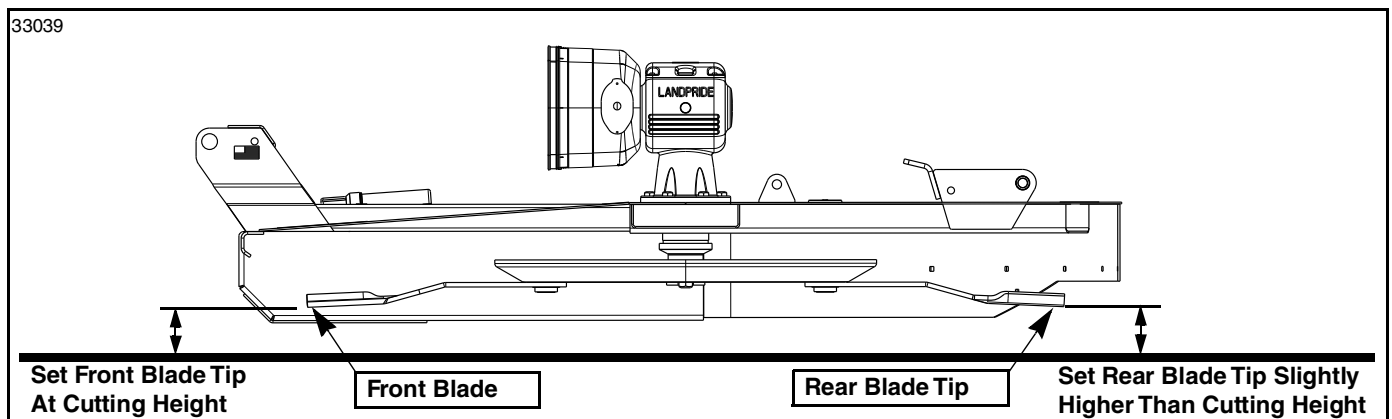

**Pull-Type Deck Leveling & Cutting Height**  
Figure 3-6

## Section 3: Adjustments

### Ratchet Jack

Refer to Figure 3-7:

At the front of the cutter, measure distance from tip of front cutting blade to ground. This distance is the cutting height. Use ratchet jack to change cutting height.

1. Raise cutter blades by setting ratchet jack lock and pumping ratchet jack lever back and forth to lengthen ratchet jack until desired cutting height is achieved.
2. Lower cutter blades by reposition ratchet lock and pumping ratchet jack lever back and forth to shorten ratchet jack until desired cutting height is achieved.

### Hydraulic Cylinder

Refer to Figure 3-8:

At the front of the cutter, measure distance from tip of blade to ground. This distance is the cutting height. Use tractor hydraulic control lever to change cutting height.

1. With tractor hydraulics, raise cutter fully up.
2. Remove all stroke control spacers (#5) from cylinder rod (#4) by spreading spacers apart at the break line.
3. Using tractor hydraulic cylinder control lever, lower Rotary Cutter to the desired cutting height. Measure this distance to verify cutting height is correct.
4. Select required size and number of stroke control spacers (#5) that will fill the exposed cylinder rod. The following spacers are available.
  - Two 1" spacers
  - One 1 1/4" spacer
  - One 1 1/2" spacer
  - One 1 3/4" spacer
5. Return to the tractor and raise Rotary Cutter up. Install selected size and number of stroke control spacers on the cylinder rod.
6. Lower Rotary Cutter against stroke control spacers and recheck cutting height. If needed, adjust size and quantity of stroke control spacers until desired cutting height is achieved.

**NOTE:** Removing spacers lowers the cutting height and adding spacers raises the cutting height.

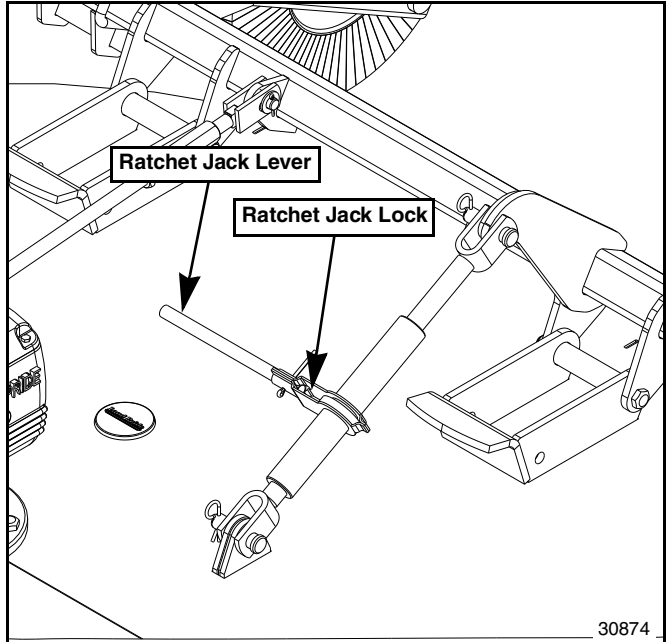

**Ratchet Jack Adjustment  
Figure 3-7**

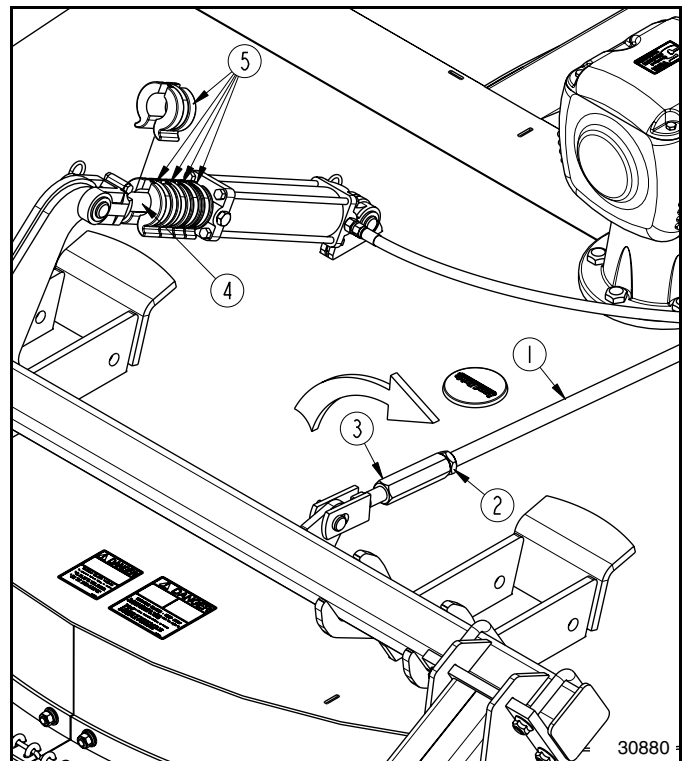

**Deck Leveling & Hydraulic Height Adjustments  
Figure 3-8**



Section 4: Operating Instructions

**Operating Checklist**

Hazard control and accident prevention are dependent upon awareness, concern, prudence, and proper training involved in the operation, transport, maintenance, and storage of the Rotary Cutter. Therefore, it is absolutely essential that no one operates the Rotary Cutter unless they are age 16 or older and have read, fully understood, and are totally familiar with the Operator’s Manual. Make sure the operator has paid particular attention to:

- **Important Safety Information**, pages 1 to 4
- **Section 1: Assembly & Set-Up**, page 11
- **Section 2: Optional Equipment Set-Up**, page 24
- **Section 3: Adjustments**, page 290
- **Section 4: Operating Instructions**, page 33

Perform the following inspections before using your Rotary Cutter.

**Operating Checklist**

✓	Check	Page
	Make sure all guards and shields are in place. Refer to “Important Safety Information”.	1
	Follow hook-up & driveline install instructions. See “Section 1: Assembly & Set-Up”.	11
	Make all required adjustments. Refer to “Section 3: Adjustments”.	29
	Perform all required maintenance. Refer to “Section 5: Maintenance & Lubrication”.	40
	Lubricate cutter and driveline as needed. Refer to “Lubrication Points”.	46
	Check cutter initially and periodically for loose bolts and pins. Refer to “Torque Values Chart”.	52
	Lubricate gearbox and replace oil plugs properly. Refer to “Gearbox” lubrication.	47

**Safety Information**

 **DANGER**

To avoid serious injury or death:

- Never place hands or feet under the deck or attempt to make adjustments to the cutter with power take-off engaged. Cutter blades rotating at high speeds cannot be seen and are located close to the deck sides. Body extremities will be cut off instantly.
- Do not engage power take-off while hooking-up or unhooking the driveline, or while someone is standing near the driveline. A person’s body and/or clothing can become entangled in the driveline.
- Be sure deck is lowered to the ground and all hydraulic pressure is relieved before disconnecting or reconnecting hydraulic line and/or fittings between Rotary Cutter and tractor hydraulic system.
- All guards and shields must be installed and in good working condition while operating the implement.

- Tractor power take-off shaft shield, driveline shields, and gearbox shaft shields must be installed and in good working condition to avoid driveline entanglement and projectiles flying off of the driveline.
- Rotary Cutters have the ability to discharge objects at high speeds; therefore, the use of front & rear safety guards is mandatory with this cutter. Double row chain guards should be used when cutting along roadways and in areas where people may be present. Stop blade rotation if bystanders are in or around the area. It is recommended that a safety shield be placed between the operator and cutter on an open air tractor.
- Always disconnect driveline from power take-off shaft before servicing underside of cutter. The tractor can be started with power take-off engaged.
- Do not use a power take-off adapter. The adapter will increase strain on the tractor’s power take-off shaft causing possible damage to shaft and driveline. It will also defeat the purpose of the tractor’s power take-off shield.
- Do not use cutter as a fan. Cutting blades are not properly designed or guarded for this use.

 **WARNING**

To avoid serious injury or death:

- Allow only persons to operate this implement who have fully read and comprehended this manual, who have been properly trained in the safe operation of this implement, and who are age 16 or older. Serious injury or death can result from the inability to read, understand, and follow instructions provided in this manual.
- Do not operate and/or travel across inclines where tractor and/or implement can rollover. Consult your tractor’s manual for acceptable inclines the tractor is capable of traveling across.
- Hydraulic fluid under high pressure can penetrate the skin and/or eyes causing a serious injury. Wear protective gloves and safety glasses or goggles when working with hydraulic systems. Use a piece of cardboard or wood rather than hands when searching for leaks. A doctor familiar with this type of injury must treat the injury within a few hours or gangrene may result. DO NOT DELAY.
- Perform scheduled maintenance. Check for loose hardware, missing parts, broken parts, structural cracks, and excessive wear. Make repairs before putting the implement back into service.
- Never carry riders on the implement or tractor. Riders can obstruct the operator’s view, interfere with controls, be pinched by moving components, become entangled in rotating components, struck by objects, thrown about, fall off and be run over, etc.
- A rotating driveline must not exceed an angle of 25 degrees up or down, and never engage a driveline while at an angle exceeding 25 degrees up or down. The driveline can break and send projectiles.

## Section 4: Operating Instructions

- Always disengage power take-off before lifting cutter fully up. Never operate cutter in the raised position. The cutter can discharge objects at high speeds.
- Do not operate a broken or bent driveline. Such a driveline will break apart while rotating at high speeds and can cause serious injury or death. Always remove the implement from use until the damaged driveline can be repaired or replaced.
- Select a safe ground speed when transporting. Never travel at a speed which does not allow adequate control of steering and stopping, and never exceed 20 mph (32.2 km/h) with attached equipment. Rough terrain requires a slower speed.
- Always disengage power take-off, put tractor in park or set park brake, shut tractor engine off, remove ignition key, and wait for blades to come to a complete stop before dismounting tractor.
- Do not exceed rated cutting capacity of your cutter. See specifications & capacities for specified cutting capacity. Exceeding rated cutting capacity can damage drive components, cutter blades, and deck components.
- Improper oil level can cause bearing failure and be a fire hazard. Maintain proper gearbox oil level to avoid serious injury and property damage.
- Buildup of debris around moving components and gearboxes is a fire hazard. Keep rotating parts and gearboxes free from debris to avoid serious injury and property damage.
- Do not use implement to lift objects; to pull objects such as fence posts, stumps, etc.; or to push objects. The unit is not designed or guarded for these uses.
- Do not use implement as a man lift or work platform. It is not properly designed or guarded for this use.
- Some tractors are equipped with two power take-off speeds. Be certain your tractor's power take-off shaft is set-up to operate at 540 rpm. Do not exceed 540 rpm power take-off speed or equipment breakage may result.

### Inspect Tractor & Cutter

Make the following inspections with cutter attached to a tractor, power take-off disengaged, and all moving components completely stopped:

1. Park tractor and cutter on a level surface. Disengage tractor power take-off, place gear selector in park, set park brake, shut tractor off, and remove switch key.
2. Make sure cutter blades have come to a complete stop before dismounting from tractor.
3. Inspect tractor safety equipment to make sure it is installed and in good working condition.
4. Inspect cutter safety equipment to make sure it is installed and in good working condition. Check
5. Carefully raise and lower implement to ensure drawbar, tires, and other equipment on the tractor do not contact cutter frame or driveline.
6. Check driveline guards to make certain they are in good working condition and in place.
7. Check driveline to be sure it is securely connected to tractor power take-off shaft and cutter gearbox shaft.
8. Check all hoses and wires to be sure that they will not come in contact with rotating driveline.
9. With cutter resting on solid supports, power take-off disengaged, and blade rotation completely stopped:
  - Check for and remove foreign objects wrapped around blade spindles.
  - Check for nicked, bent, broken, and worn cutting blades. Replace or sharpen blades as required. Refer to “**Cutter Blade Maintenance**” on page 41.
10. Inspect Hydraulic hoses for wear, damage, and hydraulic leaks. See “**Avoid High Pressure Fluids Hazard**” on page 3. Replace damaged and worn hoses with genuine Land Pride parts.
11. Remove solid supports from under the deck.
12. Verify cutter height is set correctly. See “**Level & Set Deck Height (3-point)**” on page 29 or “**Level & Set Deck Height (Pull-Type)**” on page 31.

The remaining inspections are made by engaging the power take-off to check for vibrations.

### WARNING

To avoid serious injury or death:

- Stop power take-off immediately if vibration continues after a few revolutions during start-up and anytime thereafter. Wait for all components to come to a complete stop before dismounting from tractor to check for probable causes. Make necessary repairs and adjustments before continuing.
  - Some tractors are equipped with two power take-off speeds. Be certain your tractor's power take-off shaft is set-up to operate at 540 rpm. Do not exceed 540 rpm power take-off speed or equipment breakage may result.
13. Start tractor, set throttle to idle or slightly above idle, and slowly engage power take-off. Initial start-up vibration is normal and should stop after a few revolutions. Stop power take-off rotation immediately if vibration continues.
  14. Once cutter is running smoothly, increase tractor power take-off speed to 540 rpm. Stop power take-off rotation immediately if vibration occurs.
  15. Investigate cause of vibration and make repairs before putting cutter back into service.

Section 4: Operating Instructions

**Tractor Shutdown Procedure**

The following are basic tractor shutdown procedures. Follow these procedures and any additional shutdown procedures provided in your tractor Operator’s Manual before leaving the operator’s seat.

1. Reduce engine speed and disengage power take-off if engaged.
2. Park tractor and implement on level, solid ground.
3. Lower implement to ground or onto non-concrete support blocks.
4. Put tractor in park or set park brake, turn off engine, and remove switch key to prevent unauthorized starting.
5. Relieve all hydraulic pressure to auxiliary hydraulic lines.
6. Wait for all components to come to a complete stop before leaving the operator’s seat.
7. Use steps, grab-handles and anti-slip surfaces when stepping on and off the tractor.

**Transporting**

**⚠ WARNING**

To avoid serious injury or death:

- When traveling on public roadways, travel in such a way that faster moving vehicles may pass safely. Use accessory lights, clean reflectors, and a slow moving vehicle sign that is visible from the back to warn operators in other vehicles of your presence. Always comply with all federal, state, and local laws.
  - Always disengage power take-off before lifting cutter fully up. Never operate cutter in the raised position. The cutter can discharge objects at high speeds.
  - Always disengage power take-off and wait for driveline to stop rotating before raising implement to transport position.
1. Make sure driveline does not contact tractor or cutter when raising cutter to transport position.
  2. Reduce tractor ground speed when turning and leave enough clearance so cutter does not contact obstacles such as buildings, trees, or fences.
  3. Limit transport speed to 20 mph. Transport only with a tractor of sufficient size and horsepower.
  4. When traveling on roadways, transport in such a way that faster moving vehicles may pass you safely.
  5. Shift tractor to a lower gear when traveling over rough or hilly terrain.

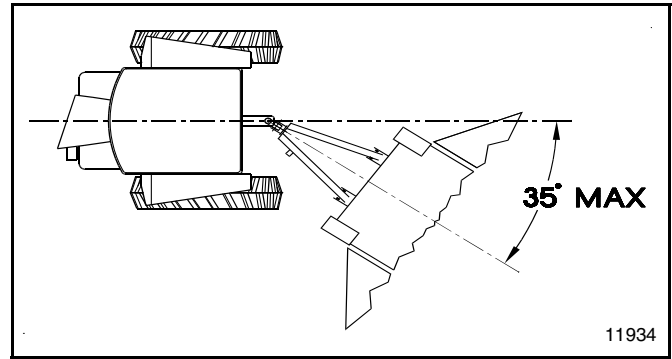

Conventional U-Joint Driveline  
Figure 4-1

**Turning Angles for Pull-Type Cutters**

Refer to Figure 4-1:

Avoid tractor-to-cutter turning angles exceeding 35 degrees if main driveline is a standard conventional drive shaft. This extreme angle is intended for intermittent usage only and not prolonged usage. Plan your field cutting to minimize the number of turns as well as extreme angles where turns are necessary.

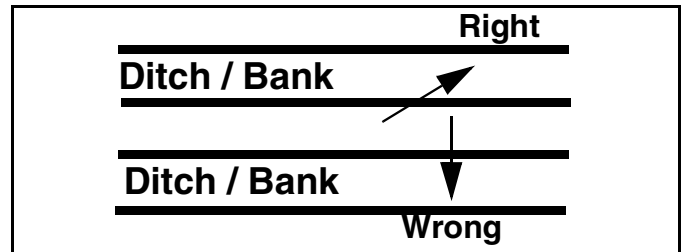

Crossing Steep Ditches and Banks  
Figure 4-2

**Crossing Steep Ditches & Banks**

Refer to Figure 4-2:

**⚠ WARNING**

To avoid serious injury or death:

Damage to the tractor’s power take-off and/or driveline can cause driveline to come loose and cause bodily injury to the operator and others.

**IMPORTANT:** Always cross ditches and banks at a diagonal. Never cross straight across and never back into a ditch or bank.

Cutting over ditches and backing up hills can tilt the cutter’s back side up excessively resulting in “**Bottoming Out**” the driveline. Bottoming out is when the driveline shaft has shorten to the point it is pressing against the gearbox and tractor power take-off shafts. Once a driveline has bottomed out, it can not be shorten anymore without causing serious damage to the tractor power take-off components, cutter gearbox, and driveline.

Do not operate a pull-type cutter at an angle exceeding 25 degrees up or down or at any angle that will force the driveline to bind and/or hit the tractor drawbar.

## Section 4: Operating Instructions

### Blade Engagement & Disengagement

Cutter blades can lock-up against each other during start-up and shut-down especially if the tractor's power take-off engagement is "INSTANT ON" and "INSTANT OFF". Following Blade Engagement and Blade Disengagement instructions on page 36 will help eliminate blade lock up.

#### Blade Engagement

1. Increase throttle to a speed just enough to get the cutter started without stalling tractor while slowly engaging power take-off drivelines. Use tractor's power take-off soft start option if available.
2. Ensure that all power shafts are rotating and that the cutter is not vibrating excessively after ramping up to power take-off speed for at least 3 seconds. If excessive vibration continues after 3 seconds at full power take-off speed, disengage power take-off immediately, shut down tractor, and remove switch key.
3. Check blades for a lock-up situation. Block cutter deck up before working under the unit. Unlock blades, remove support blocks, and repeat "Blade Engagement" instructions.

#### Blade Disengagement

1. Slowly decrease throttle speed until engine idle speed is reached and then disengage power take-off.
2. Engage tractor park brake, shut tractor engine off and remove switch key. Stay on tractor until blades have come to a complete stop.

### Field Operation

#### DANGER

To avoid serious injury or death:

- Always secure equipment with solid, non-concrete supports before working under it. Never go under equipment supported by concrete blocks or hydraulics. Concrete can break, hydraulic lines can burst, and/or hydraulic controls can be actuated even when power to hydraulics is off.
- Clear area to be cut of debris and other unforeseen removable objects before cutting. Mark non-removable hazards such as tree stumps, post stubs, protruding objects, rocks, drop-offs, holes, etc. with a visible flag.

#### WARNING

To avoid serious injury or death:

Do not back pull-type cutter into solid objects. The joint where the tongue is pinned to the deck will pivot upward causing damage to the deck and driveline.

**IMPORTANT:** Your cutter is equipped with free swinging cutting blades to reduce shock loads when striking obstacles. However, it is best to avoid striking obstacles to extend cutter and blade life.

**IMPORTANT:** Maintain correct power take-off speed. Loss of power take-off speed will allow blades to swing back resulting in ragged, uneven cutting.

**NOTE:** Do not cut in wet conditions. Wet material will build up on the deck underside creating poor discharge, high wear, and additional horsepower.

Frequently inspect cutter for loose bolts and nuts. Tighten all loose hardware as indicated in the "Torque Values Chart" on page 52.

1. Thoroughly inspect area to be cut for debris and unforeseen objects. Mark any potential hazards.
2. Follow "Blade Engagement" instructions above to start cutter blades turning.
3. Optimum ground speed depends on density of material being cut, horsepower rating of tractor, and terrain. Always operate tractor at cutter's full rated power take-off speed in a gear range that allows the cutter to make a smooth cut without lugging tractor down, usually between 2 to 5 mph.
4. Stop traveling and disengage power take-off after the first 50 feet of cutting. Check cutter levelness and cutting height to make certain it is adjusted properly.
5. Do not engage power take-off with 3-point cutter fully raised.
6. Periodically disengage power take-off, shut down tractor, remove key, and check for foreign objects wrapped around the blade spindle. Block cutter deck up before going under the deck to check and remove objects.
7. Frequently inspect cutter for loose bolts and nuts. Tighten all loose bolts and nuts as indicated in the "Torque Values Chart" on page 52.
8. See "General Operating Instructions" on page 39.



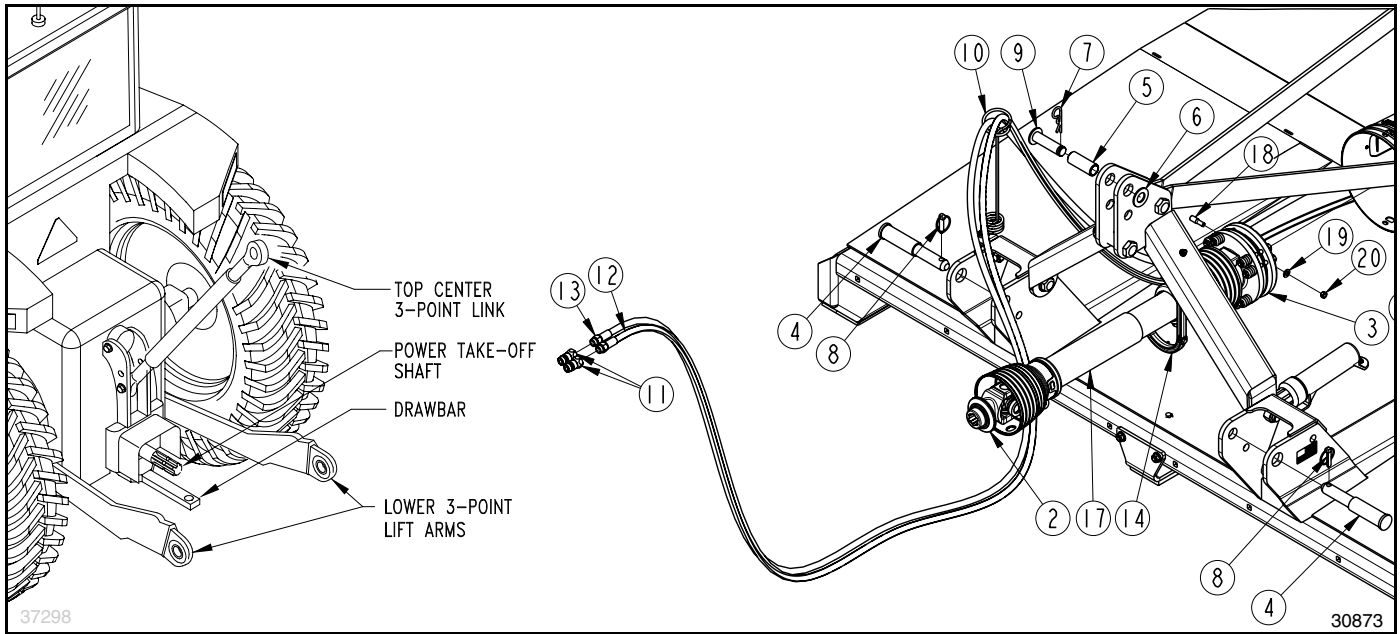

Unhook 3-Point Rotary Cutter  
Figure 4-3

### Unhook 3-Point Hitch

Refer to Figure 4-3:

#### **WARNING**

To avoid serious injury or death:

Always disengage power take-off, put tractor in park or set park brake, shut tractor engine off, remove ignition key, and wait for blades to come to a complete stop before dismantling tractor.

1. See “**Long-Term Storage**” on page 44 if cutter is to be stored for a long time.
2. Disengage power take-off, park on a level solid surface, and engage tractor park brake.
3. Lower 3-point arms until cutter is resting on the ground or support blocks.
4. Shut tractor down before dismantling. Refer to “**Tractor Shutdown Procedure**” on page 35.
5. Move cylinder lift levers back and forth to release all hydraulic pressure at the couplers.
6. Disconnect hydraulic hoses (#12 & #13) from the tractor. Insert couplers through spring hose loop (#10) to keep couplers out of the dirt.
7. Pull back on lock collar (#2) and pull driveline (#17) from tractor power take-off shaft.
8. Collapse driveline (#17) by pushing tractor end of driveline toward the cutter gearbox.
9. Rotate driveline support hook (#14) down and store driveline in the hook. Do not store driveline with yoke end in the dirt.
10. Unhook 3-point cutter hitch from the tractor lower arms and upper center link by removing hitch pins (#9 & #4).
11. Start tractor and drive slowly forward several feet while watching to make sure no components are still hooked to the tractor.
12. Shut tractor down before dismantling. Refer to “**Tractor Shutdown Procedure**” on page 35.
13. Reinstall hitch pins, linchpins, and/or hair pin cotters in the cutter 3-point hitch for safe keeping
14. Pivot top of 3-point hitch back as far as possible to store unit safely.

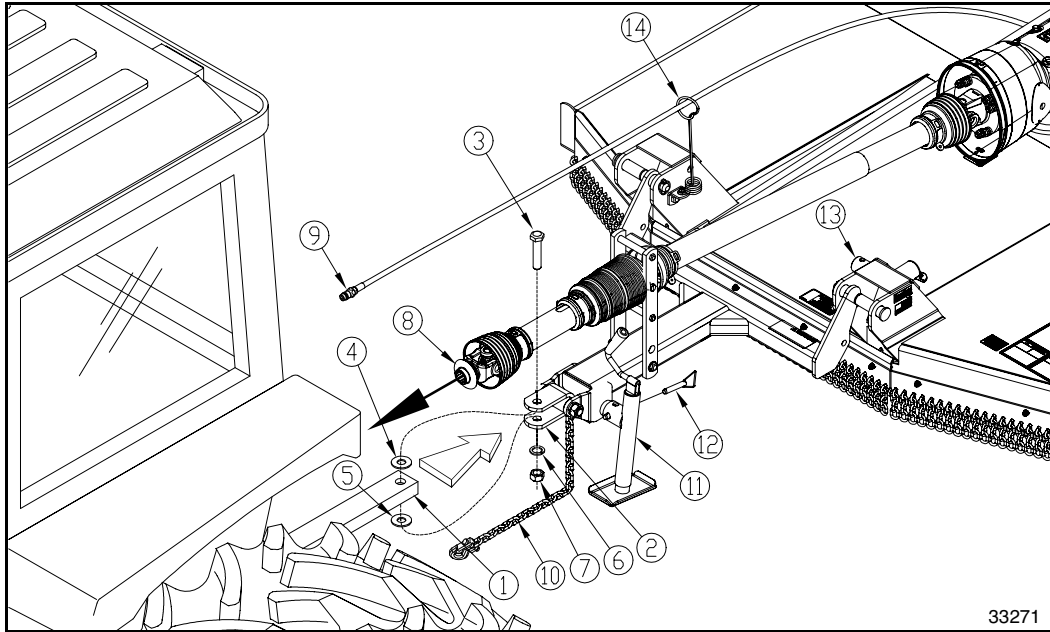

**Unhook Pull-Type Cutter**  
**Figure 4-4**

### Unhook Pull-Type Hitch

#### **WARNING**

To avoid serious injury or death:

- Always disengage power take-off, put tractor in park or set park brake, shut tractor engine off, remove ignition key, and wait for blades to come to a complete stop before dismantling tractor.

- Always place park jack on a firm surface or place a board under the park jack for additional support.

1. See “**Long-Term Storage**” on page 44 if cutter is to be stored for a long time.
2. Park cutter on a level solid hard surface. Place tractor gear selector in park or set park brake.
3. Lower cutter down until resting against the stroke control spacers on the lift cylinder.
4. Shut tractor down before dismantling. Refer to “**Tractor Shutdown Procedure**” on page 35.
5. Move cylinder lift lever back and forth to release all hydraulic pressure at the couplers.
6. Remove park jack (#11) from cutter deck mount (#13) and secure to cutter tongue by fully inserting ball detent pin (#12) through park jack and tongue mounting bracket.
7. Disconnect hydraulic hose (#9) from the tractor. Insert couplers through spring hose loop (#14) to keep couplers out of the dirt.
8. Disconnect hitch safety chain (#10) from the tractor.
9. Pull back on lock collar (#8) and pull driveline from tractor power take-off shaft.
10. Collapse driveline (#8) by pushing tractor end of driveline toward the cutter gearbox.
11. Store yoke end of driveline (#8) on the cutter. Do not store yoke end in the dirt.
12. Adjust park jack (#11) up until hitch weight is removed from tractor drawbar.
13. Remove hex nut (#7), lock washer (#6), flat washers (#4 & #5) and bolt (#3) from clevis hitch (#2).
14. Start tractor and drive slowly forward several feet while watching to make sure no components are still hooked to the tractor.
15. Shut tractor down before dismantling. Refer to “**Tractor Shutdown Procedure**” on page 35.
16. Install bolt (#3), flat washers (#4 & #5), lock washer (#6), and hex nut (#7) in clevis hitch (#2) for safe keeping.

## Section 4: Operating Instructions

### General Operating Instructions

It is important that you familiarize yourself with the Operator's Manual, completed Operator's Checklist, properly attached cutter to your tractor, made leveling adjustments, and preset your cutting height before beginning a running operational safety check on your Land Pride Rotary Cutter.

The running operational safety check may now be done. It is important that at any time during this safety check you detect a malfunction in either the cutter or tractor that you immediately shut the tractor off, remove its key, and make necessary repairs and/or adjustments before continuing on.

Make sure, before starting the tractor, that the park brake is engaged, power take-off is disengaged, and cutter is resting on the ground. Start tractor and set engine throttle speed at a low idle. Raise cutter with tractor's rear hydraulic lift control lever to transport position making sure that the driveline does not bind and does not contact the cutter frame. Lower cutter to the ground and at a low engine speed engage the power take-off. If everything is running smoothly at a low idle, slowly raise cutter to cutting height checking for bind or chatter in the driveline. Lower the cutter to the ground and increase the tractor's engine rpm until it reaches the cutter full power take-off operating speed of 540 rpm. If everything is still running smoothly, once more raise the cutter to cutting height to check for driveline bind or chatter. Lower the cutter to the ground, return engine to a low idle, and disengage power take-off. Position adjustable stops on the tractor's hydraulic lift lever or the Pull-Type hydraulic cylinder rod so the cutter can be consistently returned to the same cutting and transport height.

You should now be ready to transport to your cutting site at a safe ground speed. On roadways, transport in such a manner that faster moving vehicles can easily see you and pass you safely. Reduce your speed when traveling over rough and hilly terrain. Avoid quick or sharp steering corrections. Take extra care to ensure that the mower doesn't come into contact with obstacles such as trees, buildings, or fences. Use accessory lights and appropriate reflective devices to provide adequate warning to pedestrians and other vehicle operators when traveling on public roads and in the dark of night. Comply with all local, state, and federal laws.

It is important that you inspect the area where you will be cutting and clear it of safety hazards and foreign objects either before or after you arrive at the cutting site. Never assume the area is clear. Cut only in areas you are familiar with and are free of debris and unseen objects. Extremely tall grass should be cut twice to detect potential hazards. In the event you do strike an object stop the cutter and tractor immediately to inspect and make necessary repairs to the cutter before resuming operation. It really pays to inspect a new area and to develop a safe plan before cutting.

You will need to maintain 540 rpm power take-off speed and 2 to 5 mph ground speed to produce a clean cut. Make a tractor gear and range selection that will enable you to maintain these speed combinations. Generally the quality of cut is better at lower ground speeds. Dense ground cover will create the need to slow down even more. Never travel fast enough to overload tractor or cutter. Ground speed depends on density of material being cut and size of attached tractor.

In certain conditions tractor tires will roll grass down resulting in an uneven cut when the grass fails to rebound. Should this happen you may try reversing the direction of cut and/or double cut to achieve the desired finish. Avoid very low cutting heights especially on extremely uneven terrain. Always cut downward on slopes and avoid crossing the face of steep slopes. Avoid sharp drops and cross diagonally through dips to prevent hanging up the tractor and cutter. Slow down in turns. Remember to look back often.

Now that you're prepared and well briefed you may begin cutting. Begin cutting by doing the following:

- Reducing the tractor's engine rpm
- Make sure the cutter is on the ground in cutting position
- Engage the power take-off
- Raise the engine rpm to the appropriate power take-off speed
- Begin cutting.

Make wide turns when possible. Use 3-point hitch and optional Quick Hitch models to lift unit when making tight turns and backing-up. Try increasing or decreasing ground speed to determine effect on quality of cut. After the first 50 feet, stop and check to see that the cutter is adjusted properly. With a little practice you will be pleased with what your Land Pride Rotary Cutter can do.

When you are done mowing, need to take a break, or just need to make a few adjustments to the cutter, remember to always do the following:

- Reduce the tractor's engine rpm
- Disengage the power take-off
- Stop on level ground
- Set the park brake
- Turn off the engine and remove the key
- Stay on the tractor until the cutter blades have come to a complete dead stop.

See "**Specifications & Capacities**" and "**Features & Benefits**" for additional information and performance enhancing options.



## Section 5: Maintenance & Lubrication

### Maintenance

Proper servicing and adjustments are key to the long life of any implement. With careful inspection and routine maintenance, you can avoid costly downtime and repair.

Check all bolts and pins after using the unit for several hours and on a regular basis thereafter to ensure they are tight and secured. Replace worn, damaged or illegible safety labels by obtaining new labels from your Land Pride Dealer.

#### **DANGER**

To avoid serious injury or death:

- Perform maintenance only on a cutter that is not running. Disengage power take-off, place tractor in park or set park brake, shut tractor engine off, remove switch key, and wait for blades to come to a complete stop before dismounting tractor to perform maintenance.
- Always disconnect driveline from power take-off shaft before servicing underside of cutter. The tractor can be started with power take-off engaged.
- Always secure equipment with solid, non-concrete supports before working under it. Never go under equipment supported by concrete blocks or hydraulics. Concrete can break, hydraulic lines can burst, and/or hydraulic controls can be actuated even when power to hydraulics is off.

#### **WARNING**

To avoid serious injury or death:

- Perform scheduled maintenance. Check for loose hardware, missing parts, broken parts, structural cracks, and excessive wear. Make repairs before putting the implement back into service.
- Do not alter implement or replace parts on the implement with other brands. Other brands may not fit properly or meet OEM (Original Equipment Manufacturer) specifications. They can weaken the integrity and impair the safety, function, performance, and life of the implement. Replace parts only with genuine OEM parts.
- Buildup of debris around moving components and gearboxes is a fire hazard. Keep rotating parts and gearboxes free from debris to avoid serious injury and property damage.
- Improper oil level can cause bearing failure and be a fire hazard. Maintain proper gearbox oil level to avoid serious injury and property damage.

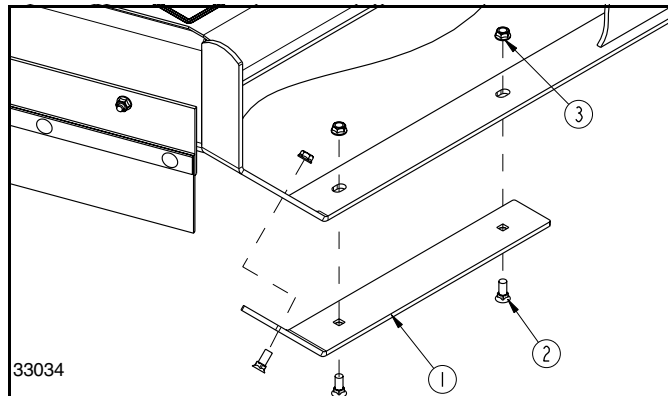

**Land Pride Skid Shoe Replacement Parts**

Item	Part No.	Part Description
1	326-479D	SKID SHOE
2	802-603C	PLOW 3/8" - 16 x 1" GR5
3	803-198C	NUT HEX WHIZ 3/8-16 PLT

**Skid Shoe Replacement**  
Figure 5-1

### Skid Shoes

Refer to Figure 5-1:

**326-120A Skid Shoe Kit**  
(Includes 2 skid shoes & mounting hardware)

#### **WARNING**

To avoid serious injury or death:

Excessive wear on skid shoes can damage side panels, cause inadequate operation of cutter, and create a safety hazard. Always replace skid shoes at the first sign of wearing thin.

There are skid shoes mounted on the cutter sides. Check both skid shoes for wear and replace if necessary. Order only genuine Land Pride parts from your local Land Pride dealer.

1. Remove 3/8" hex whiz nuts (#3), 3/8" plow bolts (#2), and skid shoe (#1) as shown.
2. Plow bolts should be checked for wear and replaced when worn.
3. Attach new skid shoe (#1) to cutter with existing 3/8" plow bolts (#2), and secure with 3/8" hex whiz nuts. Tighten to the correct torque.
4. Repeat on opposite side.

## Cutter Blade Maintenance

### WARNING

To avoid serious injury or death:

- Do not operate cutter with blades that are out-of-balance, bent, excessively worn, excessively nicked, or with blade bolts that are excessively worn. Such blades can break loose at high speeds.
- Do not attempt to straighten a bent blade or weld on a blade. Do not attempt to modify a blade such as hard surfacing, heat treating, cold treating, or by any other method. Always replace blades with new Land Pride blades to assure safety.
- A locknut that has been removed can lose its thread locking properties. Reusing a used locknut can result in a thrown blade. Always use a new locknut when installing blades.

**IMPORTANT:** Only replace cutting blades in pairs with genuine OEM blades. Replacing single blades can result in an out-of-balance condition that will contribute to premature bearing wear/breakage and/or structural cracks in gearbox and/or deck.

Always inspect cutting blades before each use. Make certain they are properly installed and are in good working condition. Replace any blade that is damaged, worn, bent, or excessively nicked. Small nicks can be ground out.

Remove blades and sharpen or replace as follows:

1. Place tractor gear selector in park, set brakes, shut engine off, and remove ignition key.
2. Disconnect front driveline from tractor power take-off and secure cutter deck in the up position with solid supports before servicing underside of cutter.
3. Inspect cutting blades. Make certain they are properly installed and are in good working condition. Replace any blade that is damaged, worn, bent, or excessively nicked. Small nicks can be ground out.

**Refer to Figure 5-2:**

4. To remove blades from the cutter, remove access cover (#5).
5. Rotate blade bolt (#1) until aligned with access hole (A).
6. Unscrew locknut (#3) to remove cutting blade (#6). Blade bolt (#1) is keyed and will not turn freely.
7. Repeat steps 5 & 6 for the other blade.
8. Both blades should be sharpened at the same angle as the original cutting edge and must be replaced or re-ground at the same time to maintain proper balance in the cutting unit. The following precautions should be taken when sharpening blades:
  - a. Do not remove more material than necessary.
  - b. Do not heat and pound out a cutting edge.
  - c. Do not grind blades to a razor edge. Leave a blunt cutting edge approximately 1/16" thick.

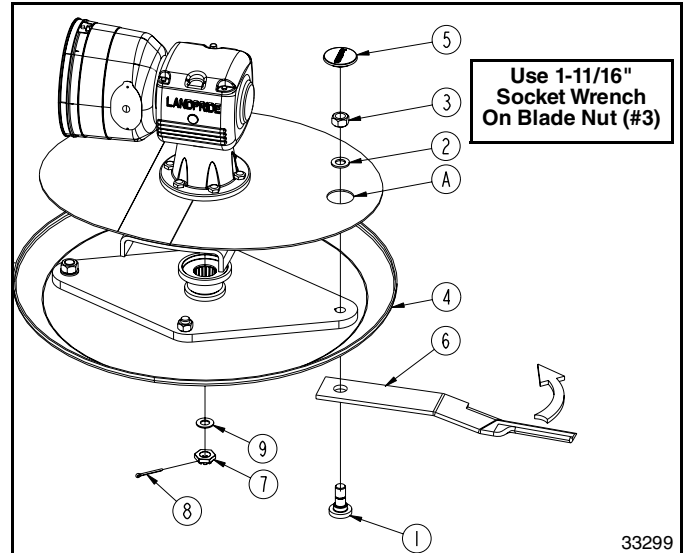

**Land Pride Cutter Blade Parts**

Item	Part No.	Part Description
	318-586A	BLADE BOLT KIT (items 1, 2, & 3 below)
1	802-277C	BLADE BOLT 1 1/8-12 x 3 7/16 WITH KEY
2	804-147C	WASHER FLAT 1 HARD ASTM F436
3	803-170C	NUT HEX TOP LOCK 1 1/8-12 PLATE
4	318-482D	DISHPAN
5	840-273C	PLUG LP 3" ID RUBBER
6	820-168C	STANDARD BLADE 1/2" x 4" x 29" LG. CCW

**Cutter Blade Assembly (Counterclockwise Rotation)**  
Figure 5-2

- d. Always grind cutting edge so end of blade remains square to cutting edge and not rounded.
  - e. Do not sharpen back side of blade.
  - f. Both blades should weigh the same with not more than 1 1/2 oz. difference. Unbalanced blades will cause excessive vibration which can damage gearbox bearings and create structural cracks.
9. Carefully check cutting edges of blades in relation to blade carrier rotation to ensure correct blade placement. Blade rotation is counterclockwise with cutting edge leading. Airfoil (lift) must be oriented towards the top of the deck.

**IMPORTANT:** Examine blade bolts (#1) and flat washers (#2) for excessive wear and replace if worn.

10. Insert blade bolt (#1) through blade (#6), dishpan (#4), and flat washer (#2). Secure blade with a **new locknut (#3)** and torque to 450 ft-lb.
11. Repeat step 10 for the other blade.
12. Replace access cover (#5).
13. If replacing dishpan (#4), nut (#7) on gearbox output shaft should be torqued to 450 ft-lbs. minimum and cotter pin (#8) installed with both legs bent opposite directions around the nut.

### Driveline Slip-Clutch

The drive-train is protected from shock loads with a four plate slip-clutch. The slip-clutch must be capable of slippage during operation. Always do a “Clutch Run-In” operation at the beginning of each season and after long periods of inactivity to remove any oxidation that may have accumulated on the friction surfaces. Repeat “Clutch Run-In” instructions below when moisture and/or condensation seizes the inner friction plates.

#### WARNING

To avoid serious injury or death:

Always follow “Tractor Shutdown Procedure” provided in this manual before dismantling the tractor.

### Clutch Run-In

Refer to Figure 5-3:

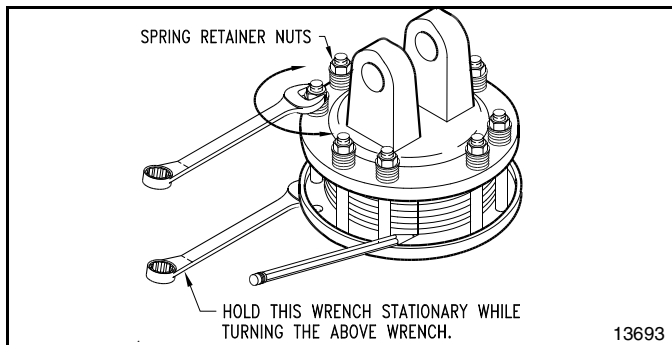

**Clutch**  
**Figure 5-3**

- Using a pencil or other marker, scribe a line across the exposed edges of the clutch plates and friction discs.
- Carefully loosen each of the 8 spring retainer nuts by exactly 2 revolutions. It will be necessary to hold hex end of retainer bolt in order to count the exact number of revolutions.
- Start tractor and engage power take-off drive for 2-3 seconds to permit slippage of the clutch surfaces. Disengage power take-off, then re-engage a second time for 2-3 seconds. Disengage power take-off, shut off tractor, and remove key. Wait for all components to stop before dismantling from tractor.
- Inspect clutch and ensure that the scribed markings made on the clutch plates have changed position. Slippage has not occurred if any two marks on the friction disc and plate are still aligned. A clutch that has not slipped must be disassembled to separate the friction disc plates. See “Clutch Assembly and Disassembly” on page 42.
- Tighten each of the 8 spring retainer nuts on the clutch housing exactly 2 revolutions to restore the clutch to the original setting pressure.
- The clutch should be checked during the first hour of cutting and periodically each week. An additional set of scribe marks can be added to check for slippage. See Figure 5-5 on page 43 to adjust spring length.

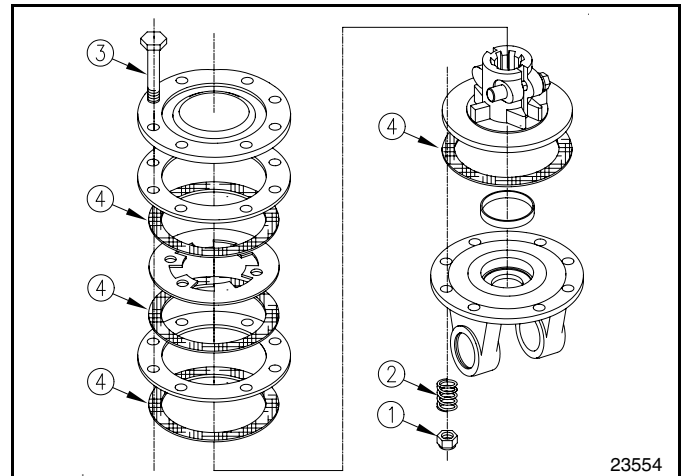

**Clutch Disassembly**  
**Figure 5-4**

### Clutch Assembly and Disassembly

#### Disassembly

Refer to Figure 5-4:

**IMPORTANT: Refer to Figure 5-5. Be Sure to measure and record length (“A”) of each clutch spring before disassembling the clutch.**

See “IMPORTANT NOTE” above before disassembling clutch. After measuring and recording each spring length, remove spring retainer nuts (#1), springs (#2), and bolts (#3). Each friction disc (#4) must then be separated from the metal surface adjacent to it. Refer to the Parts Manual for a detailed parts breakdown.

#### Inspection

Inspect all parts for excessive wear and condition. Clean all parts that do not require replacement. The original friction disc thickness is 1/8" (3.2mm) and should be replaced if thickness falls below 3/64" (1.1mm). If clutches have been slipped to the point of “smoking”, the friction discs may be damaged and should be replaced. Heat build-up may also affect the yoke joints.

#### Assembly

Refer to Figure 5-5 on page 43:

Reassemble each friction disc (#4) next to the metal plate it was separated from. Install bolts (#3) through end plates and intermediate plates as shown. Place springs (#2) over bolts (#3) and secure with nuts (#1).

Refer to Figure 5-5 on page 43:

Progressively tighten each spring retainer bolt until correct spring height “A” dimension is obtained.

Section 5: Maintenance & Lubrication

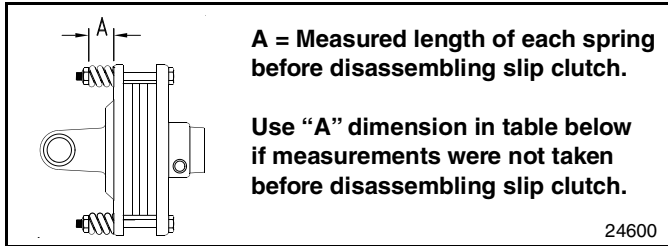

Hitch Type	Driveline No.	Power Take-Off Speed	Cat No.	A (inches) Spring Height
3-Point Pull-Type	826-652C 826-682C	540	5	1.11" to 1.12" (1 1/8")

Clutch Adjustment  
Figure 5-5

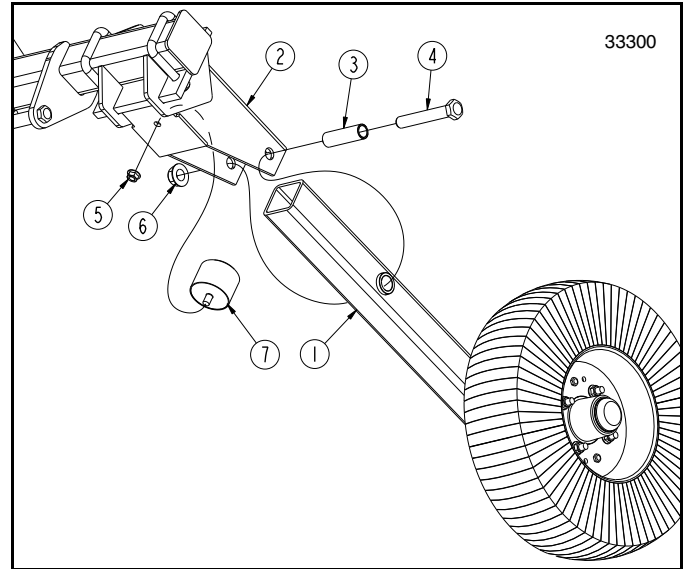

Pull-Type Sandwich Mount  
Figure 5-7

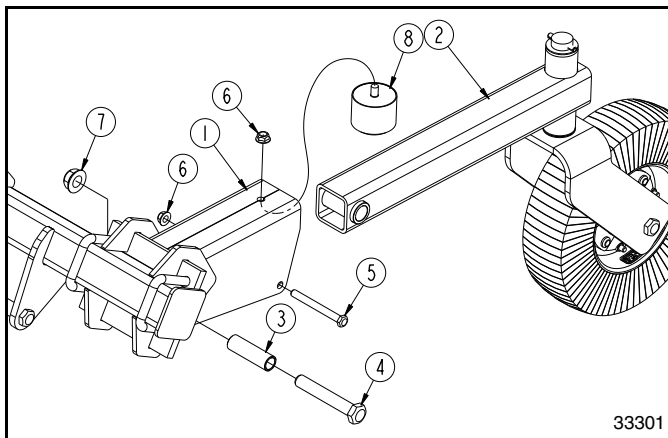

3-Point Sandwich Mount  
Figure 5-6

### 3-Point Sandwich Mount

Refer to Figure 5-6:

Replace sandwich mount (#8) when rubber becomes deteriorated and starts to break-up.

1. Remove bolts (#5 & #4) from lift mount (#1).
2. Remove tailwheel arm (#2) from lift mount (#1).
3. Unscrew nut (#6) and remove deteriorated sandwich mount (#8).
4. Install new sandwich mount (#8) and secure with 1/2"-13 hex flange locknut (#6). Tighten locknut to the correct torque.
5. Reinsert tailwheel arm (#2) in lift mount (#1) and secure with existing 7/8"-9 x 5 1/2" GR5 bolt (#4), pivot spacer bushing (#3), and flange locknut (#7). Tighten locknut to the correct torque.
6. Reinsert 1/2"-13 x 4 3/4" bolt (#5) and secure with hex flange locknut (#6). Tighten locknut to the correct torque.

### Pull-Type Wheel Cushion

Refer to Figure 5-7:

Replace sandwich mount (#7) when rubber becomes deteriorated and starts to break-up.

1. Remove bolt (#4) from lift mount (#2).
2. Remove tailwheel arm (#1) from lift mount (#2).
3. Unscrew nut (#6) and remove deteriorated sandwich mount (#7).
4. Install new sandwich mount (#7) and secure with 1/2"-13 hex flange locknut (#6). Tighten locknut to the correct torque.
5. Reinsert tailwheel arm (#1) in lift mount (#2) and secure with existing 7/8"-9 x 5 1/2" GR5 bolt (#4), pivot spacer bushing (#3), and flange locknut (#6). Tighten locknut to the correct torque.

Section 5: Maintenance & Lubrication

**Long-Term Storage**

Clean, inspect, service, and make necessary repairs to the implement when storing it for long periods and at the end of the season. This will help to ensure the unit is ready for field use the next time you hook-up to it.

 **DANGER**

To avoid serious injury or death:

- Always disconnect driveline from power take-off shaft before servicing drivetrain and cutter blades. The power take-off can be engaged if tractor is started.
- Always secure equipment with solid, non-concrete supports before working under it. Never go under equipment supported by concrete blocks or hydraulics. Concrete can break, hydraulic lines can burst, and/or hydraulic controls can be actuated even when power to hydraulics is off.

 **WARNING**

To avoid serious injury or death:

Always store cutter with 3-point hitch pivoted back as far as possible. The floating 3-point hitch when not hooked to a tractor can fall backwards unexpectedly causing bodily injury.

1. Clean off any dirt and grease that may have accumulated on the cutter and moving parts. Scrape off compacted dirt from the bottom of deck and then wash surface thoroughly with a garden hose. A coating of oil may also be applied to the lower deck area to minimize oxidation.
2. Check blades and blade bolts for wear and replace if necessary. See “**Cutter Blade Maintenance**” on page 41.
3. Inspect for loose, damaged or worn parts, and adjust or replace as needed.
4. Repaint parts where paint is worn or scratched to prevent rust. Ask your Land Pride dealer for aerosol touch-up paint. Paint is also available in touch-up bottles with brush, quarts, and gallon sizes by adding TU, QT, or GL to the end of the aerosol part number.

Land Pride Touch-up Paint	
Part No.	Part Description
821-011C	PAINT LP BEIGE SPRAY CAN
821-054C	PAINT MEDIUM RED SPRAY CAN
821-058C	PAINT GREEN SPRAY CAN
821-066C	PAINT ORANGE SPRAY CAN
821-070C	PAINT GP GLOSS BLACK SPRAY CAN

5. Replace all damaged or missing decals.
6. Lubricate as noted in “**Lubrication Points**” starting on page 46.
7. Store cutter on a level surface in a clean, dry place. Inside storage will reduce maintenance and make for a longer cutter life.
8. Follow all unhooking instructions on page 38 when disconnecting tractor from cutter.

**Ordering Replacement Parts**

Land Pride offers equipment in factory standard Beige with black highlights. This implement may also be purchased in Orange, Green, or Red.

When ordering an optional color, the suffix number corresponding to the color must be added at the end of the part number. Parts ordered without the suffix number will be supplied in factory standard colors.

- |                     |                    |
|---------------------|--------------------|
| 81 . . . . . Green  | 83 . . . . . Red   |
| 82 . . . . . Orange | 85 . . . . . Black |

For example, if you are ordering a replacement part with part number 555-555C and the existing part is orange, then add the suffix 82 to the end of the number to make the part number read 555-555C82.



Lubrication Points

<b>Lubrication Legend</b>	Multi-purpose spray lube	Multi-purpose grease lube	Multi-purpose oil lube	<b>50 Hrs</b> Intervals in hours at which lubrication is required

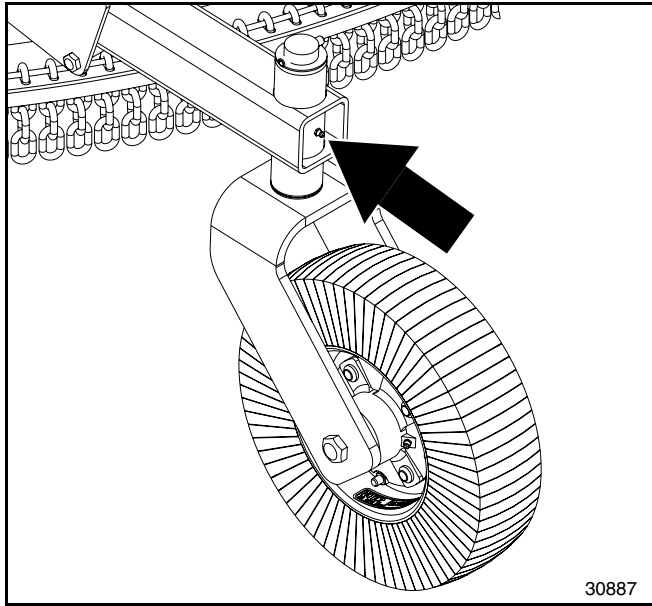

	<b>24 Hours</b>
--	-----------------

**Gauge Wheel Spindle Tube**

Type of Lubrication: Grease

Quantity = 6 pumps

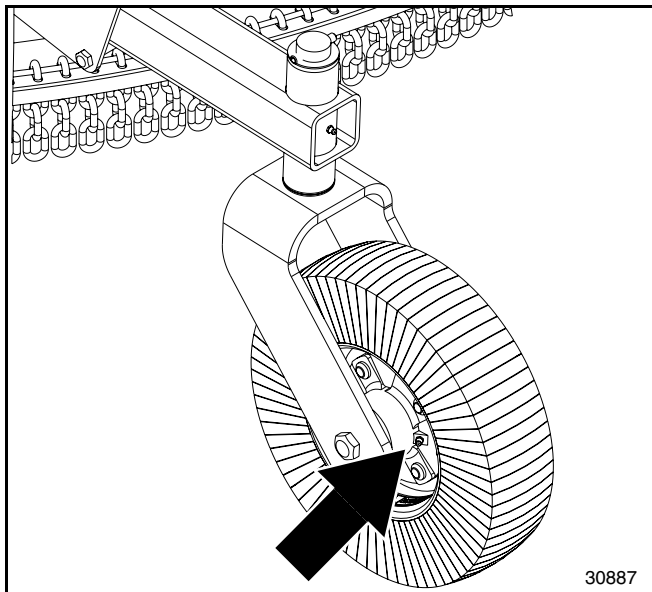

	<b>8 Hours</b>
--	----------------

**Gauge Wheel Hub**

Type of Lubrication: Multi-purpose Grease

Quantity = 2 pumps

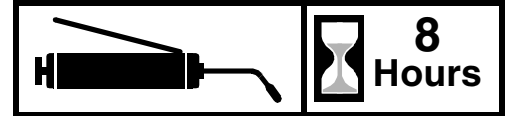
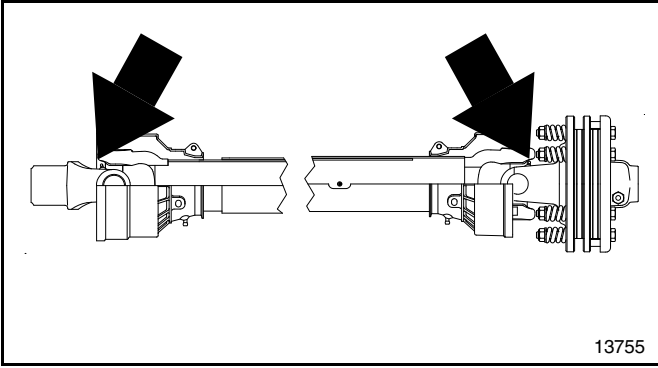

**Driveline U-joints**

Type of Lubrication: Grease  
Quantity = 6 pumps

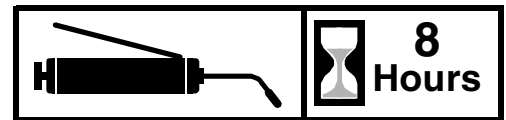
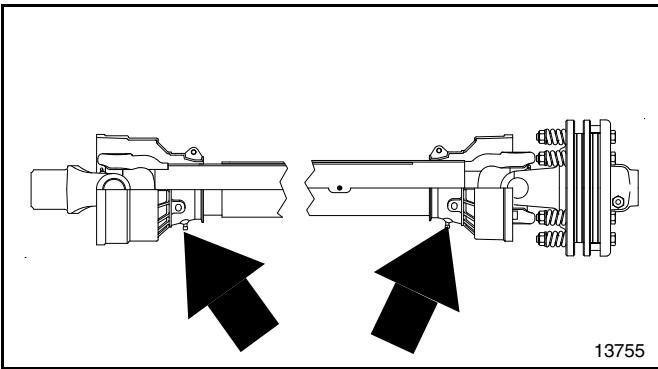

**Driveline Shield Bearings**

Type of Lubrication: Grease  
Quantity = 6 pumps

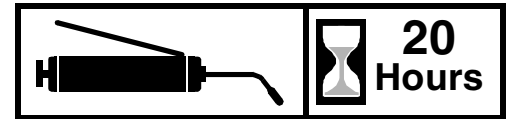
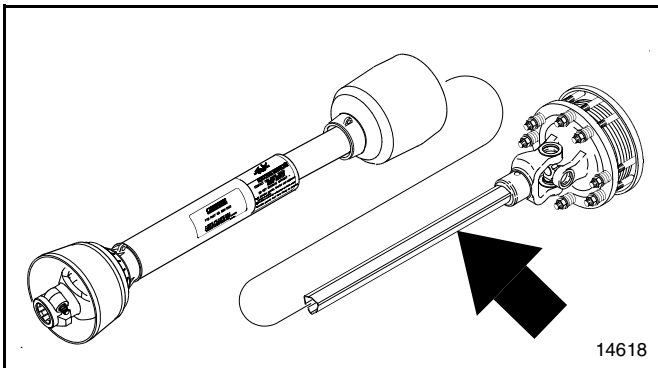

**Driveline Profiles**

Quantity = Clean & coat inner tube of driveline with a light film of grease and then reassemble.



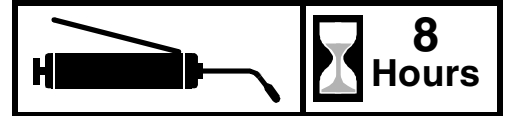
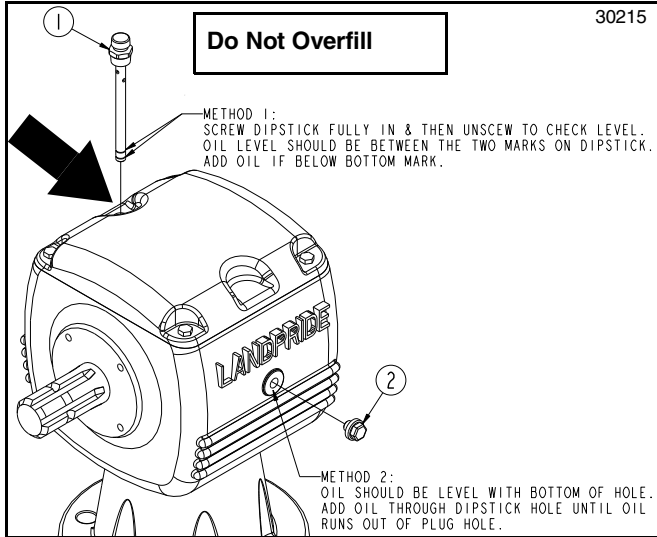

**Gearbox**

**NOTE:** Do not overfill! Cutter should be level when checking oil. Oil expands when hot, therefore, always check oil level when cold.

**Method 1:** Unscrew top vented dipstick (#1). Wipe oil from dipstick and screw dipstick in without tightening. Unscrew dipstick and check oil on dipstick. If below bottom level mark, add recommended gear lube through dipstick hole until oil reaches top mark on dipstick. Reinstall vented dipstick and tighten.

**Method 2:** Remove side oil plug (#2). If oil is below bottom of plug hole, add recommended gear lube through top dipstick hole until oil flows out of side plug hole. Reinstall and tighten side oil plug (#2) and vented dipstick (#1).

Type of Lubrication: 80-90W EP Gear Lube

Quantity = Fill until oil reaches top mark on dipstick or begins to flow out side plug hole in gearbox.

**IMPORTANT:** This implement is shipped with a vented dipstick packaged in the Operator's Manual bag and should have been installed in the gearbox by your dealer. Please consult your dealer if vented dipstick was not included.

**NOTE:** Use a suction or siphon pump to drain gearbox of oil when there is not an oil drain plug.

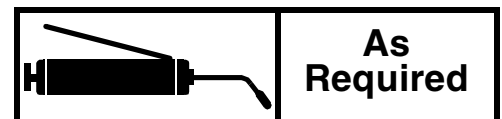
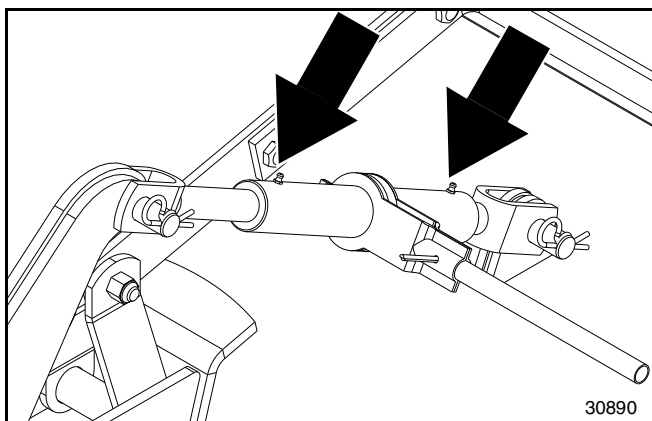

**Ratchet Jack (Optional)**

Type of Lubrication: Multi-purpose Grease

Quantity = Until grease purges from threads.



### RCF3684 Model

Specifications & Capacities		
Model Numbers	RCF3684 3-Point Type	RCF3684 Pull-Type
Machine weight	2,000 lbs (907.2 kg) With front & rear single chain guards	2,104 lbs (954.4 kg) With hydraulic adjustment and front & rear single chain guards
Hitch	Category II or III with floating clevis top link, Quick Hitch adaptable	Pull-type with clevis
Pull type tongue weight	N/A	894 lbs (405.5 kg)
Cutting width	84" (2.13 m)	
Overall width	90 1/2" (2.30 m)	
Overall length	130" (3.30 m)	179 1/2" (4.56 m)
Deck height (Bottom of deck to bottom of skid shoe)	13 3/8" (34.0 cm)	
Cutting height	2" - 12" (5.1 cm to 30.5 cm)	
Cutting capacity	4" (10.2 cm) Diameter	
Recommended tractor horsepower	70-190 hp (52.2-141.7 kw)	50-190 hp (37.3-141.7 kw)
Power take-off Speed	540 rpm	
Gearbox	1:1.21 Speed-up beveled gears, Cast iron housing, 1 3/4" (4.4 cm) - 20 spline input shaft and 2 3/8" (6.0 cm) output shaft	
Gearbox lubricant	80-90W oil	
Gearbox oil capacity	10 pints (4.73 L)	
Deck construction	All welded deck	
Deck material thickness	3/16" (5 mm)	
Side skirt material thickness	1/4" (6 mm)	
Skid construction	Replaceable bolt on skid shoes	
Stump jumper / blade holder	3/16" (5 mm) Round dish shaped bolt-on stump-jumper with diamond shaped blade bar	
Blades (2)	1/2" x 4" (1.3 cm x 10.2 cm) Heat treated alloy steel free-swinging high lift - low friction	
Blade bolts	Keyed with harden flat washers & locknuts	
Blade tip speed	14,369 fpm (73.0 mps)	
Driveline	ASAE category 5 with 4-plate slip clutch	
Driveline protection	4 plate slip clutch	
Transport axle	Cushioned shock absorption	
Rear deck height adjustment options	Ratchet jack or hydraulic cylinder	
Tailwheel	4" x 8" x 15" Laminated tire with cast iron hub	4" x 8" x 21" Laminated tire with cast iron hub
Front guard	Optional: Rubber belting, single chain guard or double chain guard	
Rear Guard	Optional: Single chain guard or double chain guard	
Jack Stand	Jack stand on tongue of pull-type cutter	

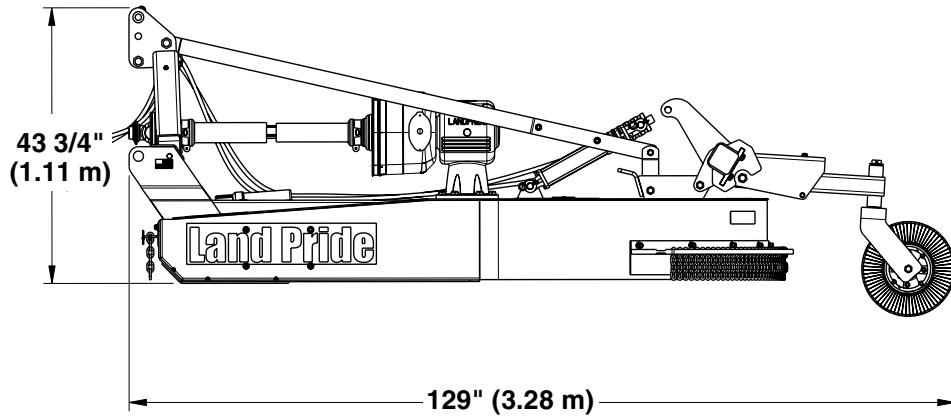
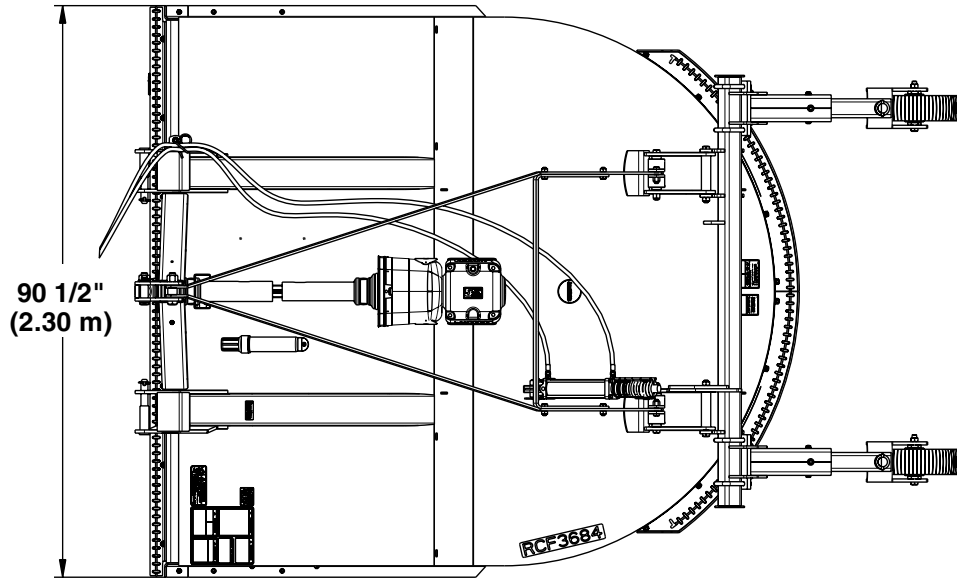

**3-Point Rotary Cutter**

30891

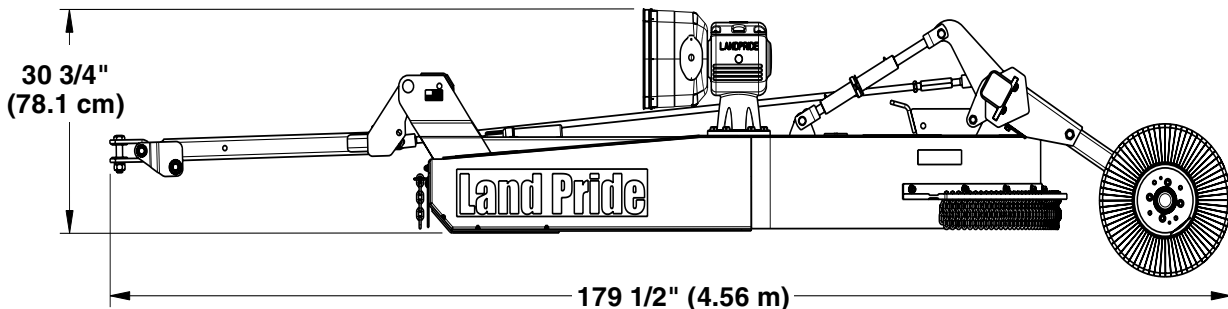

**Pull-Type Rotary Cutter**

30892



### RCF3684 Model

Features	Benefits
<b>Surpassed rugged industry standards</b>	All Land Pride Cutters have been designed and tested and meet rigorous voluntary testing procedures specified by ANSI.
<b>5 Year gearbox warranty</b>	A rugged heavy built gearbox capable of handling heavy cutting applications. Shows Land Pride's confidence in gearbox integrity.
<b>Cat. 5 driveline with 4-plate slip-clutch</b>	Slip-clutch driveline offers convenience for continual work.
<b>Cat. II and III 3-point hitch options with Quick Hitch capability</b>	Fits a wide variety of tractors. Quick Hitch provides for fast hook-up.
<b>Dual position clevis type 3-point floating top link</b>	Permits deck to follow the terrain for an even cut.
<b>Lower clevis type 3-point hitch</b>	Allows for ease of hook-up to tractor. Also adds additional strength allowing for an even pull from the tractor's lower arms, vs. pulling on a single pin design.
<b>Pull-type hitch option</b>	Fits older tractors without a top link and smaller tractors without enough lift capacity.
<b>84" Cutting width</b>	Wide cutting width, reduces cutting time in the field.
<b>Heavy deck construction with 3/16" deck top &amp; 1/4" side skirts</b>	Strong heavy deck material for rugged use. Heavy side panels protects sides from debris being thrown against them from the blades.
<b>Fully welded deck</b>	Adds additional strength and deck integrity.
<b>Round back design</b>	Helps discharge grass better than enclosed or partially enclosed cutters.
<b>13 3/8" Deck height</b>	Allows cutter to handle heavy cutting conditions.
<b>2" to 12" Cutting height</b>	Provides for a wide range of cutting conditions.
<b>High cutting capacity</b>	Can cut brushy areas with saplings up to 4".
<b>Skid shoes</b>	Provides sidewall reinforcement and protection to bottom of sidewall.
<b>1/2" x 4" Heat-treated free swinging blades</b>	Free swinging protects from obstructions. Heat-treated offers longer life.
<b>Splined blade bar hub</b>	Allows for tight positive fit of stump jumper and blade bar to gearbox output shaft.
<b>3/16" Plate stump jumper</b>	Standard round stump jumper slides over stumps, rocks, and debris.
<b>High blade tip speed</b>	Ensures clean cut.
<b>4" Dia. cutting capacity</b>	Can aid in clearing brush.
<b>Dual laminated tailwheels</b>	Dual tailwheels offer greater stability in uneven terrain. Laminated material is long lasting in rough conditions. Can't go flat.
<b>1 1/2" Heavy-duty spindle on tailwheel (3-point cutter)</b>	Tailwheels take a beating, spindle gives the strength to protect tailwheel assembly.
<b>Wheel bearings (Pull-type cutter)</b>	Tapered roller bearing in cast iron hub.
<b>Optional guarding</b>	Protect against flying debris.



## Troubleshooting Chart

Problem	Cause	Solution
<b>Oil seal leaking</b>	Gearbox overfilled	Drain to side plug hole
	Seals damaged	Replace seals
	Grass or wire wrapped on shaft in seal area	Check seal areas daily
<b>Driveline yoke or cross failing</b>	Clutch is froze	Slip clutches per “Run-In” instructions under “Driveline Slip-Clutch” on page 42.
	Shock load	Avoid hitting solid objects.
	Needs lubrication	Lubricate every 8 hours.
<b>Driveline clutch is slipping</b>	Power take-off engaged at high rpm	Slowly engage power take-off at low engine rpm
	Cutting too fast	Reduce travel speed
	Scalping the ground	Raise cutting height
	Cutting over solid objects	Avoid solid objects
	Clutch is not properly adjusted	Adjust clutch per instructions under “Driveline Slip-Clutch” on page 42.
	Clutch plates are worn out	Replace clutch plates.
	Foreign object in clutch plates	Remove foreign object from between clutch plates.
<b>Bent Driveline (NOTE: driveline should be repaired or replaced if bent)</b>	Contacting frame	Reduce lift height in transport position
	Contacting drawbar	Reposition drawbar
	Bottoming out	Shorten driveline
	Binding up	Not lubricating enough
<b>Driveline telescoping tube failing</b>	Shock load	Avoid hitting solid objects
<b>Driveline telescoping tube wearing</b>	Needs lubrication	Lubricate every 20 hours
<b>Blades Lock-up (Overlapped)</b>	Tractor power take-off has instant on	Engage power take-off at low rpm and then slowly increase engine speed.
	Tractor power take-off has Instant off	Slowly reduce engine speed to an idle & then disengage power take-off.
<b>Blades wearing excessively</b>	Cutting on sandy ground	Raise cutting height
	Contacting ground frequently	Raise cutting height
<b>Blades coming loose</b>	Blades not tightened properly	Tighten blade hardware. See “Cutter Blade Maintenance” on page 41
	Improper deck attitude	Lower front of deck, see page 30
<b>Blades breaking</b>	Hitting solid objects	Avoid hitting solid objects
<b>Blade carrier is loose</b>	Blade carrier hardware not tight	Tighten to specified torque
	Running loose in the past	Replace gearbox output shaft and blade carrier
<b>Blade bolt holes are worn</b>	Blade hardware running loose	Replace blades and blade bolts if worn
<b>Blade carrier is bent</b>	Hitting solid objects	Avoid hitting solid objects and replace blade carrier
<b>Excessive side skid wear</b>	Cutting height not level	Adjust cutter height
	Soil abrasive	Adjust cutter height
	Cutting too low	Adjust cutter height
<b>Excessive vibration</b>	Hitting solid objects	Inspect area before cutting. Do not hit solid objects.
	Driveline bent	Replace driveline
	Blade carrier bent	Replace blade carrier
	Blades loose	Tighten blade bolts
	Blade broken	Replace blade
	Blade will not swing	Remove and inspect blade
	Blades have unequal weight	Replace both blades
High torque start-up	Disassemble and inspect driveline for incorrectly located needles or damaged bearing cap.	
<b>Tailwheel support failing</b>	Lowering too fast	Adjust rate of drop
	Hitting objects when turning	Reduce speed on turns



Torque Values Chart for Common Bolt Sizes													
Bolt Size (inches)	Bolt Head Identification						Bolt Size (Metric)	Bolt Head Identification					
	Grade 2		Grade 5		Grade 8			Class 5.8		Class 8.8		Class 10.9	
in-tpi <sup>1</sup>	N · m <sup>2</sup>	ft-lb <sup>3</sup>	N · m	ft-lb	N · m	ft-lb	mm x pitch <sup>4</sup>	N · m	ft-lb	N · m	ft-lb	N · m	ft-lb
1/4" - 20	7.4	5.6	11	8	16	12	M 5 X 0.8	4	3	6	5	9	7
1/4" - 28	8.5	6	13	10	18	14	M 6 X 1	7	5	11	8	15	11
5/16" - 18	15	11	24	17	33	25	M 8 X 1.25	17	12	26	19	36	27
5/16" - 24	17	13	26	19	37	27	M 8 X 1	18	13	28	21	39	29
3/8" - 16	27	20	42	31	59	44	M10 X 1.5	33	24	52	39	72	53
3/8" - 24	31	22	47	35	67	49	M10 X 0.75	39	29	61	45	85	62
7/16" - 14	43	32	67	49	95	70	M12 X 1.75	58	42	91	67	125	93
7/16" - 20	49	36	75	55	105	78	M12 X 1.5	60	44	95	70	130	97
1/2" - 13	66	49	105	76	145	105	M12 X 1	90	66	105	77	145	105
1/2" - 20	75	55	115	85	165	120	M14 X 2	92	68	145	105	200	150
9/16" - 12	95	70	150	110	210	155	M14 X 1.5	99	73	155	115	215	160
9/16" - 18	105	79	165	120	235	170	M16 X 2	145	105	225	165	315	230
5/8" - 11	130	97	205	150	285	210	M16 X 1.5	155	115	240	180	335	245
5/8" - 18	150	110	230	170	325	240	M18 X 2.5	195	145	310	230	405	300
3/4" - 10	235	170	360	265	510	375	M18 X 1.5	220	165	350	260	485	355
3/4" - 16	260	190	405	295	570	420	M20 X 2.5	280	205	440	325	610	450
7/8" - 9	225	165	585	430	820	605	M20 X 1.5	310	230	650	480	900	665
7/8" - 14	250	185	640	475	905	670	M24 X 3	480	355	760	560	1050	780
1" - 8	340	250	875	645	1230	910	M24 X 2	525	390	830	610	1150	845
1" - 12	370	275	955	705	1350	995	M30 X 3.5	960	705	1510	1120	2100	1550
1-1/8" - 7	480	355	1080	795	1750	1290	M30 X 2	1060	785	1680	1240	2320	1710
1-1/8" - 12	540	395	1210	890	1960	1440	M36 X 3.5	1730	1270	2650	1950	3660	2700
1-1/4" - 7	680	500	1520	1120	2460	1820	M36 X 2	1880	1380	2960	2190	4100	3220
1-1/4" - 12	750	555	1680	1240	2730	2010	<sup>1</sup> in-tpi = nominal thread diameter in inches-threads per inch <sup>2</sup> N · m = newton-meters <sup>3</sup> ft-lb= foot pounds <sup>4</sup> mm x pitch = nominal thread diameter in millimeters x thread pitch						
1-3/8" - 6	890	655	1990	1470	3230	2380							
1-3/8" - 12	1010	745	2270	1670	3680	2710							
1-1/2" - 6	1180	870	2640	1950	4290	3160							
1-1/2" - 12	1330	980	2970	2190	4820	3560							
Torque tolerance + 0%, -15% of torquing values. Unless otherwise specified use torque values listed above.													
Additional Torque Values													
Blade Bolt Lock Nut							450 ft-lbs						
Blade Carrier Hub Nut							450 ft-lbs Minimum						



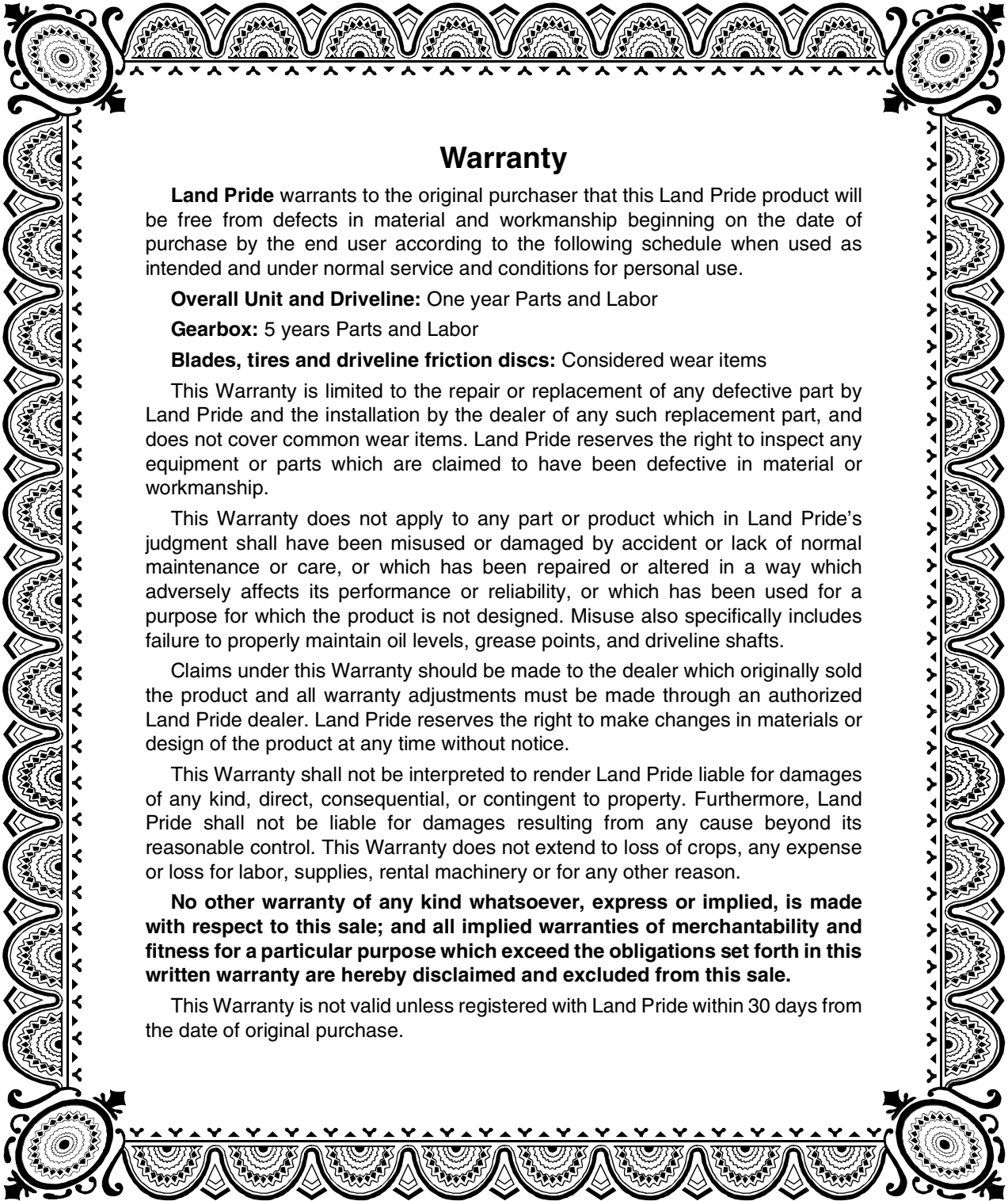

## Warranty

**Land Pride** warrants to the original purchaser that this Land Pride product will be free from defects in material and workmanship beginning on the date of purchase by the end user according to the following schedule when used as intended and under normal service and conditions for personal use.

**Overall Unit and Driveline:** One year Parts and Labor

**Gearbox:** 5 years Parts and Labor

**Blades, tires and driveline friction discs:** Considered wear items

This Warranty is limited to the repair or replacement of any defective part by Land Pride and the installation by the dealer of any such replacement part, and does not cover common wear items. Land Pride reserves the right to inspect any equipment or parts which are claimed to have been defective in material or workmanship.

This Warranty does not apply to any part or product which in Land Pride's judgment shall have been misused or damaged by accident or lack of normal maintenance or care, or which has been repaired or altered in a way which adversely affects its performance or reliability, or which has been used for a purpose for which the product is not designed. Misuse also specifically includes failure to properly maintain oil levels, grease points, and driveline shafts.

Claims under this Warranty should be made to the dealer which originally sold the product and all warranty adjustments must be made through an authorized Land Pride dealer. Land Pride reserves the right to make changes in materials or design of the product at any time without notice.

This Warranty shall not be interpreted to render Land Pride liable for damages of any kind, direct, consequential, or contingent to property. Furthermore, Land Pride shall not be liable for damages resulting from any cause beyond its reasonable control. This Warranty does not extend to loss of crops, any expense or loss for labor, supplies, rental machinery or for any other reason.

**No other warranty of any kind whatsoever, express or implied, is made with respect to this sale; and all implied warranties of merchantability and fitness for a particular purpose which exceed the obligations set forth in this written warranty are hereby disclaimed and excluded from this sale.**

This Warranty is not valid unless registered with Land Pride within 30 days from the date of original purchase.

**IMPORTANT:** The Online Warranty Registration should be completed by the dealer at the time of purchase. This information is necessary to provide you with quality customer service.

**Model Number** \_\_\_\_\_

**Serial Number** \_\_\_\_\_



Corporate Office: P.O. Box 5060  
Salina, Kansas 67402-5060 USA  
[www.landpride.com](http://www.landpride.com)

---