

RCR1884 Model

Specifications & Capacities	
Machine Weight with Front Rubber Guard and Rear Metal Band)	851 lbs. without driveline
Hitch	Category I or Category II, Quick-Hitch Ready
Cutting Width	84"
Overall Width	89"
Overall Length with Tail Wheel	135 1/8"
Deck Height (Bottom of Deck to Bottom of Skid Shoe)	9 1/8"
Cutting Height	2" - 11"
Cutting Capacity	2" Diameter
Recommended Tractor Horsepower	45 - 90 horsepower
Power Take-Off Speed	540 rpm
Gearbox Horsepower Rating	90 horsepower
Gearbox	1:1.44 Speed-Up Beveled Gears with Cast Iron Housing
Gearbox Lubrication Capacity & Type	7 Pints of 80-90W EP Gear Lube
Gearbox Input/ Output Shaft Size	Input Shaft = 1 3/8" - 6 Spline Output Shaft = 2" Dia.
Deck Construction	All welded deck
Deck Material Thickness	10 Ga.
Skid Construction	Standard 1/4" x 2 1/2" welded on
Stump Jumper	Oval 10 ga. Pan
Blades (2)	1/2" x 4" Heat Treated Alloy Steel Free-Swinging High Lift - Low Friction
Blade Bolt	Keyed with harden flat washer and locknut
Blade Tip Speed	17,113 fpm
Driveline	ASAE Category 4
Driveline Protection	Slip Clutch
Tailwheel Mount Assembly	Welded arm and Caster Fork
Tailwheel	4" x 8" x 15" Laminated Tire
Front Guard	Optional: Rubber Guard or Chain Guard
Rear Guard	Standard: Metal Band Optional: Chain Guard

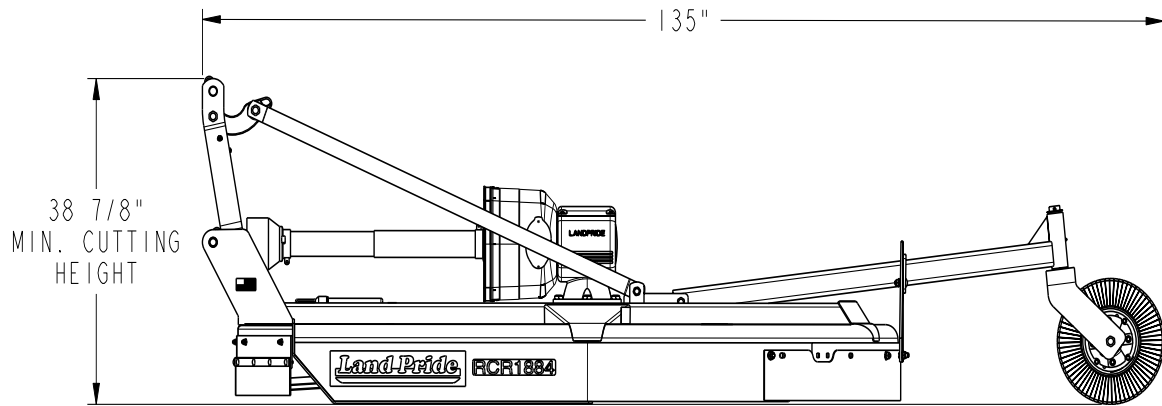
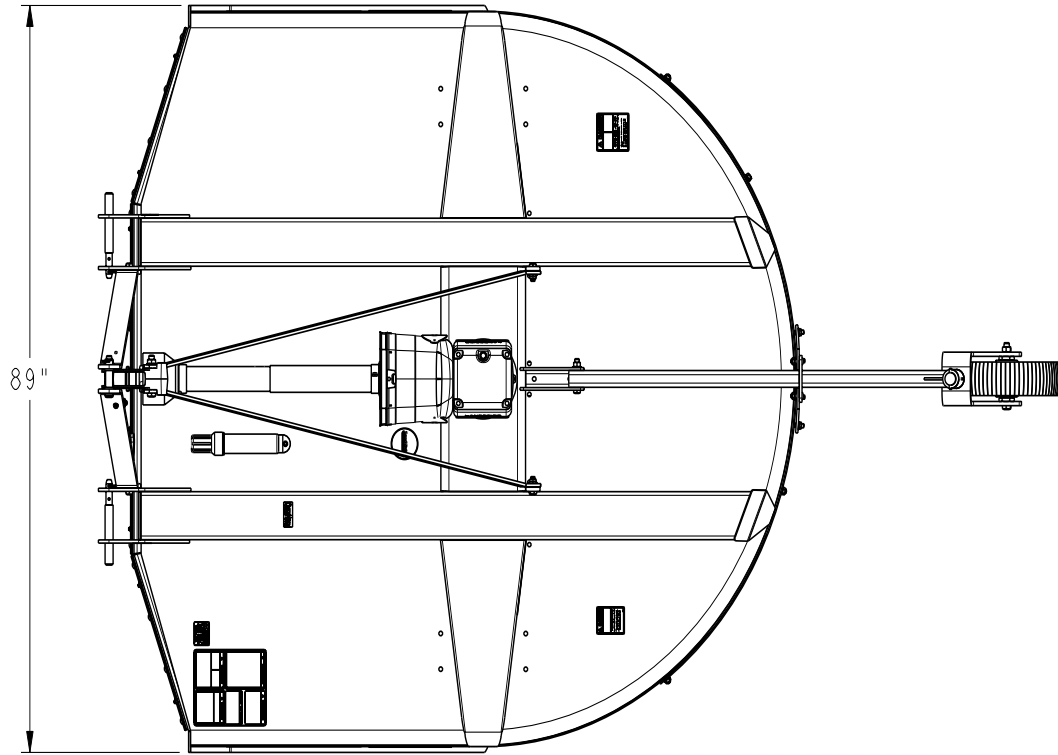

27738