

Assembly Instructions

**Rotary Cutters
Check Chain Kit**



When you see this symbol, the subsequent instructions and warnings are serious - follow without exception. Your life and the lives of others depend on it!

Before You Start

These option assembly instructions contain only information on assembling the attachment to the listed Rotary Cutters. A detailed Operator's Manual was supplied with the cutter when it was purchased. For more specific information on safety concerns refer to the Operator's Manual. Also included in the Operator's Manual is important information on operation, adjustment, troubleshooting, and maintenance for this attachment (some of these sections do not apply to all options).

A separate Parts Manual for replacement parts can be purchased from your dealer or download free of charge from our website at www.landpride.com. Have model and serial numbers handy when placing an order.

General Information

These option assembly instructions apply to the Check Chain option listed below:

312-071A CHECK CHAIN ASSY

This kit is designed to adapt to the following Land Pride products:

- RC25 RCR26
- RC35
- RCR25
- RCR35

Starting on page 2 is a detailed listing of parts included in these kits. Use this list as a checklist to inventory parts received.

Assembly Instructions

Check Chain Assembly

Refer to Figure 1:

Install check chain to cutter deck with 3/4" bolt 3/4" lockwasher and 3/4" nut.

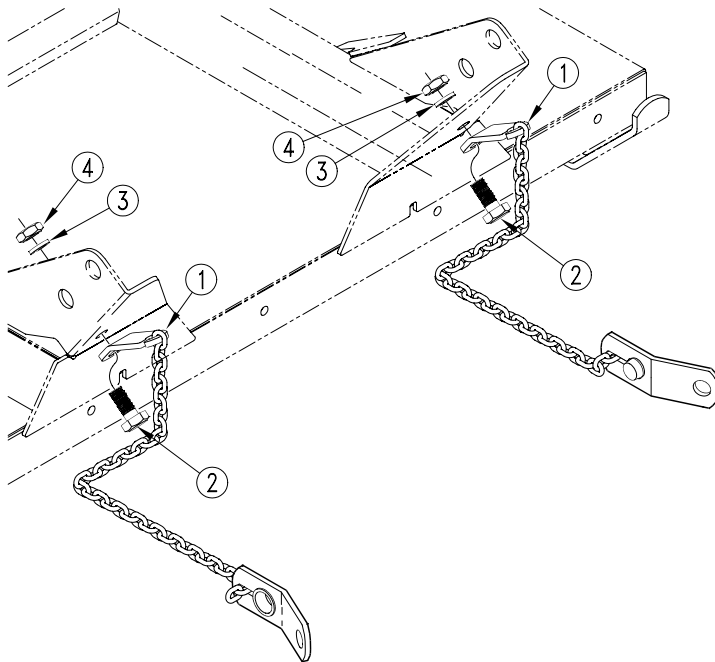

15794

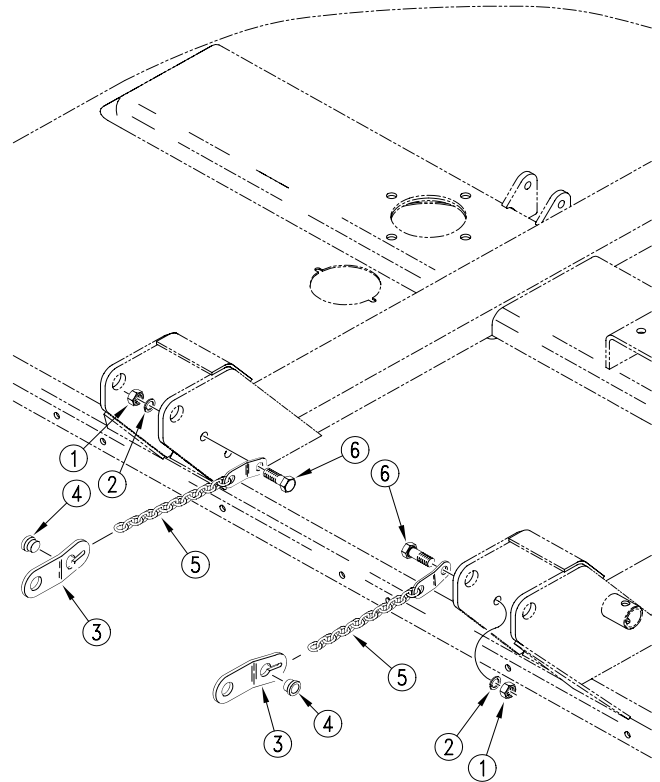

15984

**Check Chain Assembly
Figure 1**

Listing of Parts

312-071A CHECK CHAIN ASSY*Your Kit Includes:*

Qty.	Part No.	Part Description
2	312-062H	CHECK CHAIN WLDMT
2	327-397D	CHECK CHAIN MNT - TRACTOR
2	802-184C	HHCS 3/4-10X1 1/2 GR5
2	803-027C	NUT HEX 3/4-10 PLT
2	804-023C	WASHER LOCK SPRING 3/4 PLT
2	837-027C	CAP PLUG, POLY



Corporate Office: P.O. Box 5060
Salina, Kansas 67402-5060 USA

www.landpride.com