



- U.S.A. : **KUBOTA TRACTOR CORPORATION**
3401 Del Amo Blvd., Torrance, CA 90503, U.S.A.
Telephone : (310)370-3370
- Western Division : 1175 S. Guild Av., Lodi, CA 95240
Telephone : (209)334-9910
- Central Division : 14855 FAA Blvd., Fort Worth, TX 76155
Telephone : (817)571-0900
- Northern Division : 6300 at One Kubota Way, Groveport, OH 43125
Telephone : (614)835-1100
- Southeast Division : 1025 Northbrook Parkway, Suwanee, GA 30024
Telephone : (770)995-8855
- Canada : **KUBOTA CANADA LTD.**
5900 14th Avenue, Markham, Ontario, L3S 4K4, Canada
Telephone : (905)294-7477
- France : **KUBOTA EUROPE S.A.S**
19-25, Rue Jules Vercey, Z.I. BP88, 95101 Argenteuil Cedex, France
Telephone : (33)1-3426-3434
- Italy : **KUBOTA EUROPE S.A.S Italy Branch**
Via Grandi, 29 20068 Peschiera Borrome (MI) Italy
Telephone : (39)02-51650377
- Germany : **KUBOTA (DEUTSCHLAND) GmbH**
Senefelder Str. 3-5 63110 Rodgau /Nieder-Roden, Germany
Telephone : (49)6106-873-0
- U.K. : **KUBOTA (U.K.) LTD.**
Dormer Road, Thame, Oxfordshire, OX9 3UN, U.K.
Telephone : (44)1844-214500
- Spain : **KUBOTA ESPAÑA S.A.**
Avenida Recomba No.5, Poligno Industrial la Laguna, Leganes, 28914 (Madrid) Spain
Telephone : (34)91-508-6442
- Australia : **KUBOTA TRACTOR AUSTRALIA PTY LTD.**
25-29 Permas Way, Truganina, VIC 3029, Australia
Telephone : (61)-3-9394-4400
- Malaysia : **SIME KUBOTA SDN. BHD.**
No.3 Jalan Sepadu 25/123 Taman Perindustrian Axis,
Seksyen 25, 40400 Shah Alam, Selangor Darul Ehsan Malaysia
Telephone : (60)3-736-1388
- Philippines : **KUBOTA PHILIPPINES, INC.**
155 Panay Avenue, South Triangle Homes, 1103 Quezon City, Philippines
Telephone : (63)2-9201071
- Taiwan : **SHIN TAIWAN AGRICULTURAL MACHINERY CO., LTD.**
16, Fengping 2nd Rd, Talliao Shiang Kaohsiung 83107, Taiwan R.O.C.
Telephone : (886)7-702-2333
- Indonesia : **P.T. KUBOTA INDONESIA**
JALAN. Setyabudi 279, Semarang, Indonesia
Telephone : (62)-24-7472849
- Thailand : **SIAM KUBOTA CORPORATION CO., LTD.**
101/19-24 Moo 20, Navanakorn Industrial Estate, Tambon Khlongnueng, Amphur Khlongluang,
Pathumthani 12120, THAILAND
Telephone : (66)2-909-0300
- Korea : **KUBOTA KOREA CO., LTD.**
106-24 Mongsan-Ri, Mankyung-Up, Kimje-City, Chonrapuk-Do, KOREA
Telephone : (82)-63-544-5822
- India : **KUBOTA AGRICULTURAL MACHINERY INDIA PVT. LTD.**
Regus, Level 2 Altius, Olympia Tech Park, No.1 SIDCO Industrial Estate, Guindy, Chennai 600032, TN, India
Telephone : (91)-44-4299-4237
- Vietnam : **KUBOTA VIETNAM CO., LTD.**
Lot B-3A2-CN, My Phuoc 3 Industrial Park, Ben Cat District, Binh Duong Province, Vietnam
Telephone : (84)-650-3577-507

KUBOTA Corporation

English (Australia)
Code No. 3C473-9971-2

M
8
5
4
0
N

OPERATOR'S MANUAL

KUBOTA TRACTOR

MODEL M8540 NARROW



1AGAIHXAP001A

ABBREVIATION LIST

Abbreviations	Definitions
2WD	Two Wheel Drive
4WD	Four Wheel Drive
API	American Petroleum Institute
ASABE	American Society of Agricultural and Biological Engineers, USA
ASTM	American Society for Testing and Materials, USA
DIN	Deutsches Institut für Normung, GERMANY
DT	Dual Traction [4WD]
fpm	Feet Per Minute
GST	Glide Shift Transmission
Hi-Lo	High Speed-Low Speed
HST	Hydrostatic Transmission
m/s	Meters Per Second
PTO	Power Take Off
RH/LH	Right-hand and left-hand sides are determined by facing in the direction of forward travel
ROPS	Roll-Over Protective Structures
rpm	Revolutions Per Minute
r/s	Revolutions Per Second
SAE	Society of Automotive Engineers, USA
SMV	Slow Moving Vehicle

KUBOTA Corporation is ...

Since its inception in 1890, KUBOTA Corporation has grown to rank as one of the major firms in Japan.

To achieve this status, the company has through the years diversified the range of its products and services to a remarkable extent. Nineteen plants and 16,000 employees produce over 1,000 different items, large and small.









All these products and all the services which accompany them, however, are unified by one central commitment. KUBOTA makes products which, taken on a national scale, are basic necessities. Products which are indispensable. Products which are intended to help individuals and nations fulfill the potential inherent in their environment. KUBOTA is the Basic Necessities Giant.

This potential includes water supply, food from the soil and from the sea, industrial development, architecture and construction, and transportation.

Thousands of people depend on KUBOTA's know-how, technology, experience and customer service. You too can depend on KUBOTA.

UNIVERSAL SYMBOLS

As a guide to the operation of your tractor, various universal symbols have been utilized on the instruments and controls. The symbols are shown below with an indication of their meaning.

	Safety Alert Symbol		3-Point Lowering Speed Control
	Diesel Fuel		Remote Cylinder-Retract
	Fuel-Level		Remote Cylinder-Extend
	Engine-Rotational Speed		Hazard Warning Lights
	Hourmeter/Elapsed Operating Hours		Headlight-Low Beam
	Engine Coolant-Temperature		Headlight-High Beam
	Diesel Preheat/Glow Plugs(Low Temperature Start Aid)		Four-Wheel Drive-On
	Parking Brake		Four-Wheel Drive-Off
	Engine Intake/Combustion Air-Filter		Front-Wheel Drive-On
	Battery Charging Condition		Fast
	Engine Oil-Pressure		Slow
	Turn Signal		Creep
	Engine-Run		Windshield Wiper
	Engine-Start		Windshield Wiper Intermittent
	Engine-Stop		Windshield Washer
	Power Take-Off Clutch Control-Off (Disengaged) Position		Lock
	Power Take-Off Clutch Control-On (Engaged) Position		Rear Window Defroster
	Bi-Speed turn		Steering Wheel-Tilt Control
	Differential Lock		Empty
	Position Control-Raised Position		Full
	Position Control-Lowered Position		PTO 540 rpm
	Draft Control-Shallow Position		PTO 1000 rpm
	Draft Control-Deep Position		Beacon Light

FOREWORD

You are now the proud owner of a KUBOTA Tractor. This tractor is a product of KUBOTA quality engineering and manufacturing. It is made of fine materials and under a rigid quality control system. It will give you long, satisfactory service. To obtain the best use of your tractor, please read this manual carefully. It will help you become familiar with the operation of the tractor and contains many helpful hints about tractor maintenance. It is KUBOTA's policy to utilize as quickly as possible every advance in our research. The immediate use of new techniques in the manufacture of products may cause some small parts of this manual to be outdated. KUBOTA distributors and dealers will have the most up-to-date information. Please do not hesitate to consult with them.



SAFETY FIRST

This symbol, the industry's "Safety Alert Symbol", is used throughout this manual and on labels on the machine itself to warn of the possibility of personal injury. Read these instructions carefully. It is essential that you read the instructions and safety regulations before you attempt to assemble or use this unit.



DANGER : Indicates an imminently hazardous situation which, if not avoided, will result in death or serious injury.



WARNING : Indicates a potentially hazardous situation which, if not avoided, could result in death or serious injury.



CAUTION : Indicates a potentially hazardous situation which, if not avoided, may result in minor or moderate injury.

IMPORTANT : Indicates that equipment or property damage could result if instructions are not followed.

NOTE : Gives helpful information.

CONTENTS

▲ SAFE OPERATION	▲ -1
SERVICING OF TRACTOR.....	1
SPECIFICATIONS.....	2
SPECIFICATION TABLE	2
TRAVELING SPEEDS	4
IMPLEMENT LIMITATIONS	5
INSTRUMENT PANEL AND CONTROLS.....	7
PRE-OPERATION CHECK	11
DAILY CHECK	11
OPERATING THE ENGINE.....	12
STARTING THE ENGINE	12
COLD WEATHER STARTING	14
Block Heater (if equipped)	14
STOPPING THE ENGINE.....	15
WARMING UP	15
Warm-up and Transmission Oil at Low Temperature Range	15
JUMP STARTING	15
OPERATING THE TRACTOR.....	17
OPERATING NEW TRACTOR	17
Do not Operate the Tractor at Full Speed for the First 50 Hours.....	17
Changing Lubricating Oil for New Tractors.....	17
OPERATING FOLDABLE ROPS	17
To Fold the ROPS	17
To Raise the ROPS to Upright Position.....	18
STARTING	19
Operator's Seat.....	19
Seat Belt	19
Muffler.....	19
Tilt Steering Adjustment.....	20
Light Switch	20
Turn Signal / Hazard Light Switch	20
Front Turn Signal / Hazard Light.....	21
With Trailer Connector.....	21
Horn Button.....	21
Front Work Light Switch.....	22
Brake Pedals (Right and Left).....	22
Clutch Pedal	23
Main Gear Shift Lever.....	24
Range Gear Shift Lever	24
Hydraulic-Shuttle Shift Lever	24
Creep Speed.....	25
4WD / Bi-speed Turn Switch.....	25
Hand Throttle Lever	26

Foot Throttle	26
Parking Brake Lever	27
STOPPING.....	27
Stopping.....	27
CHECK DURING DRIVING	27
Immediately Stop the Engine if:.....	27
Easy Checker(TM).....	27
Fuel Gauge	28
Coolant Temperature Gauge	28
Tachometer.....	28
PTO RPM / TRAVEL SPEED MONITOR.....	29
Changing Display Mode.....	29
PTO Speed Display Mode Switching.....	31
Entering the Travel Speed Coefficient.....	32
PARKING	33
Parking.....	33
OPERATING TECHNIQUES	33
Differential Lock.....	33
Operating the Tractor on a Road	34
Operating on Slopes and Rough Terrain	34
Directions for Use of Power Steering.....	34
Trailer Electrical Outlet	34
Electrical Outlet.....	35
PTO	36
PTO OPERATION.....	36
PTO Clutch Control Switch.....	36
PTO Gear Shift Lever	37
LCD Monitor Message	37
PTO Shaft Cover and Shaft Cap	38
THREE-POINT HITCH & DRAWBAR.....	39
3-POINT HITCH	40
Category 1 & 2.....	40
Selecting the holes of Lower Links	40
Selecting the Top Link Mounting Holes	40
Drawbar	41
Lifting Rod (Left).....	41
Lifting Rod (Right).....	41
Top Link.....	42
Stabilizer.....	42
DRAWBAR.....	43
Adjusting Drawbar Length	43
Swing Drawbar	43
HYDRAULIC UNIT.....	44
3-POINT HITCH CONTROL SYSTEM.....	44
Position Control	44
Draft Control	44
Mixed Control.....	44
Float Control	45
3-point Hitch Lowering Speed.....	45
REMOTE HYDRAULIC CONTROL SYSTEM.....	45

Remote Control Valve.....	45
Remote Control Valve Lever.....	45
Remote Control Valve Coupler Connecting and Disconnecting	46
Hydraulic Control Unit Use Reference Chart.....	47
TIRES, WHEELS AND BALLAST	48
TIRES.....	48
Inflation Pressure.....	48
Dual Tires	48
Treads.....	48
BALLAST	49
Front Ballast.....	49
Rear Ballast	49
MAINTENANCE.....	50
SERVICE INTERVALS	50
LUBRICANTS, FUEL AND COOLANT	52
PERIODIC SERVICE.....	54
HOW TO OPEN THE HOOD	54
Hood	54
DAILY CHECK	54
Walk Around Inspection.....	54
Checking and Refueling.....	55
Checking Water Separator	55
Checking Engine Oil Level.....	55
Checking Transmission Fluid Level	56
Checking Coolant Level.....	56
Cleaning Evacuator Valve	56
Cleaning Grill, Radiator Screen, Oil Cooler and Battery Mount.....	57
Checking Brake Pedal	57
Checking Parking Brake	57
Checking Gauges, Meter and Easy Checker(TM).....	57
Checking Head Light, Turn Signal / Hazard Light etc.....	58
Checking Seat Belt and ROPS	58
EVERY 50 HOURS	58
Checking Engine Start System	58
Checking Wheel Bolt Torque	59
EVERY 100 HOURS	59
Lubricating Grease Fittings.....	59
Cleaning Air Cleaner Primary Element.....	60
Adjusting Alternator Belt Tension	61
Checking Fuel Line	61
Adjusting Brake Pedal	61
Adjusting Parking Brake Lever	62
Checking Battery Condition	63
EVERY 200 HOURS	64
Checking Radiator Hose and Clamp	64
Checking Intake Air Line.....	65
Checking Power Steering Line	65
Adjusting Toe-in.....	65
Draining Fuel Tank Water.....	66
EVERY 300 HOURS	66

Changing Engine Oil.....	66
Replacing Hydraulic Oil Filter	67
EVERY 400 HOURS	68
Replacing Fuel Filter.....	68
Cleaning Water Separator	68
EVERY 600 HOURS	69
Replacing Engine Oil Filter	69
Changing Transmission Fluid	69
Changing Front Axle Gear Case Oil & Front Differential Case Oil	70
Adjusting Front Axle Pivot.....	70
EVERY 800 HOURS	70
Adjusting Engine Valve Clearance	70
EVERY 1500 HOURS	70
Checking Fuel Injection Nozzle (Injection Pressure)	70
EVERY 3000 HOURS	71
Checking Turbocharger	71
Checking Injection Pump.....	71
Checking Intake Air Heater.....	71
EVERY 1 YEAR	71
Replacing Air Cleaner Primary Element and Secondary Element.....	71
EVERY 2 YEARS.....	71
Flushing Cooling System and Changing Coolant	71
Anti-Freeze	72
Replacing Radiator Hose (Water pipes)	72
Cleaning Master Cylinder Filter	72
Replacing Power Steering Hose.....	72
Replacing Fuel Hose	72
Replacing Intake Air Line.....	72
Replacing Parking Brake Cable.....	72
Replacing Master Cylinder Kit	73
Replacing Equalizer Kit.....	73
Replacing Brake Seal 1 and 2	73
Replacing Lift Cylinder Hose	73
SERVICE AS REQUIRED.....	73
Bleeding Fuel System.....	73
Bleeding Brake System	74
Draining Clutch Housing Water	74
Replacing Fuse.....	74
Replacing Light Bulb.....	75
Replacing Head Lamp	75
STORAGE	76
TRACTOR STORAGE	76
REMOVING THE TRACTOR FROM STORAGE.....	76
TROUBLESHOOTING.....	77
ENGINE TROUBLESHOOTING	77
OPTIONS.....	78



SAFE OPERATION

Careful operation is your best insurance against an accident.

Read and understand this manual carefully before operating the tractor.

All operators, no matter how much experience they may have, should read this and other related manuals before operating the tractor or any implement attached to it. It is the owner's obligation to instruct all operators in safe operation.

1. BEFORE OPERATING THE TRACTOR

1. Know your equipment and its limitations. Read this entire manual before attempting to start and operate the tractor.
2. Pay special attention to pictorial safety labels on the tractor.
3. Do not operate tractor or any implement attached to it while under the influence of alcohol, medication, controlled substances or while fatigued.
4. Before allowing other people to use your tractor, explain how to operate and have them read this manual before operation.
5. Never wear loose, torn, or bulky clothing around tractor. It may catch on moving parts or controls, leading to the risk of an accident. Use additional safety items, e.g. hard hat, safety boots or shoes, eye and hearing protection, gloves, etc., as appropriate or required.
6. Do not allow passengers to ride on any part of the tractor at anytime. The operator must remain in the tractor seat during operation.
7. Check brakes, clutch, linkage pins and other mechanical parts for improper adjustment and wear. Replace worn or damaged parts promptly. Check the tightness of all nuts and bolts regularly. (For further details, see "MAINTENANCE" section.)
8. Keep your tractor clean. Dirt, grease, and trash build up may contribute to fires and lead to personal injury.
9. Use only implements meeting the specifications listed under "IMPLEMENT LIMITATIONS" in this manual or implements approved by KUBOTA.
10. Use proper weights on the front or rear of the tractor to reduce the risk of upsets. Follow the safe operating procedures specified in the implement or attachment manual.
11. The narrower the tread, the greater the risk of a tractor upset. For maximum stability, adjust the wheels to the widest practical tread width for your application. (See "TIRES, WHEELS AND BALLAST" section.)
12. Do not modify the tractor. Unauthorized modification may affect the function of the tractor, which may result in personal injury.

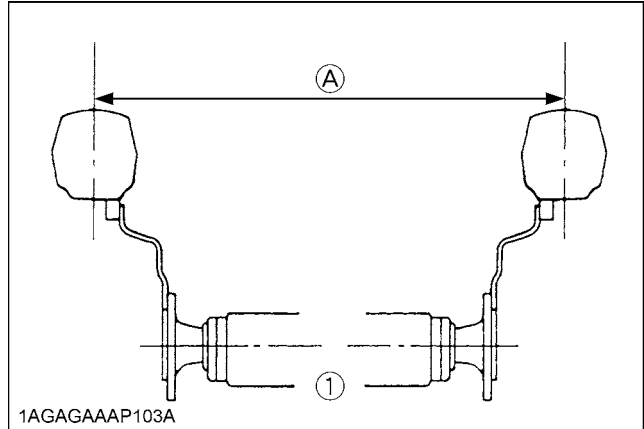

(1) Rear wheels

(A) Tread Width

◆ CAB, ROPS

1. KUBOTA recommends the use of a CAB or Roll Over Protective Structures (ROPS) and seat belt in almost all applications. This combination will reduce the risk of serious injury or death, should the tractor be upset. Check for overhead clearance which may interfere with a CAB or ROPS.
2. If the CAB or ROPS is loosened or removed for any reason, make sure that all parts are reinstalled correctly before operating the tractor.
3. Never modify or repair any structural member of a CAB or ROPS because welding, bending, drilling, grinding, or cutting may weaken the structure.
4. A damaged CAB or ROPS structure must be replaced, not repaired or revised.
5. If any structural member of the CAB or ROPS is damaged, replace the entire structure at your local KUBOTA Dealer.
6. If the tractor is equipped with a foldable ROPS it may be temporarily folded down only when absolutely necessary for areas with height constraints. (There is no operator protection provided by the ROPS in the folded position. For operator safety the ROPS should be placed in the upright and locked position and the seat belt fastened for all other operations.)
7. Always use the seat belt if the tractor has a CAB or ROPS.
Do not use the seat belt if a foldable ROPS is down or there is no ROPS. Check the seat belt regularly and replace if frayed or damaged.

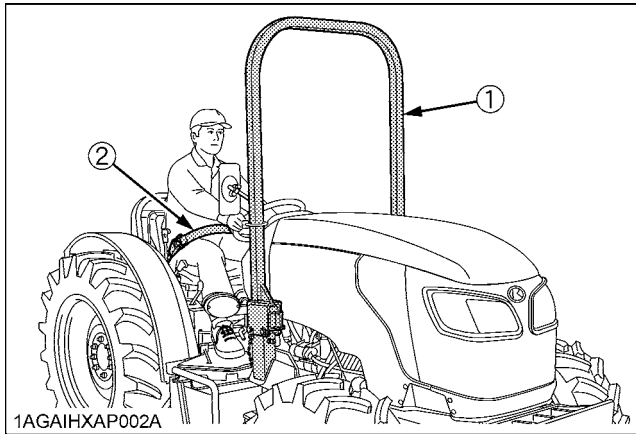

(1) Mid mount type ROPS
(2) Seat belt

2. OPERATING THE TRACTOR

Operator safety is a priority. Safe operation, specifically with respect to overturning hazards, entails understanding the equipment and environmental conditions at the time of use. Some prohibited uses which can affect overturning hazards include traveling and turning with implements and loads carried too high etc. This manual sets forth some of the obvious risks, but the list is not, and cannot be, exhaustive. It is the operator's responsibility to be alert for any equipment or environmental condition that could compromise safe operation.

◆ Starting

1. Always sit in the operator's seat when starting engine or operating levers or controls. Adjust seat per instructions in the operating the tractor section. Never start engine while standing on the ground.
2. Before starting the engine, make sure that all levers (including auxiliary control levers) are in their neutral positions, that the parking brake is engaged, and that both the clutch and the Power Take-Off (PTO) are disengaged or "OFF".
Fasten the seat belt if the tractor has a CAB, a fixed ROPS or a foldable ROPS in the upright and locked position.
3. Do not start engine by shorting across starter terminals or bypassing the safety start switch. Machine may start in gear and move if normal starting circuitry is bypassed.
4. Do not operate or idle engine in a non-ventilated area. Carbon monoxide gas is colorless, odorless, and deadly.
5. Check before each use that operator presence controls are functioning correctly. Test safety systems. (See "Checking Engine Start System" in "EVERY 50 HOURS" in "PERIODIC SERVICE" section.)
Do not operate unless they are functioning correctly.

◆ Working

1. Pull only from the drawbar. Never hitch to axle housing or any other point except drawbar; such arrangements will increase the risk of serious personal injury or death due to a tractor upset.

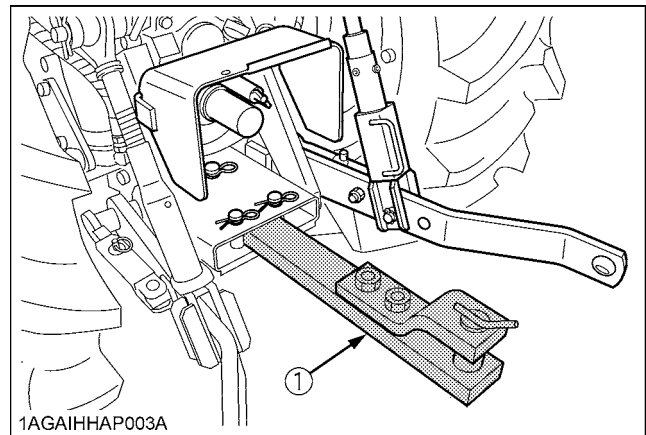

(1) Drawbar

2. For trailing PTO-driven implements, set the drawbar to the towing position.
3. Attach pulled or towed loads to the drawbar only.
4. Keep all shields and guards in place. Replace any that are missing or damaged.
5. Avoid sudden starts. To avoid upsets, slow down when turning, on uneven ground, and before stopping.
6. The tractor cannot turn with the differential locked and attempting to do so could be dangerous.
7. Do not operate near ditches, holes, embankments, or other ground surface features which may collapse under the tractor's weight. The risk of tractor upset is even higher when the ground is loose or wet. Tall grass can hide obstacles, walk the area first to be sure.
8. Watch where you are going at all times. Watch for and avoid obstacles. Be alert at row ends, near trees, and other obstructions.
9. When working in groups, always let the others know what you are going to do before you do it.
10. Never try to get on or off a moving tractor.
11. Always sit in the operator's seat when operating levers or controls.
12. Do not use "Bi-speed Turn" at high speed.
13. "Bi-Speed Turn" enables short and fast turns, therefore, become familiar with its performance before operating in close or confined areas.
14. Do not stand between tractor and implement or trailed vehicle unless parking brake is applied.

◆ Safety for children

Tragedy can occur if the operator is not alert to the presence of children. Children generally are attracted to machines and the work they do.

1. Never assume that children will remain where you last saw them.
2. Keep children out of the work area and under the watchful eye of another responsible adult.

3. Be alert and shut your machine down if children enter the work area.
4. Never carry children on your machine. There is no safe place for them to ride. They may fall off and be run over or interfere with your control of the machine.
5. Never allow children to operate the machine even under adult supervision.
6. Never allow children to play on the machine or on the implement.
7. Use extra caution when backing up. Look behind and down to make sure area is clear before moving.

◆ Operating on slopes

Slopes are major factor related to loss-of-control and tip-over accidents, which can result in severe injury or death. All slopes require extra caution.

1. To avoid upsets, always back up steep slopes. If you cannot back up the slope or if you feel uneasy on it, do not operate on it. Stay off slopes too steep for safe operation.
2. Driving forward out of a ditch, mired condition or up a steep slope increases the risk of a tractor to be upset backward. Always back out of these situations. Extra caution is required with four-wheel drive models because their increased traction can give the operator false confidence in the tractor's ability to climb slopes.
3. Keep all movement on slopes slow and gradual. Do not make sudden changes in speed, direction or apply brake and make sudden motions of the steering wheel.
4. Avoid disengaging the clutch or changing gears speed when climbing or going down a slope. If on a slope disengaging the clutch or changing gears to neutral could cause loss of control.
5. Special attention should be made to the weight and location of implements and loads as such will affect the stability of the tractor.
6. To improve stability on slope, set widest wheel tread as shown in "TIRES, WHEELS AND BALLAST" section.
Follow recommendations for proper ballasting.
7. To avoid free wheeling:
 - Do not shift the shuttle lever while on a slope.
 - Stop completely by using the brake and by depressing the clutch pedal, then shift the shuttle lever.
 - Start off after selecting shuttle direction, by releasing the clutch pedal.

◆ Driving the tractor on the road

1. Lock the two brake pedals together to help assure straight-line stops. Uneven braking at road speeds could cause the tractor to tip over.

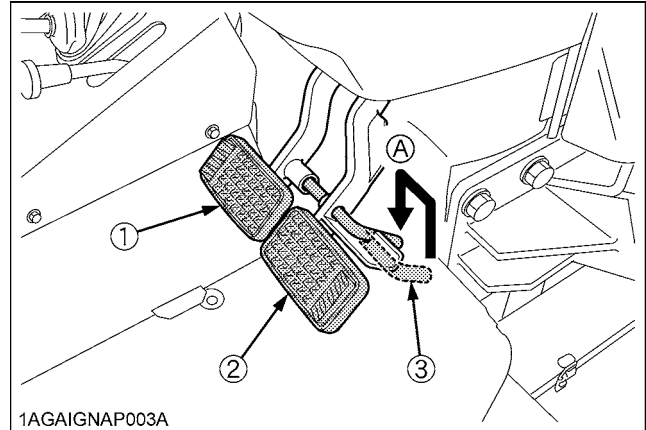

1AGAIGNAP003A

- (1) Brake Pedal (LH) (A) Whenever travelling on the road
 (2) Brake Pedal (RH)
 (3) Brake Pedal Lock

2. Check the front wheel engagement. The braking characteristics are different between two and four wheel drive. Be aware of the difference and use carefully.
3. Always slow the tractor down before turning. Turning at high speed may tip the tractor over.
4. Observe all local traffic and safety regulations. Use the registration plate as required.

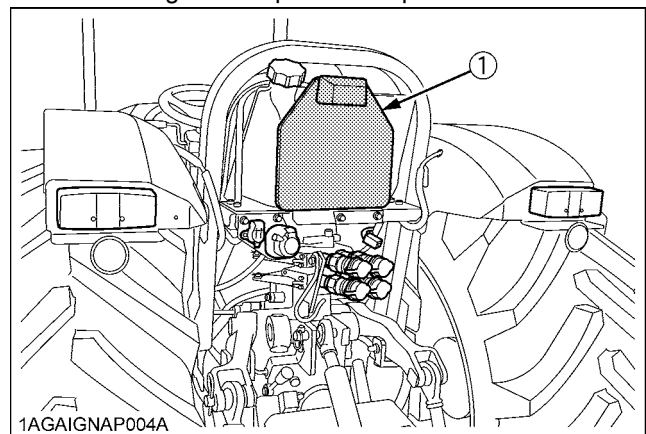

1AGAIGNAP004A

- (1) Registration plate

5. Turn the headlights on. Dim them when meeting another vehicle.
6. Drive at speeds that allow you to maintain control at all times.
7. Do not apply the differential lock while traveling at road speeds. The tractor may run out of control.
8. Avoid sudden motions of the steering wheel as they can lead to a dangerous loss of stability. The risk is especially great when the tractor is traveling at road speeds.

▲-4 SAFE OPERATION

9. Keep the ROPS in the "UP" position and wear the seat belt when driving the tractor on the road. Otherwise, you will not be protected in the event of a tractor roll-over.
10. Do not operate an implement while the tractor is on the road. Lock the 3-point hitch in the raised position.
11. Do not ride or stand on the step during operation. Riding or standing there could result in being crushed under the rear tire due to slippage or the step fracturing or displacing due to unintended loading.

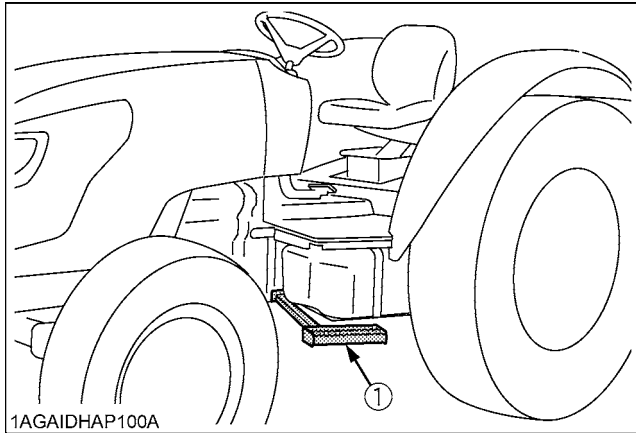

(1) Step

12. Set the implement lowering speed lever in the "LOCK" position to hold the implement in the raised position.

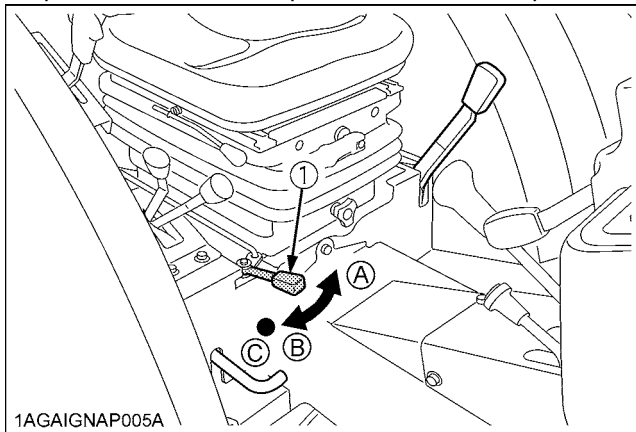

(1) 3-point hitch lowering speed lever

(A) "FAST"
(B) "SLOW"
(C) "LOCK"

3. PARKING THE TRACTOR

1. Disengage the PTO, lower all implements to the ground, place all control levers in their neutral positions, set the parking brake, stop the engine, remove the key from the ignition and lock the cab door (if equipped). Leaving transmission in gear with the engine stopped will not prevent tractor from rolling.
2. Make sure that the tractor has come to a complete stop before dismounting.

3. Avoid parking on steep slopes, if at all possible park on a firm and level surface; if not, park across a slope with chock the wheels. Failure to comply with this warning may allow the tractor to move and could cause injury or death.

4. OPERATING THE PTO

1. Wait until all moving components have completely stopped before getting off the tractor, connecting, disconnecting, adjusting, cleaning, or servicing any PTO driven equipment.
2. Keep the PTO shaft cover in place at all times. Replace the PTO shaft cap when the shaft is not in use.

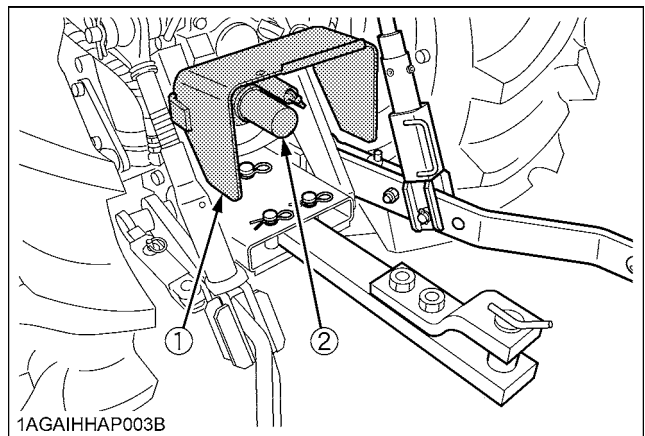

(1) PTO Shaft cover
(2) PTO Shaft cap

3. Before installing or using PTO driven equipment, read the manufacturer's manual and review the safety labels attached to the equipment.
4. When operating stationary PTO driven equipment, always apply the tractor parking brake and place chocks behind and in front of the rear wheels. Stay clear of all rotating parts. Never step over rotating parts.

5. USING 3-POINT HITCH

1. Use the 3-point hitch only with equipment designed for 3-point hitch usage.
2. When using a 3-point hitch mounted implement, be sure to install the proper counterbalance weight on the front of the tractor.

3. To avoid injury from separation:
Do not extend lift rod beyond the groove on the threaded rod.

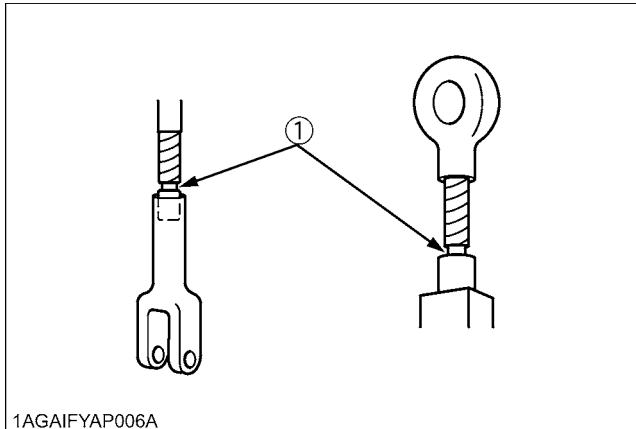

(1) Groove

6. SERVICING THE TRACTOR

Before servicing the tractor, park it on a firm, flat and level surface, set the parking brake, lower all implements to the ground, place the gear shift lever in neutral, stop the engine and remove the key.

1. Allow the tractor time to cool off before working on or near the engine, muffler, radiator, etc.
2. Do not remove radiator cap while coolant is hot. When cool, slowly rotate cap to the first stop and allow sufficient time for excess pressure to escape before removing the cap completely. If the tractor has a coolant recovery tank, add coolant or water to the tank, not the radiator. (See "Checking Coolant Level" in "DAILY CHECK" in "PERIODIC SERVICE" section.)
3. Always stop the engine before refueling. Avoid spills and overfilling.
4. Do not smoke when working around battery or when refueling. Keep all sparks and flames away from battery and fuel tank. The battery presents an explosive hazard, because it gives off hydrogen and oxygen especially when recharging.
5. Before "jump starting" a dead battery, read and follow all of the instructions. (See "JUMP STARTING" in "OPERATING THE ENGINE" section.)
6. Keep first aid kit and fire extinguisher handy at all times.
7. Disconnect the battery's ground cable before working on or near electric components.
8. To avoid the possibility of battery explosion, do not use or charge the refillable type battery if the fluid level is below the LOWER (lower limit level) mark. Check the fluid level regularly and add distilled water as required so that the fluid level is between the UPPER and LOWER levels.

9. To avoid sparks from an accidental short circuit, always disconnect the battery's ground cable (-) first and reconnect it last.

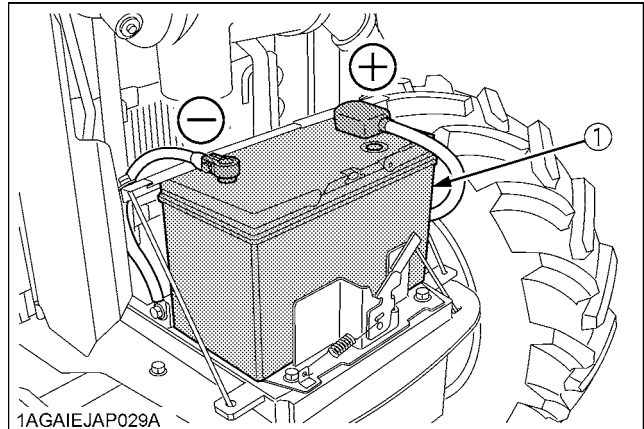

(1) Battery

10. Do not attempt to mount a tire on a rim. This should be done by a qualified person with the proper equipment.
11. Always maintain the correct tire pressure. Do not inflate tires above the recommended pressure shown in the operator's manual.

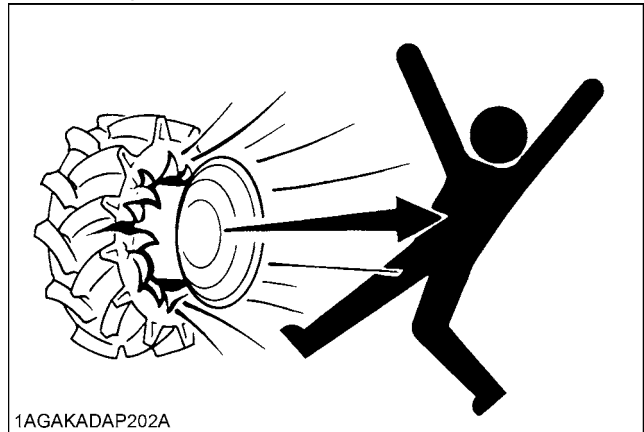

12. Securely support the tractor when either changing wheels or adjusting the wheel tread width.
13. Make sure that wheel bolts have been tightened to the specified torque.
14. Disconnect the battery's ground cable and stop the engine to avoid the possibility of the machine runaway due to 4WD braking system during testing, service or repair with only rear wheels off the ground.
15. Do not work under any hydraulically supported devices. They can settle, suddenly leak down, or be accidentally lowered. If it is necessary to work under tractor or any machine elements for servicing or adjustment, securely support them with stands or suitable blocking beforehand.

▲-6 SAFE OPERATION

16. Escaping hydraulic fluid under pressure has sufficient force to penetrate skin, causing serious personal injury. Before disconnecting hydraulic lines, be sure to release all residual pressure. Before applying pressure to the hydraulic system, make sure that all connections are tight and that all lines, pipes, and hoses are free of damage.



17. Fluid escaping from pinholes may be invisible. Do not use hands to search for suspected leaks; use a piece of cardboard or wood. Use of safety goggles or other eye protection is also highly recommended. If injured by escaping fluid, see a medical doctor at once. This fluid will produce gangrene or severe allergic reaction.

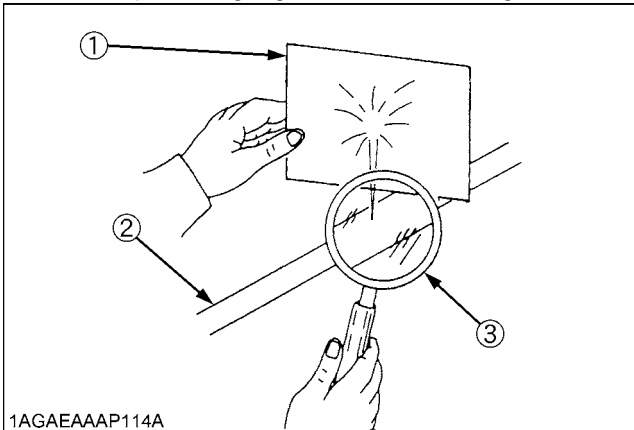

- (1) Cardboard
- (2) Hydraulic line
- (3) Magnifying glass

7. PICTORIAL SAFETY LABELS

The pictorial safety labels affixed are intended to alert persons to potential hazards. The hazard is identified by a pictorial in the safety alert triangle or by the safety alert symbol alone. An adjacent pictorial provides instructions and information on how to avoid the hazard.

(1) Part No. K3512-4718-1

Start engine from operator's seat only.

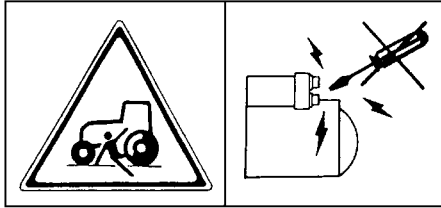

1BDABANAP083B

(2) Part No. TD179-3491-1

Carefully read operator's manual before handling the machine. Observe instructions and safety rules when operating.

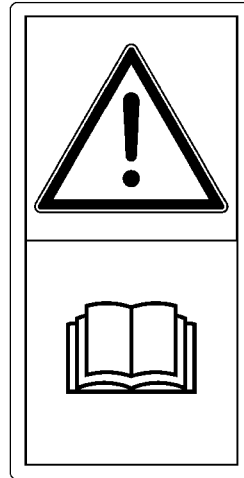

1AGAWAEP088A

(3) Code No. TD179-4902-1

Seat belt should be used.

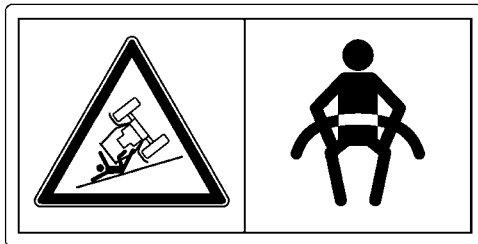

1AGAWAEP086A

(4) Part No. 3A481-9853-1

Diesel fuel only. No fire.

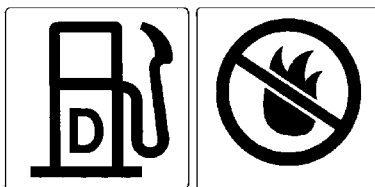

1AGAIAZAP118A

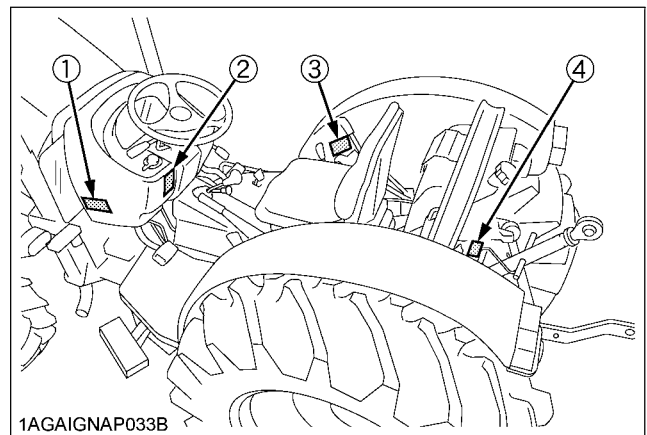

1AGAIGNAP033B

1AGAIGNAP062A

(1) Code No. TD169-9848-1

Always lock ROPS in upright position unless it has to be folded down to allow operation underneath trees or bushes. When ROPS is locked in upright position seat belt should be used.

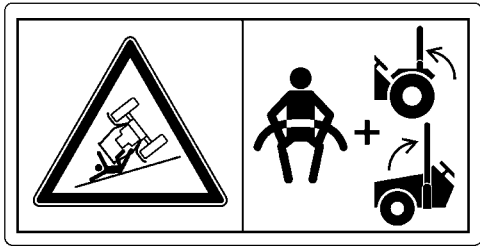

1AGAWAEP087A

(2) Part No. 3A481-9852-1



1AGAOAJAP066A

(3) Part No. 6C090-4958-2

Do not get your hands close to engine fan and fan belt.



1AGAIAZAP110A

(4) Part No. 3Y205-9892-1

⚠ DANGER/POISON

 SHIELD EYES. EXPLOSIVE GASES CAN CAUSE BLINDNESS OR INJURY.	 NO SPARKS FLAMES OR SMOKING, SEVERE BURNS.	 SULFURIC ACID CAN CAUSE BLINDNESS OR SEVERE BURNS.
---	--	--

KEEP OUT OF REACH OF CHILDREN. DO NOT TIP. DO NOT OPEN BATTERY.

FLUSH EYES IMMEDIATELY WITH WATER. **GET MEDICAL HELP FAST.**

PROPOSITION 65 WARNING
 BATTERY POSTS, TERMINALS, AND RELATED ACCESSORIES CONTAIN LEAD AND LEAD COMPOUNDS, CHEMICALS KNOWN TO THE STATE OF CALIFORNIA TO CAUSE CANCER AND REPRODUCTIVE HARM. WASH HANDS AFTER HANDLING.

105E41R 12V	
AMP. HR (5HR)	80
AMP. HR (20HR)	100
RESERVE CAPACITY (MIN)	160
BCI CCA	900
EN CCA	800

S.O.C. INDICATOR

ON

CHARGE REPLACE BATTERY

REPLACE BATTERY

Pb

DK 85330

1AGAIJHAP083A

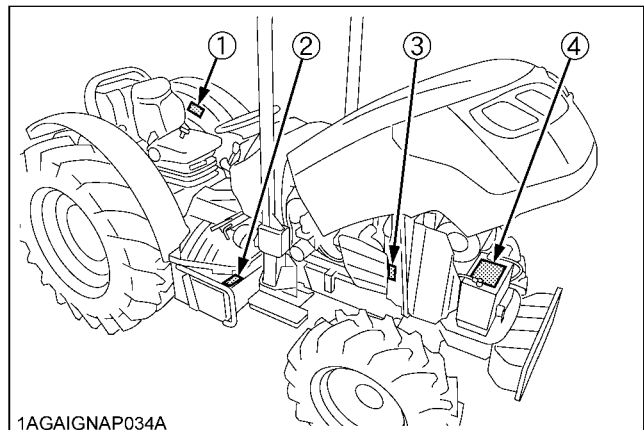

1AGAINAP034A

1AGAINAP040A

(1) Part No. 6C090-4958-2

Do not get your hands close to engine fan and fan belt.



1AGAIAZAP110A

(2) Part No. K3512-4719-1

Do not touch hot surface like muffler, etc.



1BDABANAP080A

(3) Part No. TA040-4958-1

Do not touch hot surface like muffler, etc.



1AGAMAAP2400

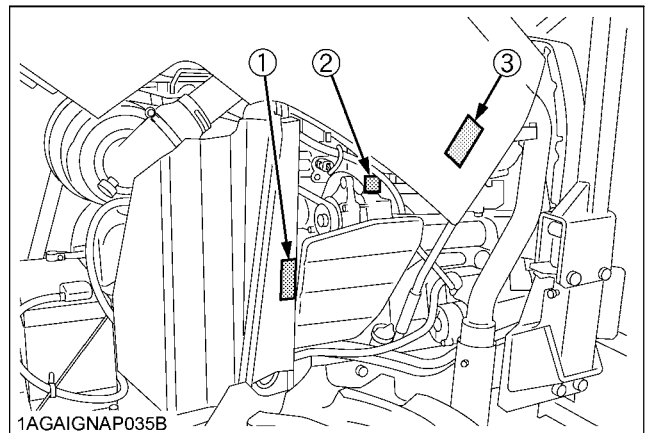

1AGAIGNAP035B

1AGAIGNAP063A

8. CARE OF PICTORIAL SAFETY LABELS

1. Keep pictorial safety labels clean and free from obstructing material.
2. Clean pictorial safety labels with soap and water, dry with a soft cloth.
3. Replace damaged or missing pictorial safety labels with new labels from your local KUBOTA Dealer.
4. If a component with pictorial safety label(s) affixed is replaced with new part, make sure new label(s) is (are) attached in the same location(s) as the replaced component.
5. Mount new pictorial safety labels by applying on a clean dry surface and pressing any bubbles to outside edge.

SERVICING OF TRACTOR

Your dealer is interested in your new tractor and has the desire to help you get the most value from it. After reading this manual thoroughly, you will find that you can do some of the regular maintenance yourself.

However, when in need of parts or major service, be sure to see your KUBOTA Dealer.

For service, contact the KUBOTA Dealership from which you purchased your tractor or your local KUBOTA Dealer. When in need of parts, be prepared to give your dealer the tractor, CAB/ROPS and engine serial numbers.

Locate the serial numbers now and record them in the space provided.

	Type	Serial No.
Tractor		
CAB / ROPS		
Engine		
Date of Purchase		
Name of Dealer		
(To be filled in by purchaser)		

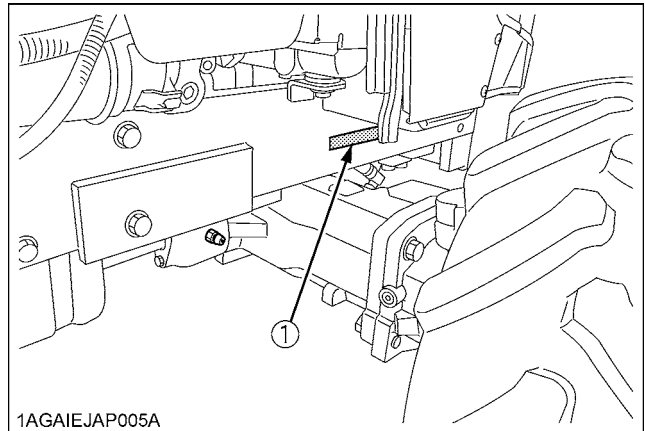

(1) Tractor serial number

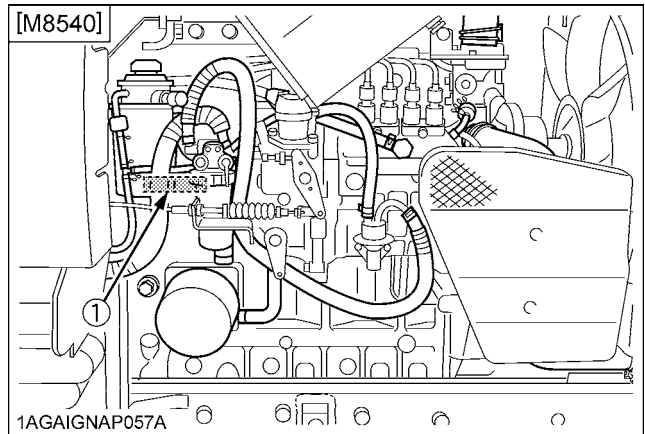

(1) Engine serial number

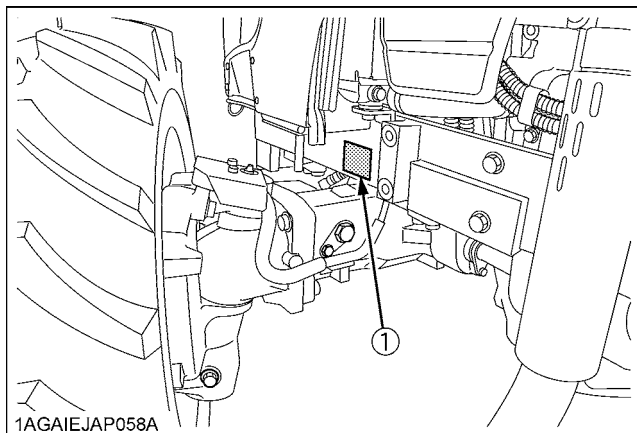

(1) Tractor identification plate

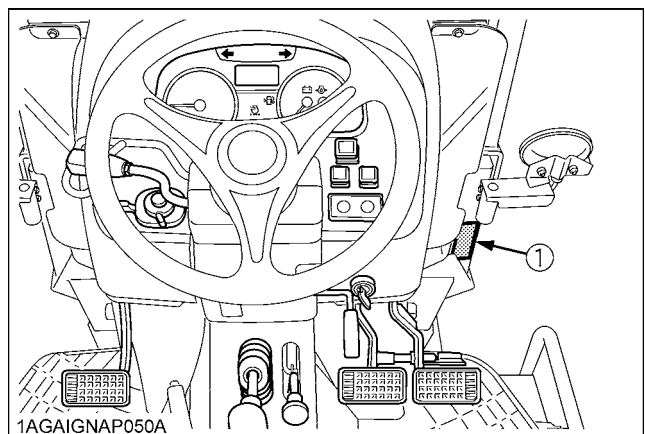

(1) ROPS identification plate (ROPS Serial No.)

SPECIFICATIONS

SPECIFICATION TABLE

Model			M8540N
			4WD
Engine	Model		V3800-DI-TE3
	Type		Direct Injection, liquid cooled 4 cylinder diesel
	Number of cylinders		4
	Total displacement	cm ³	3769
	Bore and stroke	mm	100 x 120
	Rated speed	rpm	2600
	Net power *1	kW (PS)	63.7 (86.7)
	Gross power *1	kW (PS)	66.7 (90.7)
	Maximum torque	N-m / rpm	286 / 1500 to 1700
	Battery capacity		12V, RC: 160 min, CCA 900A
	Fuel tank capacity	L	60
	Engine oil capacity	L	10.7
Coolant capacity	L	9.0	
Dimensions	Overall length (with 3P)		mm 3620
	Overall width (minimum tread)		mm 1486
	Overall height (with top of steering wheel)		mm 1460
	Wheel base		mm 2050
	Tread	Front	mm 1150
		Rear	mm 1066
Minimum ground clearance		mm 325 (Drawbar bracket)	
Weight (with ROPS)		kg 2305	
Traveling system	Standard tire size	Front tires	280 / 70R18
		Rear tires	420 / 70R24
	Clutch		Multiple wet disks
	Steering		Hydraulic Power Steering
	Braking system		Hydraulic wet disks mechanical
Differential		Bevel gears with differential lock (Rear)	



Model			M8540N		
			4WD		
Hydraulic unit	Hydraulic control system		Position, draft (top link sensing) & mix control		
	Pump capacity	L / min	61		
	Three point hitch		Category 1 (Category 2 Link end)		
	Max. lifting force	At lifting points	kg	2300 At lower link end with links horizontal	
		24 in. behind lifting point	kg	1800	
	Remote hydraulic control		2 standard (3rd valve optional)		
	System pressure	MPa (kgf/cm ²)	19.1 (195)		
	Traction system		Swinging drawbar, adjustable in direction		
PTO	Live PTO (Independent)	Direction of turning		Clockwise, viewed from tractor rear	
		PTO/ Engine speed	rpm	6 spline: 540 / 2160	

The company reserves the right to change the specifications without notice.

NOTE: *1 Manufacturer's estimate

TRAVELING SPEEDS

(At rated engine rpm)

Model		M8540N	
Tire size (Rear)		420 / 70R24	
Shuttle shift lever	Range gear shift lever	Main gear shift lever	km/h
Forward 	CREEP	1	0.38
		2	0.55
		3	0.71
		4	0.90
		5	1.19
	L	1	2.7
		2	3.8
		3	4.9
		4	6.3
		5	8.4
	H	1	10.9
		2	15.4
		3	19.8
		4	25.3
		5	33.4
Reverse 	CREEP	1	0.36
		2	0.52
		3	0.67
		4	0.86
		5	1.13
	L	1	2.6
		2	3.7
		3	4.7
		4	6.1
		5	8.0
	H	1	10.3
		2	14.6
		3	18.9
		4	24.2
		5	31.8

The company reserves the right to change the specifications without notice

IMPLEMENT LIMITATIONS

The KUBOTA Tractor has been thoroughly tested for proper performance with implements sold or approved by KUBOTA. Use with implements which are not sold or approved by KUBOTA and which exceed the maximum specifications listed below, or which are otherwise unfit for use with the KUBOTA Tractor may result in malfunctions or failures of the tractor, damage to other property and injury to the operator or others. [Any malfunctions or failures of the tractor resulting from use with improper implements are not covered by the warranty.]

Tread (max. width)		Lower link end max. lifting capacity: W 0
Front	Rear	
1150 mm	1066 mm	2300 kg

Actual figures		
Implement weight: W 1 and / or size	Max. drawbar Load: W 2	Trailer loading weight: W 3 Max. capacity
As in the following list (Shown on the next page)	1000 kg	5000 kg

Lower link end max, hydraulic lifting capacity.....W 0
 Implement weight.....The implement's weight which can be put on the lower link: W 1
 Max. drawbar load.....W 2
 Trailer loading weight.....The max. loading weight for trailer (without trailer's weight): W 3

1AGAIAZAP121B

NOTE :
 ● Implement size may vary depending on soil operating conditions.

6 IMPLEMENT LIMITATIONS

No.	Implement		Remarks		M8540N	
					4WD	
1	Trailer		Max. Load Capacity	kg	5000	
			Max. Drawbar Load	kg	1000	
2	Mower	Rotary-Cutter	Max. Cutting Width	mm	2130	
			Max. Weight	kg	540	
		Flail Mower (Heavy)	Max. Cutting Width	mm	3050	
			Max. Weight	kg	800	
Sickle Bar	Max. Cutting Width	mm	2130			
3	Sprayer		Max. Tank-Capacity	Mid	L	680
				Rear 3P	L	680
				Drawbar	L	4000
4	Rotary Tiller		Max. Tilling Width	mm	2130	
			Max. Weight	kg	800	
5	Bottom Plow		Max. Size		14 in. x 3 16 in. x 2 18 in. x 1	
			Max. Weight	kg 3P Type	450	
6	Disk harrow	3P Type	Max. Size		18 in. x 24	
			Max. Harrowing Width	mm	2130	
			Max. Weight	kg	450	
		Drawbar	Max. Harrowing Width	mm	2750	
7	Disc Plow		Max. Size		24 in. x 3 26 in. x 2	
			Max. Weight	kg	450	
8	Sub Soiler		Numbers of Cultivating Tines		2	
			Cultivating Depth	mm	400	
9	Cultivator		Max. Width	mm	3660	
			Number of Rows		4	
			Max. Weight	kg	450	

NOTE :

- Implement size may vary depending on soil operating conditions.

INSTRUMENT PANEL AND CONTROLS

■ Instrument Panel, Switches and Hand Controls

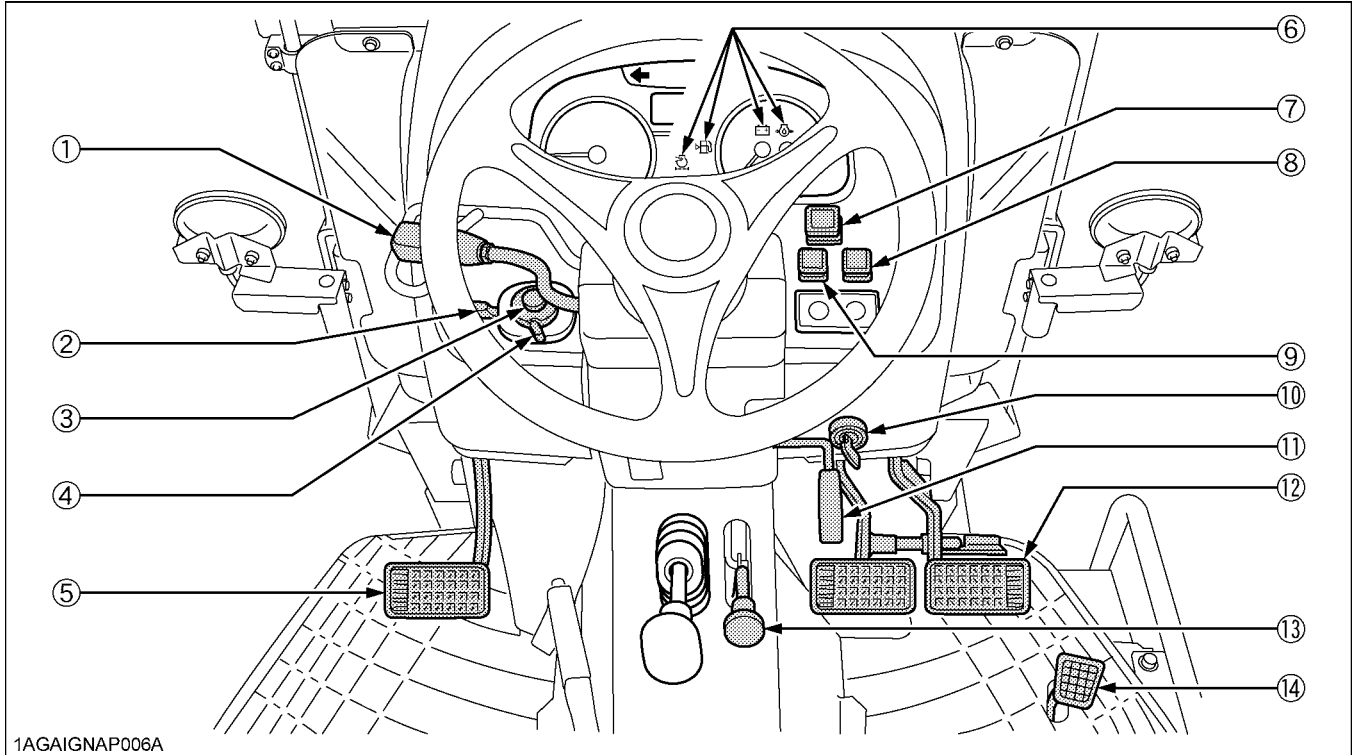

ILLUSTRATED CONTENTS

(1) Hydraulic-shuttle shift lever.....	24
(2) Turn signal light switch.....	20
(3) Horn button.....	21
(4) Head light switch.....	20
(5) Clutch pedal.....	23
(6) Easy Checker(TM).....	27
(7) 4WD / Bi-Speed Turn switch.....	25
(8) Hazard light switch.....	20
(9) Front work light switch.....	22
(10) Key switch.....	-
(11) Hand throttle lever.....	26
(12) Brake pedal.....	22
(13) Tilt lever.....	20
(14) Foot throttle.....	26

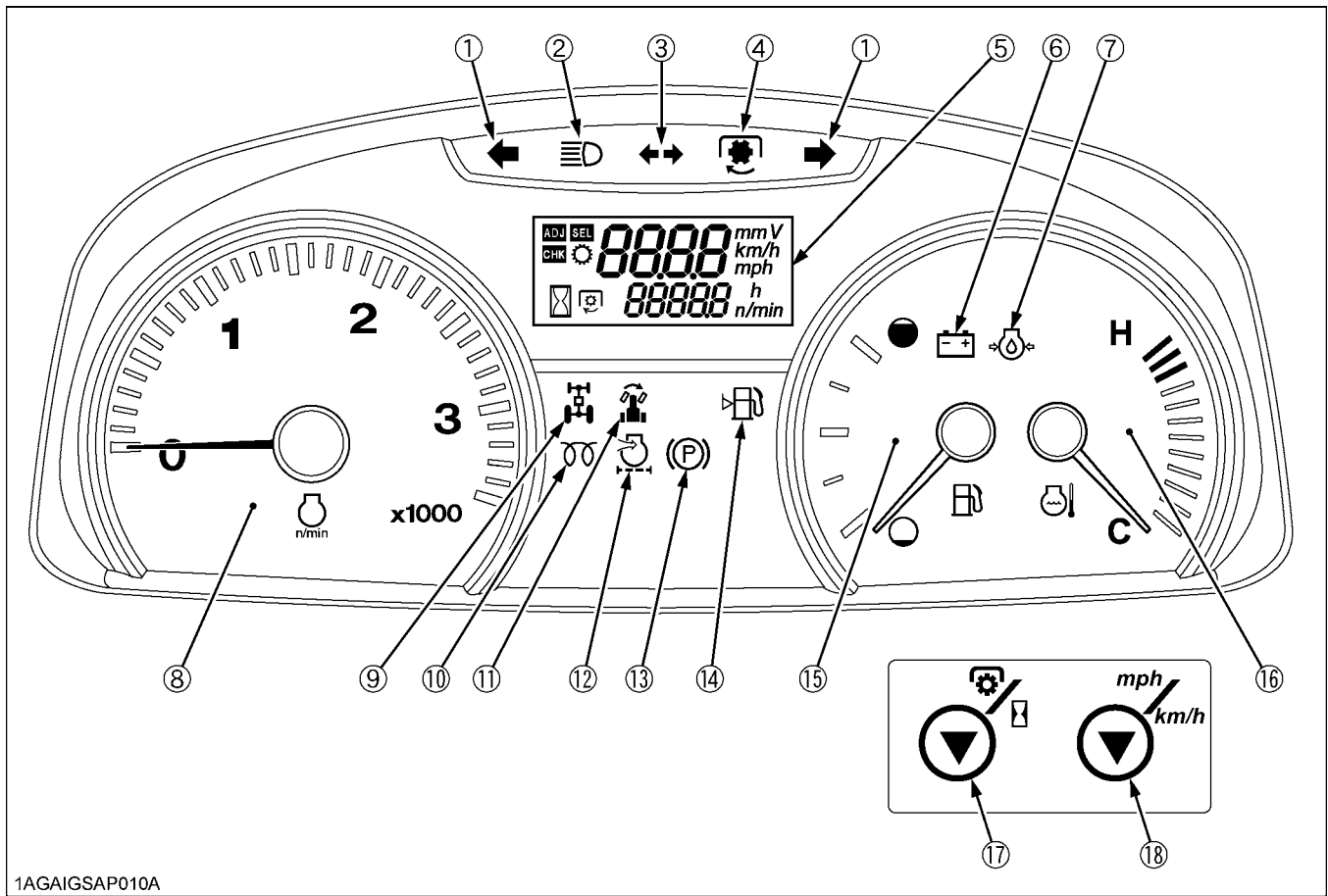

1AGAIGSAP010A

ILLUSTRATED CONTENTS

(1) Hazard / Turn signal indicator	20
(2) High beam indicator	20
(3) Trailer indicator.....	21
(4) PTO clutch indicator.....	36
(5) Liquid crystal display	29
(6) Electrical charge indicator	27
(7) Engine oil pressure	27
(8) Tachometer	28
(9) 4WD indicator	25
(10) Heater indicator	14

ILLUSTRATED CONTENTS

(11) Bi-Speed Turn indicator.....	25
(12) Air cleaner indicator.....	27
(13) Parking brake indicator	27
(14) Fuel level indicator	27
(15) Fuel gauge.....	28
(16) Coolant temperature gauge.....	28
(17) PTO / Hour meter select switch.....	29
(18) Travel speed select switch.....	29

■ Foot and Hand Controls

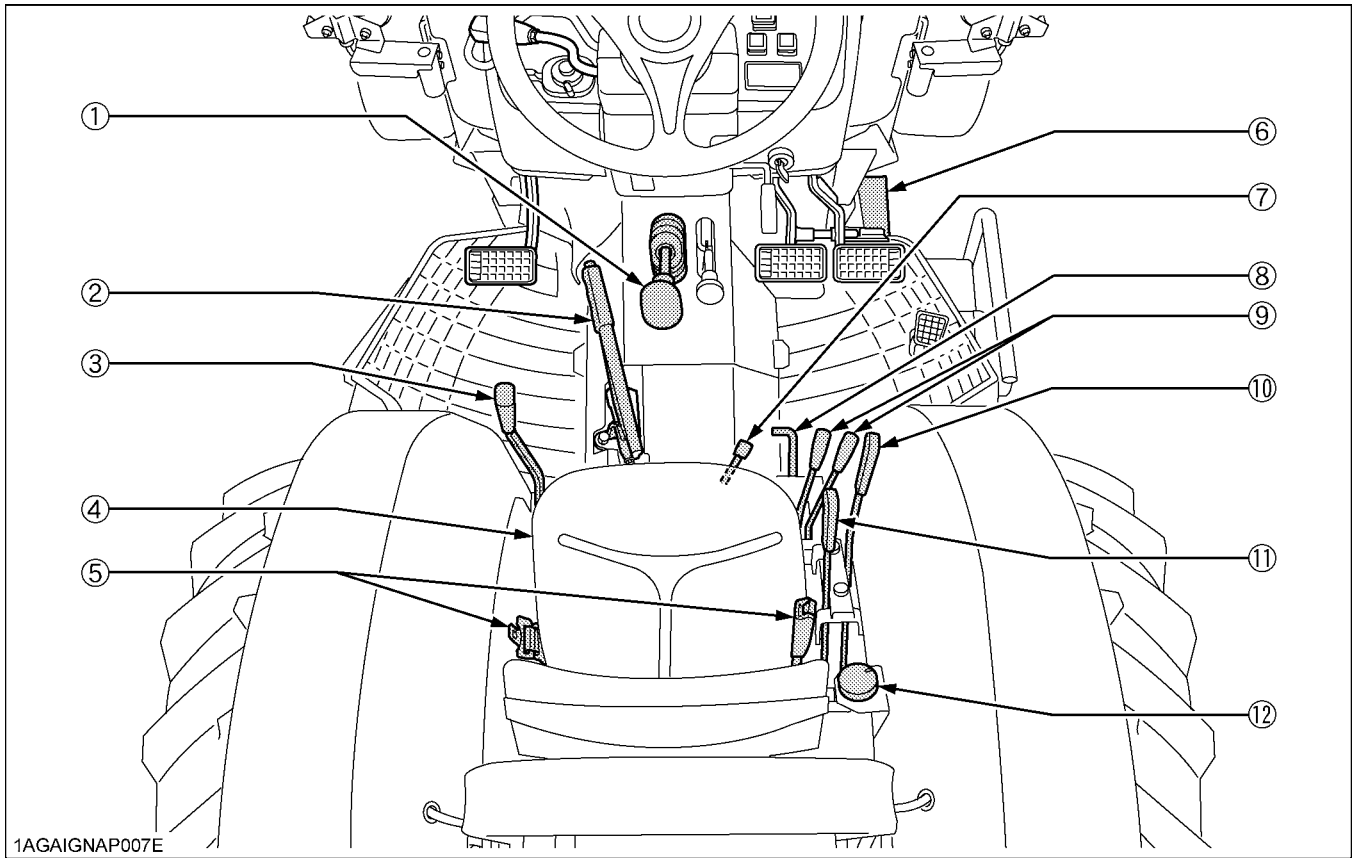

1AGAIGNAP007E

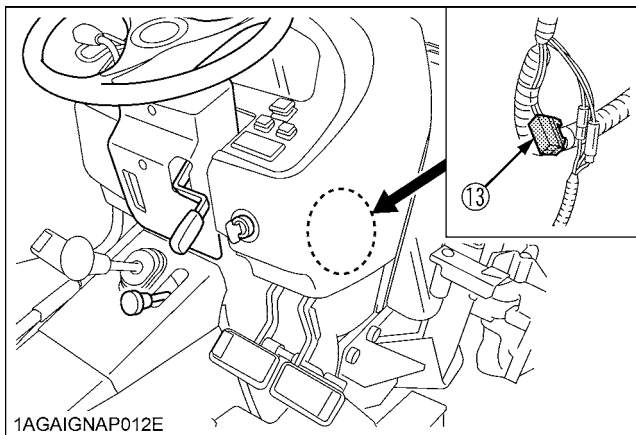

1AGAIGNAP012E

ILLUSTRATED CONTENTS

(1) Main gear shift lever.....	24
(2) Parking brake lever.....	27, 33
(3) Range gear shift lever.....	24
(4) Operator's seat.....	19
(5) Seat belt.....	19
(6) Tool box.....	-
(7) 3-Point hitch lowering speed lever.....	45
(8) Differential lock pedal.....	33
(9) Remote control valve lever.....	45
(10) Position control lever.....	44
(11) Draft control lever.....	44
(12) PTO clutch control switch.....	36
(13) Electrical outlet.....	35

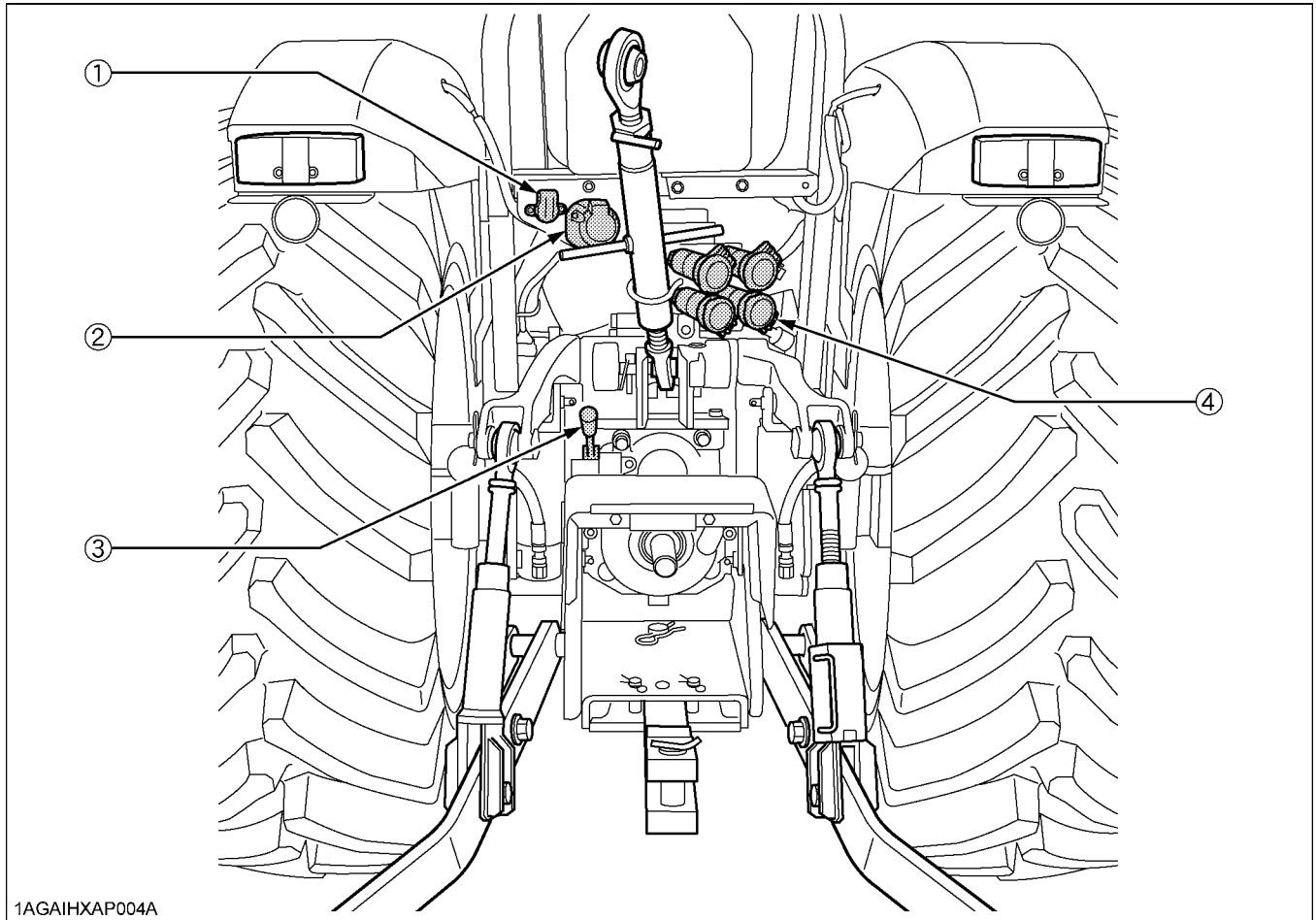

ILLUSTRATED CONTENTS

(1) Electrical outlet.....	35
(2) Trailer electrical outlet.....	34
(3) PTO gear shift lever.....	37
(4) Remote control valve coupler.....	46

PRE-OPERATION CHECK

DAILY CHECK

To prevent trouble from occurring, it is important to know the condition of the tractor well. Check it before starting.



CAUTION

To avoid personal injury:

- **Be sure to check and service the tractor on a level surface with the engine shut off and the parking brake "ON" and implement lowered to the ground.**

Check item

- Walk around inspection
- Check engine oil level
- Check transmission oil level
- Check coolant level
- Check water separator
- Clean grill and radiator screen
- Clean oil cooler
- Check air cleaner evacuator valve
(When used in a dusty place)
- Check brake pedal
- Check parking brake lever
- Check indicators, gauges and meter
- Check lights
- Check seat belt and ROPS
- Refuel
(See "DAILY CHECK" in "PERIODIC SERVICE" section.)
- Care of pictorial safety labels
(See "PICTORIAL SAFETY LABELS" in "SAFE OPERATION" section.)

OPERATING THE ENGINE



CAUTION

To avoid personal injury:

- Read "Safe Operation" in the front of this manual.
- Understand the pictorial safety labels located on the tractor.
- To avoid the danger of exhaust fume poisoning, do not operate the engine in a closed building without proper ventilation.
- Never start engine while standing on ground. Start engine only from operator's seat.
- Make it a rule to set all shift levers to the "NEUTRAL" positions and to place PTO clutch control switch in "OFF" position before starting the engine.

IMPORTANT :

- Do not use starting fluid or ether.
- To protect the battery and the starter, make sure that the starter is not continuously turned for more than 10 seconds.

STARTING THE ENGINE

1. Make sure the parking brake is set.

Pull the parking brake lever up to park. The parking brake indicator light on the Easy Checker(TM) will come on while the parking brake is set.

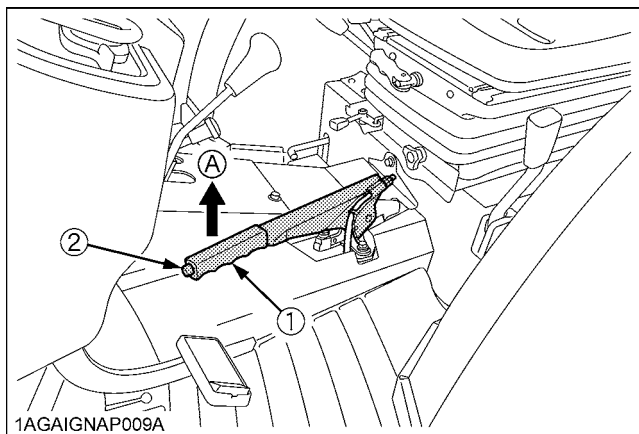

(1) Parking brake lever (A) "PULL"
(2) Release button

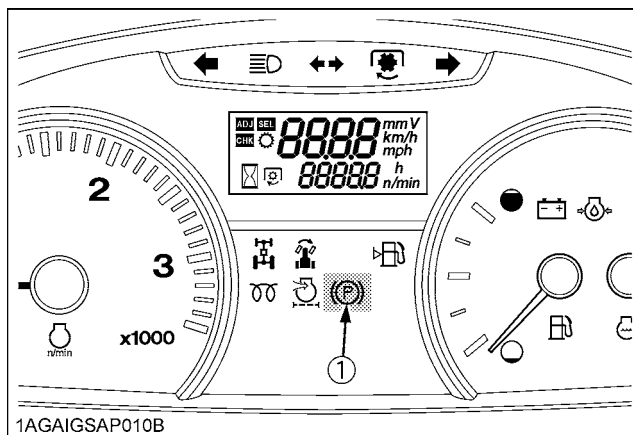

(1) Parking brake indicator light

IMPORTANT :

- If the tractor is operated with the parking brake set, the parking brake will be damaged.

2. Make sure the fuel cock is in the "OPEN" position.

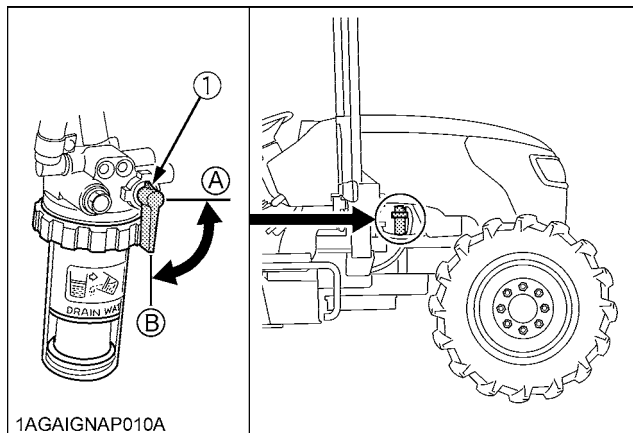

(1) Fuel cock (A) "CLOSE" (B) "OPEN"

3. Place the shift levers in "NEUTRAL" position.

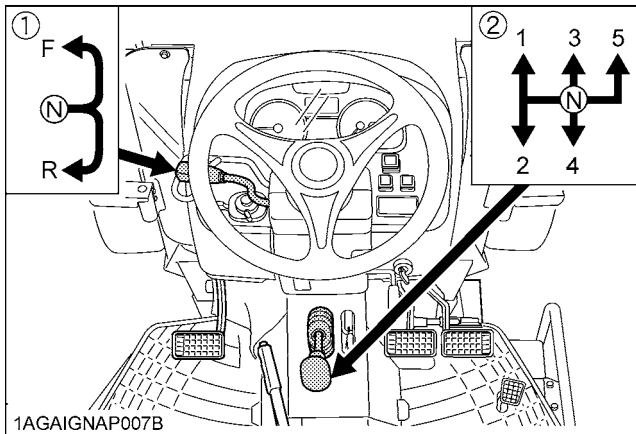

(1) Hydraulic-shuttle shift lever (N) "NEUTRAL POSITION"
 (2) Main gear shift lever

5. Set the throttle lever to about 1/2 way.

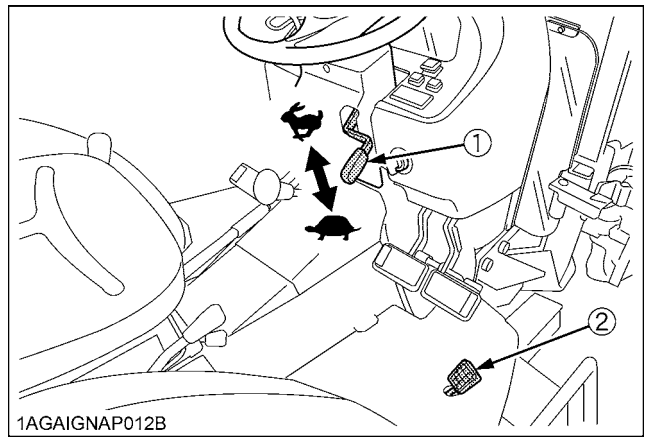

(1) Hand throttle lever "INCREASE"
 (2) Foot throttle "DECREASE"

4. Place the PTO clutch control switch in "OFF" position and hydraulic control levers in "LOWEST" position.

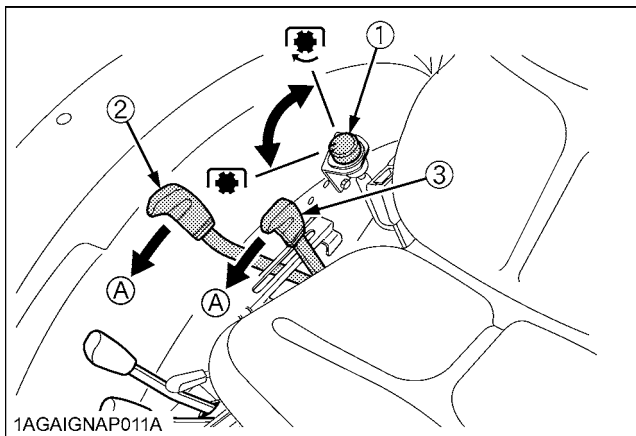

(1) PTO clutch control switch "ON" "OFF"
 (2) Position control lever (A) "DOWN"
 (3) Draft control lever

6. Insert the key into the key switch and turn it "ON".

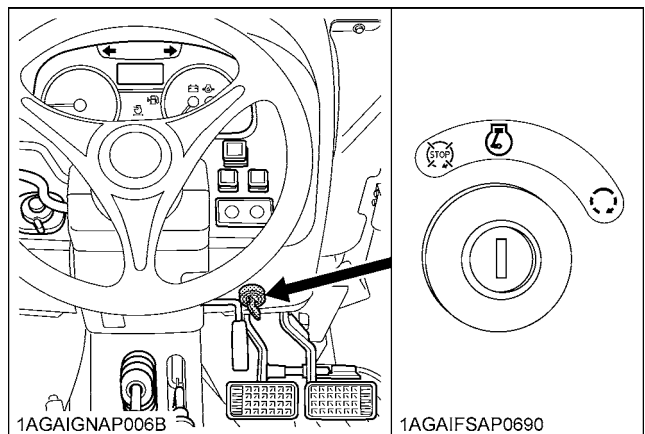

STOP "OFF" (Engine-Stop) START "START" (Engine-Start)
 "ON" (Engine-Run)

◆ Check Easy Checker(TM) Lamps:

1. When the key is turned "ON", lamps (2) (3) (5) should come on. If trouble should occur at any location while the engine is running, the indicator lamp corresponding to that location comes on.
2. Suppose that the engine coolant temperature is not high enough yet. The heater indicator (4) also comes on when the key is turned "ON" to preheat the engine and goes off automatically when preheat is completed. Illumination time of indicator varies according to the temperature of coolant
3. The PTO clutch indicator (1) comes on while PTO clutch control switch is engaged "ON" and goes off when disengaged "OFF" it.

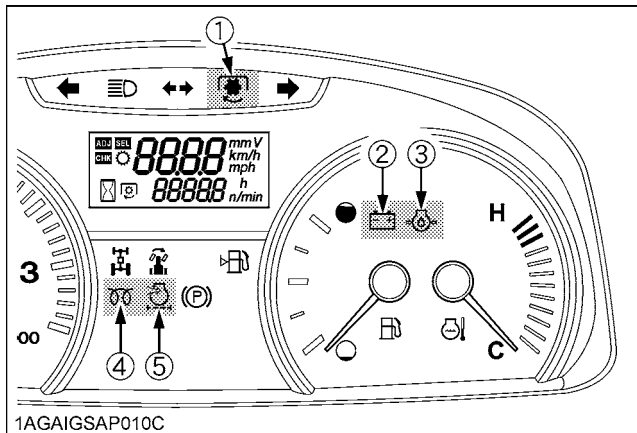

- (1) PTO clutch indicator
 (2) Electrical charge indicator
 (3) Engine oil pressure indicator
 (4) Heater indicator
 (5) Air cleaner indicator

NOTE :

- Some of the Easy Checker(TM) lamps may come on or go off depending on the positions of the lever and switch.

IMPORTANT :

- Daily checks with the Easy Checker(TM) only, are not sufficient. Never fail to conduct daily checks carefully by referring to Daily Check. (See "DAILY CHECK" in "PERIODIC SERVICE" section.)

7. Fully depress the clutch pedal.**8. Turn the key to "START" position and release when the engine starts.****IMPORTANT :**

- Because of the safety devices, the engine will not start except when the PTO clutch control switch is placed in the "OFF" position and shuttle shift lever is placed in the "NEUTRAL" position.

9. Check to see that all the lamps on the Easy Checker(TM) are "OFF".

If a lamp is still on, immediately stop the engine and determine the cause.

10. Release the clutch pedal.**COLD WEATHER STARTING**

If the ambient temperature is below 0 °C and the engine is very cold, follow the procedure below after taking the step 1 through 5 in the previous pages.

6. Turn the key to "ON" position and hold it until the indicator turns off.

The indicator comes on when the key is turned to "ON" position and engine coolant temperature is below 0 °C, and goes off automatically when preheat is completed.

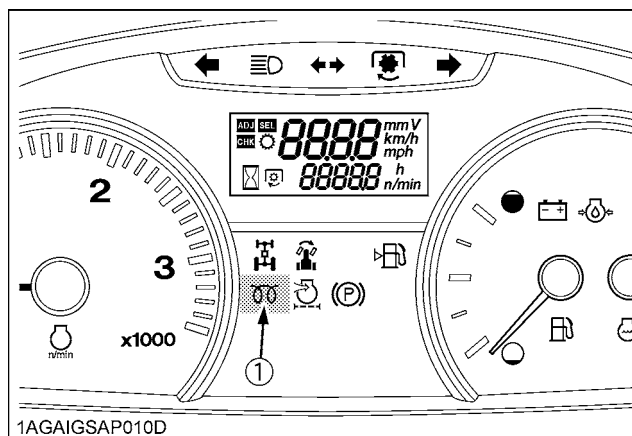

(1) Heater indicator

7. Fully depress the clutch pedal.**8. Turn the key to the "START" position and the engine should start.**

(If the engine fails to start after 10 seconds, turn off the key for 30 seconds. Then repeat steps 6 through 8. To protect the battery and the starter, make sure that the starter is not continuously turned for more than 10 seconds.)

■Block Heater (if equipped)

A block heater is available as an option from your dealer. It will assist you in starting your tractor when the ambient temperature is below -20 °C.

STOPPING THE ENGINE

1. After slowing the engine to idle, wait 3 to 5 minutes for turbo to slow down and then turn the key to "OFF".
2. Remove the key.

NOTE :

- If key does not stop the engine, consult your local KUBOTA Dealer.

WARMING UP



CAUTION

To avoid personal injury:

- Be sure to set the parking brake during warm-up.
- Be sure to set all shift levers to the "NEUTRAL" positions and to place PTO switch in "OFF" position during warm-up.

For five minutes after engine start-up, allow engine to warm up without applying any load, this is to allow oil to reach every engine part. If load should be applied to the engine without this warm-up period, trouble such as seizure, breakage or premature wear may develop.

■ Warm-up and Transmission Oil at Low Temperature Range

Hydraulic oil serves as transmission fluid. In cold weather, the oil may be cold with increased viscosity. This can cause delayed oil circulation or abnormally low hydraulic pressure for some time after engine start-up. This in turn can result in trouble in the hydraulic system.

To prevent the above, observe the following instructions: Warm up the engine at about 50 % of rated rpm according to the table below:

Ambient temperature	Warm-up time requirement
Higher than -10 °C	Approx. 10 minutes
-15 to -10 °C	10 to 20 minutes
-20 to -15 °C	20 to 30 minutes
Below -20 °C	More than 30 minutes

IMPORTANT :

- Do not operate the tractor under full load condition until it is sufficiently warmed up.

JUMP STARTING



CAUTION

To avoid personal injury:

- Battery gases can explode. Keep cigarettes, sparks, and flames away from battery.
- If tractor battery is frozen, do not jump start engine.
- Do not connect other end of negative (-) jumper cable to negative (-) terminal of tractor battery.

When jump starting engine, follow the instructions below to safely start the engine.

1. Bring helper vehicle with a battery of the same voltage as disabled tractor within easy cable reach. "THE VEHICLES MUST NOT TOUCH".
2. Engage the parking brakes of both vehicles and put the shift levers in neutral. Shut both engines off.
3. Put on safety goggles and rubber gloves.
4. Ensure the vent caps are securely in place. (if equipped)
5. Cover vent holes with damp rags. Do not allow the rag to touch the battery terminals.
6. Attach the red clamp to the positive (red, (+) or pos.) terminal of the dead battery and clamp the other end of the same cable to the positive (red, (+) or pos.) terminal of the helper battery.
7. Clamp the other cable to the negative (black, (-) or neg.) terminal of the helper battery.
8. Clamp the other end to the engine block or frame of the disabled tractor as far from the dead battery as possible.
9. Start the helper vehicle and let its engine run for a few moments. Start the disabled tractor.
10. Disconnect the jumper cables in the exact reverse order of attachment. (Steps 8, 7 and 6).
11. Remove and discard the damp rags.

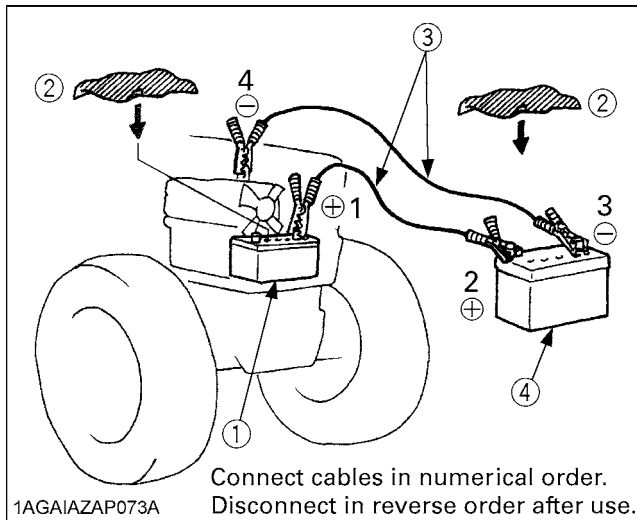

- (1) Dead battery
- (2) Lay a damp rag over the vent caps
- (3) Jumper cables
- (4) Helper battery

IMPORTANT :

- This machine has a 12 volt negative (-) ground starting system.
- Use only same voltage for jump starting.
- Use of a higher voltage source on tractor's electrical system could result in severe damage to tractor's electrical system.
Use only matching voltage source when "Jump starting" a low or dead battery condition.
- Do not operate the tractor with the battery cable disconnected from the battery.
- Do not operate the tractor without the battery mounted.
- Do not operate the tractor with the battery dead.
Charge the battery fully enough before operating the tractor.
Otherwise the tractor might malfunction.

OPERATING THE TRACTOR

OPERATING NEW TRACTOR

How a new tractor is handled and maintained determines the life of the tractor.

A new tractor just off the factory production line has been, of course, tested, but the various parts are not accustomed to each other, so care should be taken to operate the tractor for the first 50 hours at a slower speed and avoid excessive work or operation until the various parts become "broken-in". The manner in which the tractor is handled during the "breaking-in" period greatly affects the life of your tractor.

Therefore, to obtain the maximum performance and the longest life of the tractor, it is very important to properly break-in your tractor. In handling a new tractor, the following precautions should be observed.

■ Do not Operate the Tractor at Full Speed for the First 50 Hours.

- Do not start quickly nor apply the brakes suddenly.
- In winter, operate the tractor after fully warming up the engine.
- Do not run the engine at speeds faster than necessary.
- On rough roads, slow down to suitable speeds. Do not operate the tractor at fast speed.

The above precautions are not limited only to new tractors, but to all tractors. But it should be especially observed in the case of new tractors.

■ Changing Lubricating Oil for New Tractors

The lubricating oil is especially important in the case of a new tractor. The various parts are not "broken-in" and are not accustomed to each other; small metal grit may develop during the operation of the tractor; and this may wear out or damage the parts. Therefore, care should be taken to change the lubricating oil a little earlier than would ordinarily be required.

For further details of change interval hours.

(See "MAINTENANCE" section.)

OPERATING FOLDABLE ROPS



CAUTION

To avoid personal injury:

- When raising or folding the ROPS, apply parking brake, stop the engine and remove the key.

Always perform function from a stable position.

- Fold the ROPS down only when absolutely necessary and fold it up and lock it again as soon as possible.

- Before proceeding to fold ROPS, check for any possible interference with installed implements and attachments.

If interference occurs, contact your KUBOTA Dealer.

■ To Fold the ROPS

1. Remove both lock pins.

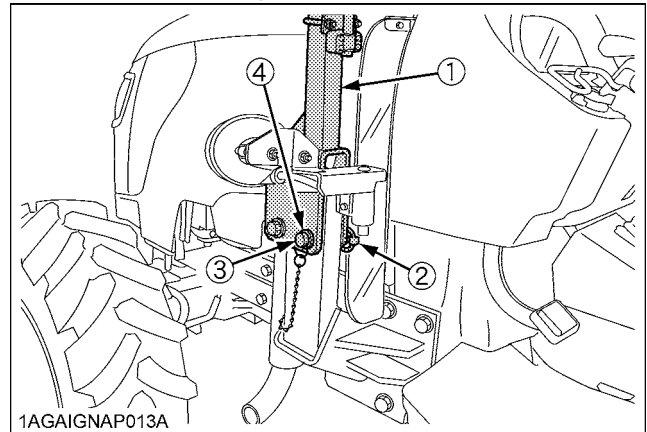

- (1) ROPS
- (2) Lynch pin
- (3) Lock pin
- (4) Cushion

2. Fold the ROPS.



CAUTION

To avoid personal injury:

- Hold the ROPS tightly with both hands and fold the ROPS slowly and carefully.

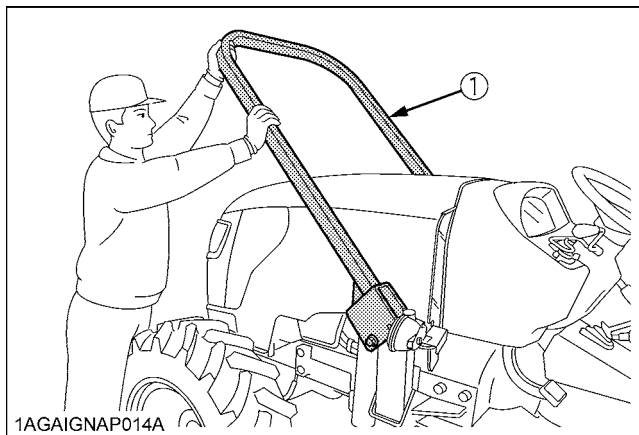

(1) ROPS

3. Reinstall lock pins with cushions and lynch pins into holes in ROPS frame to lock.



CAUTION

To avoid personal injury:

- Make sure that both lock pins are properly installed and secured with lynch pins.

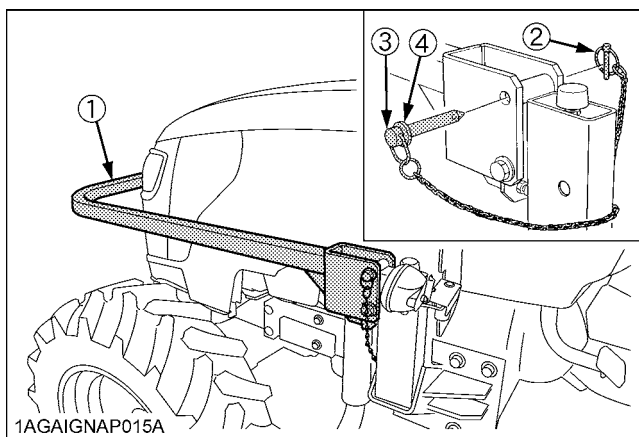

(1) ROPS
(2) Lynch pin
(3) Lock pin
(4) Cushion

To Raise the ROPS to Upright Position

1. Remove both lynch pins and lock pins.

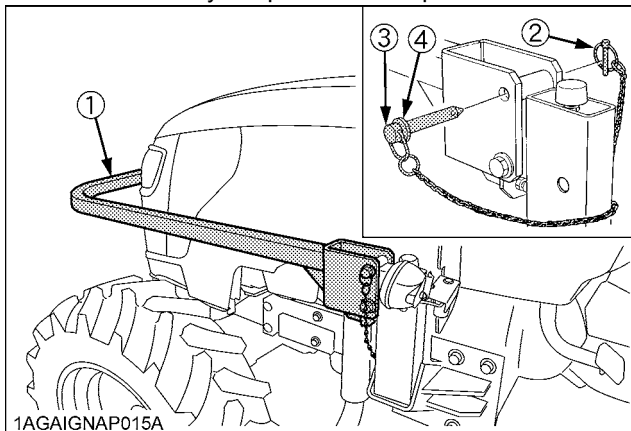

(1) ROPS
(2) Lynch pin
(3) Lock pin
(4) Cushion

2. Raise ROPS to the upright position.



CAUTION

To avoid personal injury:

- Raise the ROPS slowly and carefully.

3. Align lock pin holes, insert both lock pins with cushions and secure them with lynch pins.



CAUTION

To avoid personal injury:

- Make sure that both lock pins are properly installed as soon as the ROPS is in the upright position and secured with lynch pins.

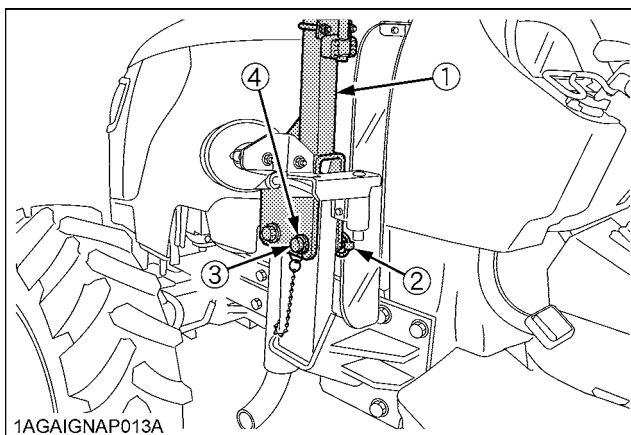

(1) ROPS
(2) Lynch pin
(3) Lock pin
(4) Cushion

STARTING

1. Adjusting the Operator's Position.

■ Operator's Seat

⚠ CAUTION

To avoid personal injury:

- Make adjustments to the seat only while the tractor is stopped.
- Make sure that the seat is completely secured after each adjustment.
- Do not allow any person other than the operator to ride on the tractor.

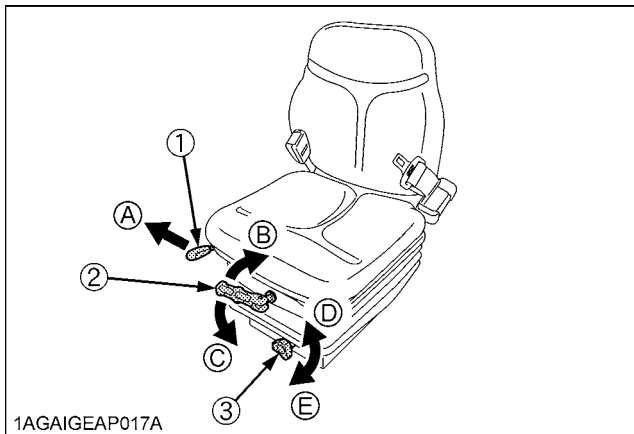

- | | |
|-----------------------------|---------------------------|
| (1) Travel adjust lever | (A) "UNLOCK" |
| (2) Suspension adjust lever | (B) "TO INCREASE TENSION" |
| (3) Height adjust knob | (C) "TO DECREASE TENSION" |
| | (D) "HIGH" |
| | (E) "LOW" |

◆ Travel adjustment

Unlock the travel adjust lever and slide the seat backward or forward, as required. The seat will lock in position when the lever is released.

◆ Suspension adjustment

Turn the suspension adjust lever to achieve the optimum suspension setting.

◆ Height adjustment

Turn the height adjust knob to desired position while sitting in the seat.

IMPORTANT :

- After adjusting the operator's seat, be sure to check to see that the seat is properly locked,

■ Seat Belt

⚠ WARNING

To avoid personal injury:

- Always use the seat belt when any ROPS or CAB are installed.
- Do not use the seat belt if a foldable ROPS or a retractable ROPS is down or there is no ROPS.

Adjust the seat belt for proper fit and connect the buckle. This seat belt is auto-locking retractable type.

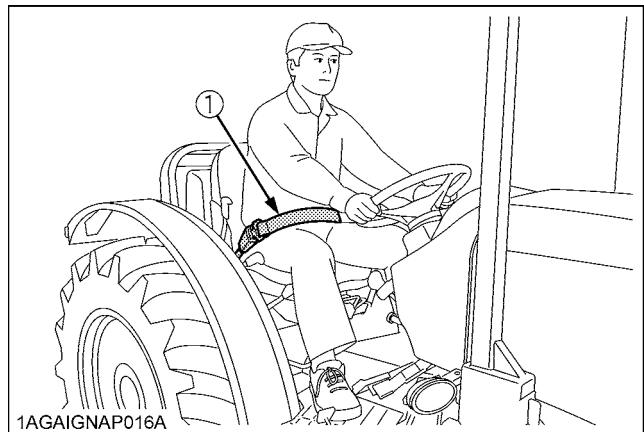

(1) Seat belt

■ Muffler

⚠ CAUTION

To avoid personal injury:

- Do not touch the muffler pipe or muffler while the engine is running or while muffler pipes are hot.
The high temperature will cause burning.
- Remove all weeds, straw, and combustible material from the muffler pipe, muffler and exhaust manifold to prevent fires.

If necessary, loosen the nut and adjust the muffler pipe to the proper direction for the work.

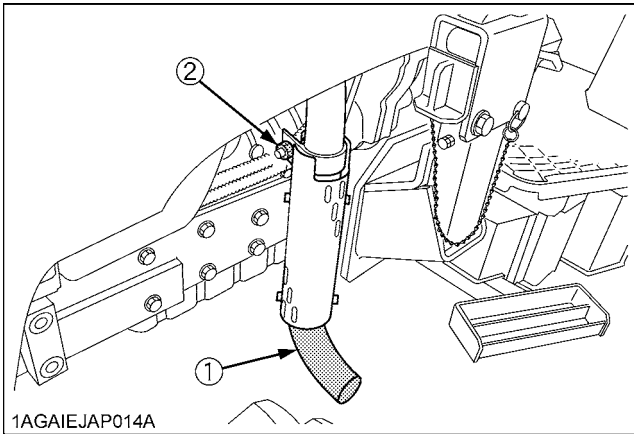

1AGAIEJAP014A

- (1) Muffler pipe
- (2) Nut (M10): 48.1 to 55.8 N-m (4.9 to 5.7 kgf-m)

■ Tilt Steering Adjustment



CAUTION

To avoid personal injury:

- Do not adjust the steering wheel while the tractor is in motion.

Steering wheel is adjustable when tilt lever is unlocked.

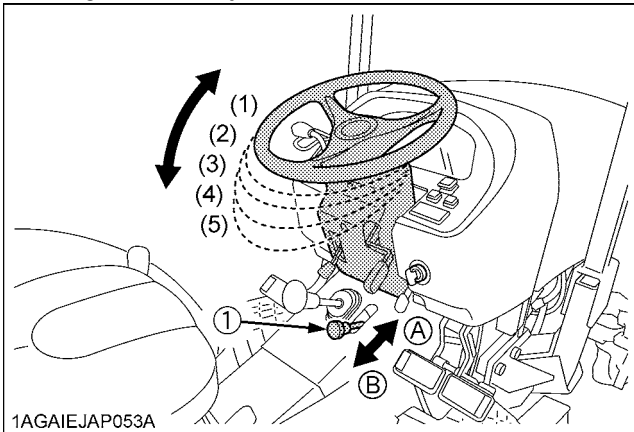

1AGAIEJAP053A

(1) Tilt lever

(A) "UNLOCK"
(B) "LOCK"

2. Selecting Light Switch Positions.

■ Light Switch

Turn the light switch clockwise, and the following lights are activated on the switch position.

- Head lights OFF.
- ☾ Head lights dimmed, low beam.
- ☼ Head lights ON, high beam.

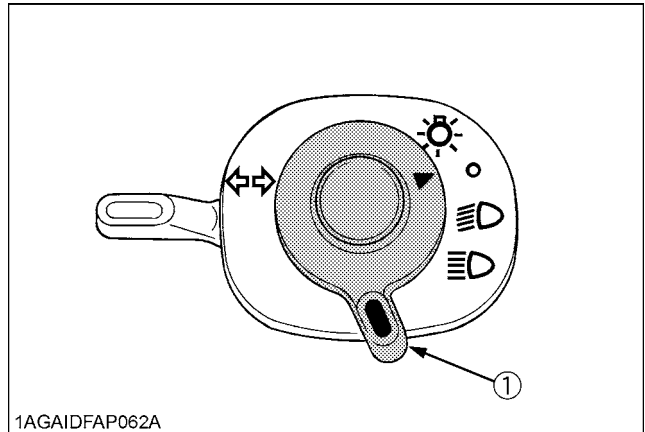

1AGAIDFAP062A

(1) Head light switch

■ Turn Signal / Hazard Light Switch

◆ Hazard Light

1. When the hazard light switch is pushed, the hazard lights flash, along with the L/H and R/H indicators on the instrument panel.
2. Push the hazard light switch again to turn off the hazard lights.

◆ Turn signal light

To indicate a right turn, turn the turn signal light switch clockwise. To indicate a left turn, turn the turn signal light switch counter-clockwise. The corresponding right and left turn signal lights and indicator on the instrument panel will flash.

NOTE :

- The hazard light switch is operative when the key switch is in either the "ON" or "OFF" position.
- The turn signal light switch is only operative when the key switch is in the "ON" position.
- Be sure to return the turn signal switch to center position after turning.

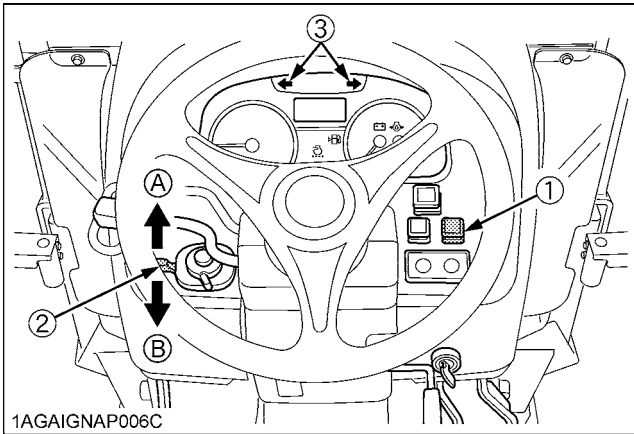

1AGAIGNAP006C
 (1)Hazard light switch (A) "RIGHT TURN"
 (2)Turn signal light switch (B) "LEFT TURN"
 (3)Hazard / Turn signal indicator

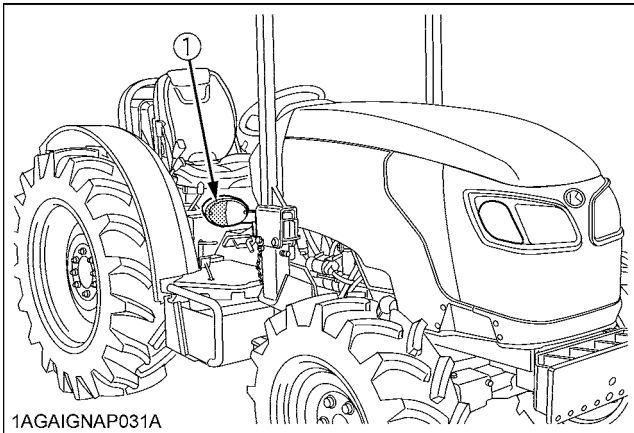

1AGAIGNAP031A

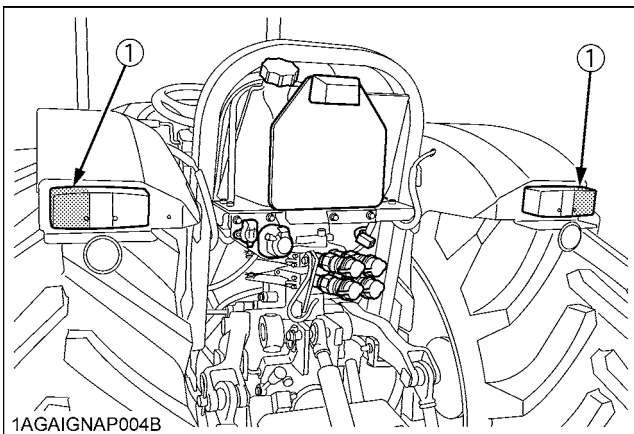

1AGAIGNAP004B
 (1) Turn signal / Hazard light

Front Turn Signal / Hazard Light

If necessary, raise and turn the light stay to the rearward for the work.

Return the light stay to the original position when traveling on a road.

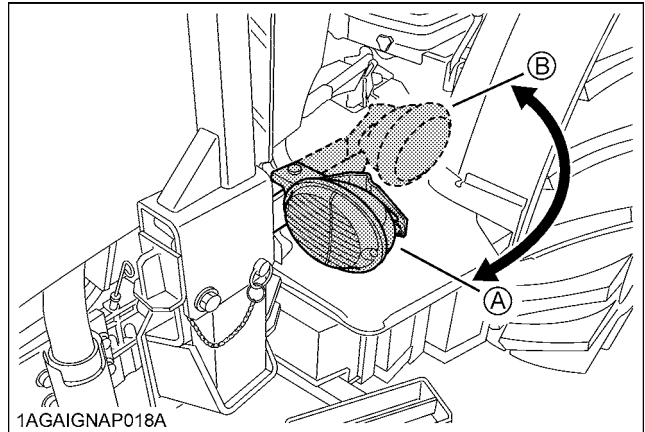

1AGAIGNAP018A

(A) "ORIGINAL POSITION"
 (B) "WORK POSITION"

With Trailer Connector

When you operate the turn signal light switch with the trailer power connector connected, the trailer indicator in the instrumental panel also starts flashing along with the turn signal indicator.

Horn Button

The horn will sound when the key switch is "ON" position and horn button is pushed.

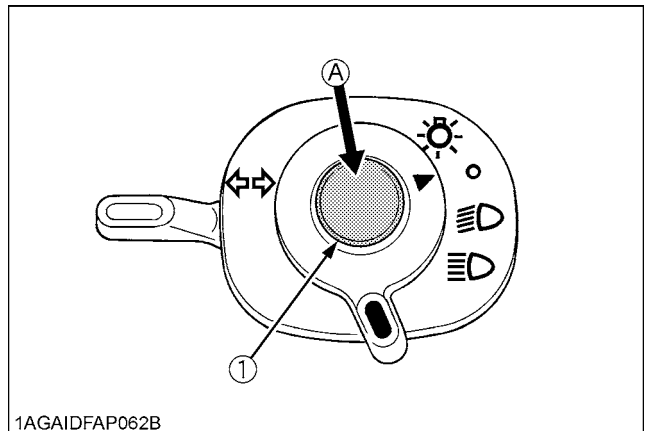

1AGAIDFAP062B

(1) Horn button (A) "PUSH"

Front Work Light Switch

CAUTION

To avoid personal injury:

- Do not operate on roads with work lights on. Work lights may blind or confuse operators of oncoming vehicles.

Turn on the key switch and press the front work light switch. The work lights and the switch's indicator light up. Press the switch to turn off the light and indicator.

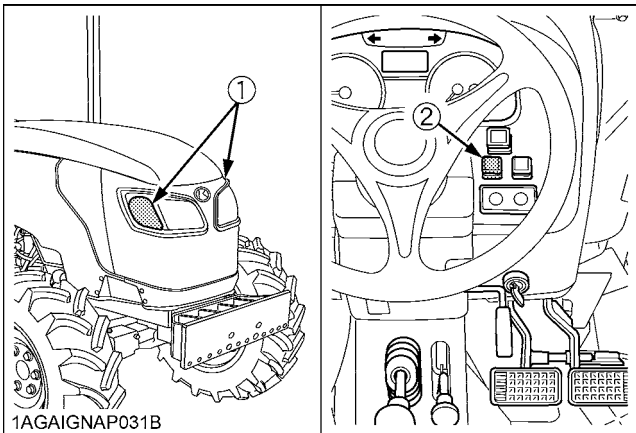

(1) Front work light
(2) Front work light switch with indicator

3. Checking the Brake Pedal.

Brake Pedals (Right and Left)

WARNING

To avoid personal injury:

- Be sure to interlock the right and left pedals. Applying only one rear wheel brake at high speeds could cause the tractor to swerve or roll-over.
- Be sure brake pedals have equal adjustment when using locked together. Incorrect or unequal brake pedal adjustment can cause the tractor to swerve or roll-over.

CAUTION

To avoid personal injury:

- Be aware of the enhanced braking characteristics of 4 wheel braking system. Appropriate care should be taken during hard braking and/or when pulling towed loads.

- Do not make sudden braking. An accident may occur such as by heavy towed load shifting forward or loss of control.
- To avoid skidding and loss of steering control when driving on icy, wet, or loose surfaces, make sure the tractor is correctly ballasted, operated at reduced speed, operated with front wheel drive engaged (If equipped).
- The braking characteristics are different between two and four wheel drive. Be aware of the difference and use carefully.

1. Before operating the tractor on the road, be sure to interlock the right and left pedals as illustrated below.
2. Use individual brakes to assist in making sharp turns at slow speeds (Field Operation Only). Disengage the brake pedal lock and depress only one brake pedal.
3. Be sure brake pedals have equal adjustment when being used locked together.

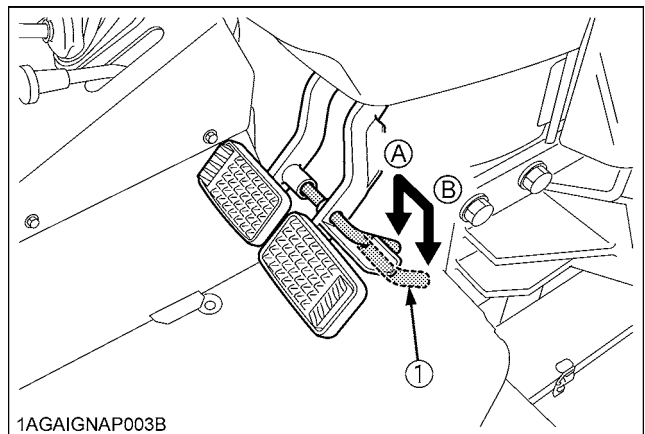

(1) Brake pedal lock (A) "LOCK" (B) "RELEASE"

4WD Braking System [4WD model]

4WD model tractor is equipped with 4WD braking system. When both brake pedals are applied together, the front axle is engaged for four wheel braking regardless of the mode selected at the 4WD switch. When you step on the brake pedal while driving in 2WD mode, the "4WD braking system" gets activated and the 4WD indicator lights up.

WARNING

To avoid the possibility of personal injury or property damage from machine runaway during testing, service or repair with the rear wheels off the ground, make sure:

- Battery is disconnected and engine is not started.
- If it is necessary to run the engine, make sure:
- Both front and rear wheels are off the ground and secured with stands before starting engine.

4. Raise the Implement.
(see "HYDRAULIC UNIT" section.)

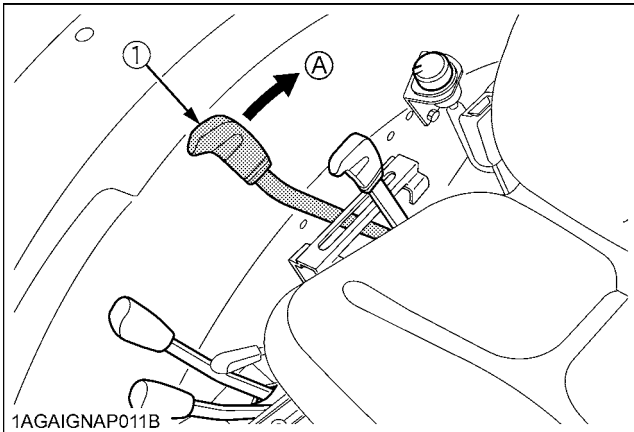

(1) Position control lever (A) "UP"

5. Depress the Clutch Pedal.

■ Clutch Pedal



CAUTION

To avoid personal injury:

- Sudden release of the clutch may cause the tractor to lunge in an unexpected manner.

The clutch is disengaged when the clutch pedal is fully pressed down.

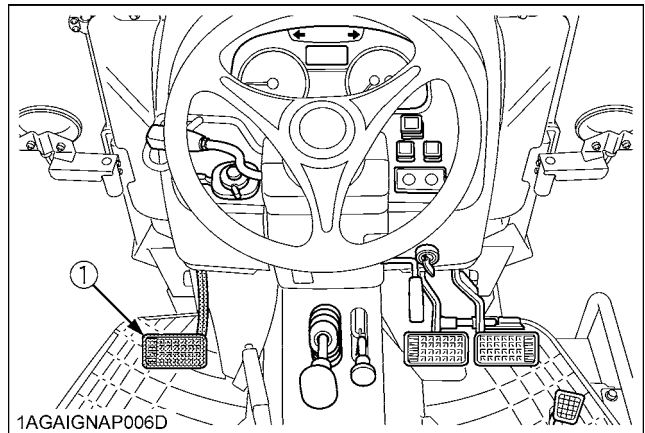

(1) Clutch pedal

IMPORTANT :

To help prevent premature clutch wear:

- The clutch pedal must be quickly disengaged and be slowly engaged.
- Avoid operating the tractor with your foot resting on the clutch pedal.
- Select proper gear and engine speed depending on the type of job.

6. Selecting the Travel Speed.

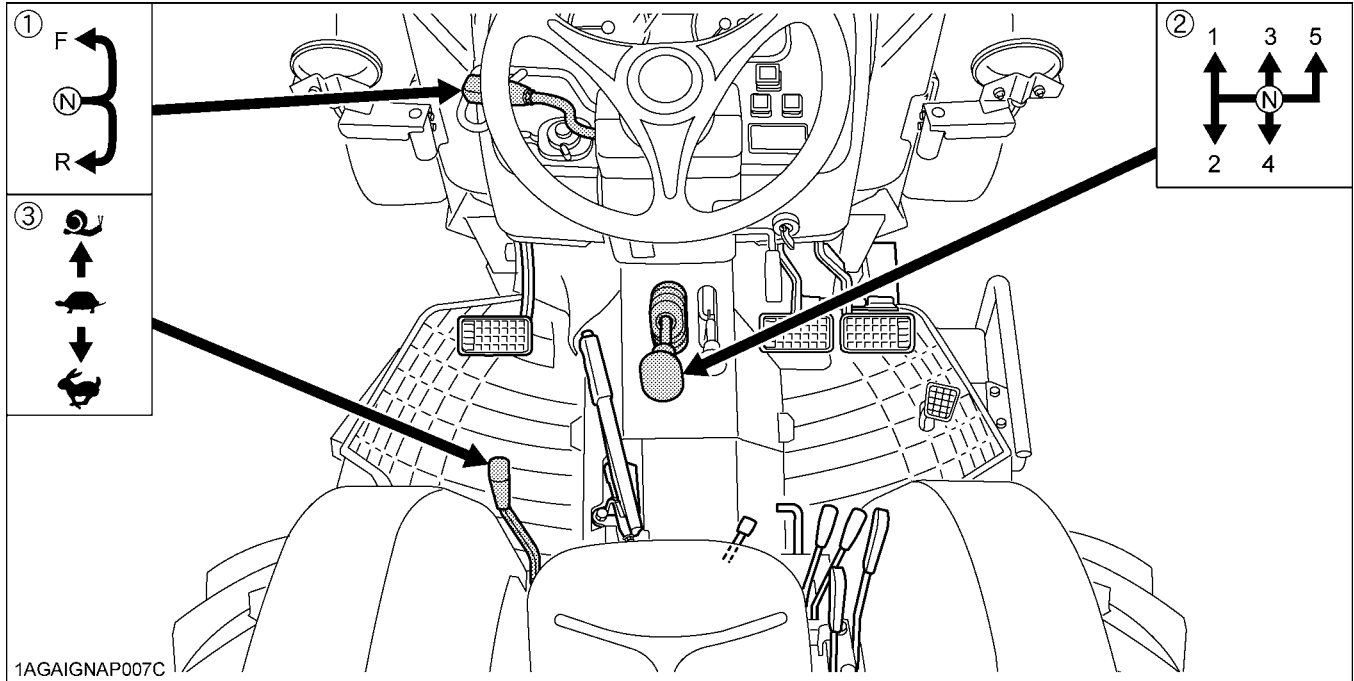

- (1) Hydraulic - shuttle shift lever
- (2) Main gear shift lever
- (3) Range gear shift lever

- (F) "FORWARD"
- (N) "NEUTRAL POSITION"
- (R) "REVERSE"

- ☰ "LOW"
- ☶ "HIGH"
- 🌀 "CREEP"

By combination of using the main gear shift lever, the range gear shift lever and hydraulic-shuttle shift lever, forward speeds and reverse speeds shown in the table below are obtained.

Standard model	15 forward speeds 15 reverse speeds
----------------	--

■ Main Gear Shift Lever

The main gear shift is fully synchronized to shift without stopping.

IMPORTANT :

- The main gear shift may be shifted between speeds on-the-go, but the clutch must be depressed.

■ Range Gear Shift Lever

The range gear shift can only be shifted when the tractor is completely stopped and the clutch is depressed.

IMPORTANT :

- To avoid transmission damage, depress clutch pedal and stop the tractor before shifting between ranges.

■ Hydraulic-Shuttle Shift Lever

Raise up and shift the shuttle shift lever forward to obtain forward speeds and shift back to obtain reverse speeds. This shifting does not require clutch operation.

IMPORTANT :

- The hydraulic-shuttle shift lever may be shifted while the tractor is moving slowly.

■ Creep Speed

Shift the range gear shift lever to  to obtain low speeds.

This shifting requires clutch operation.

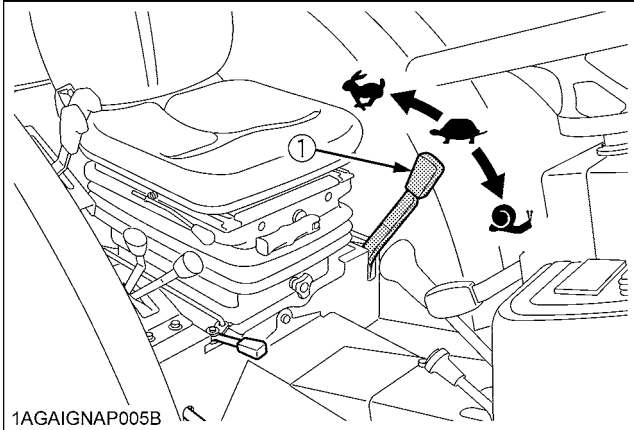

1AGAIGNAP005B

(1) Range gear shift lever  ...Creep ON

◆ Creep speed should be used only when doing one of the following jobs:

1. Deep rotary-tilling and harrowing
2. Planting
3. Turf application

◆ Creep speed can not be used for any of the followings:

1. Pulling a trailer
2. Front-loader operation
3. Front-blade operation
4. Earth-moving
5. Entering and leaving a field
6. Loading onto and unloading from a truck



CAUTION

To avoid personal injury:

- When you leave the tractor, be sure to apply the parking brake and stop the engine.
- IN APPLYING THE BRAKES:
 - The torque of the wheel axle is extremely high while creep speed is being used. Be sure to step down on the clutch pedal completely before applying the brakes, or they will not work
 - When starting to operate the tractor, be sure to release the parking brakes.
Misuse of the brakes may cause damage to the transmission and is therefore not acceptable to KUBOTA for coverage under the warranty.

IMPORTANT :

- Press the clutch pedal completely down and stop the tractor's motion before shifting the range gear shift lever.

■ 4WD / Bi-speed Turn Switch



CAUTION

To avoid personal injury:

- Do not engage the front wheel drive when traveling at road speed.
- When driving on icy, wet, or loose surfaces, make sure the tractor is correctly ballasted to avoid skidding and loss of steering control. Operate at reduced speed and engage front wheel drive.
- 4WD model tractor is equipped with 4 wheel braking and appropriate care should be taken during hard braking.
- An accident may occur if the tractor is suddenly braked, such as by heavy towed loads shifting forward or loss of control.
- The braking characteristics are different between two and four wheel drive tractor models. Be aware of the difference and use carefully.
- Do not use "Bi-speed Turn" at high speed.
- "Bi-speed Turn" enables short and fast turns, therefore, become familiar with its performance before operating in close or confined areas.

When this switch is pressed;

The front wheel drive (4WD) is engaged.

The 4WD indicator comes on when the system is in 4WD mode.

Press the switch again;

The Bi-speed turn system activates.

The indicator within the switch and 4WD indicator and Bi-speed turn indicator come on when the system is in Bi-speed turn mode.

Press the switch one more time;

The drive system returns to 2WD mode.

All the indicators go off when the system is in 2WD mode. (While the brake pedal is stepped on or the parking brake is applied, however, the 4WD braking system is working and the 4WD indicator stays on.)

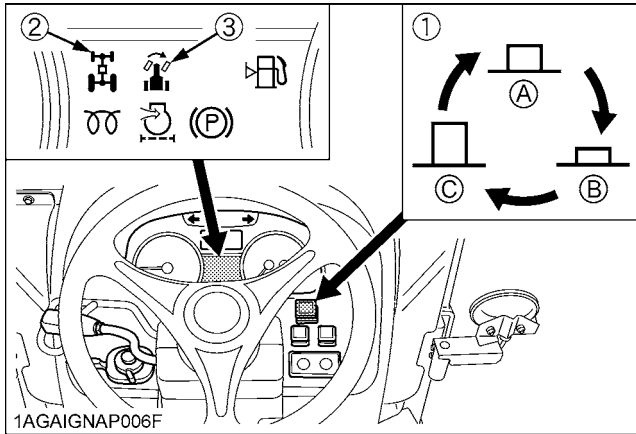

- (1) 4WD/Bi-speed Turn switch with indicator
- (2) 4WD indicator
- (3) Bi-speed turn indicator
- (A) 4WD "ON"
- (B) Bi-speed turn "ON"
- (C) 2WD (Switch "OFF")

NOTE :

- This switch can be operated when the tractor is on the go or at rest without depressing the clutch.
- Bi-speed turn system works when you press the "4WD/Bi-speed turn switch" twice from "2WD" mode (once from "4WD" mode) and the turning angle of the front tires has become large. Bi-speed turn makes the front tire speed about twice faster than the standard 4WD front tire speed.

◆ **Front wheel drive is effective for the following jobs:**

1. When greater pulling force is needed, such as working in a wet field, when pulling a trailer, disking or harrowing.
2. When working in sandy soil.
3. When working on a hard soil where a rotary tiller might push the tractor forward.
4. For increased braking at reduced speed.

◆ **Bi-speed turn use is effective for the following jobs:**

1. Turning at the end of rows. (planting, cultivating, harrowing.)
2. Increasing maneuverability when working in tight spaces.

IMPORTANT :

- Tires will wear quickly if the front wheel drive is engaged on paved roads.

7. Accelerate the Engine.

■ **Hand Throttle Lever**

Pushing the throttle lever down decreases engine speed, and pulling it upper increases engine speed.

■ **Foot Throttle**

Use the foot throttle when traveling on the road. Press down on it for higher speed. The foot throttle is interlocked with the hand throttle lever; when using the foot throttle, keep the hand throttle lever in low idling position.

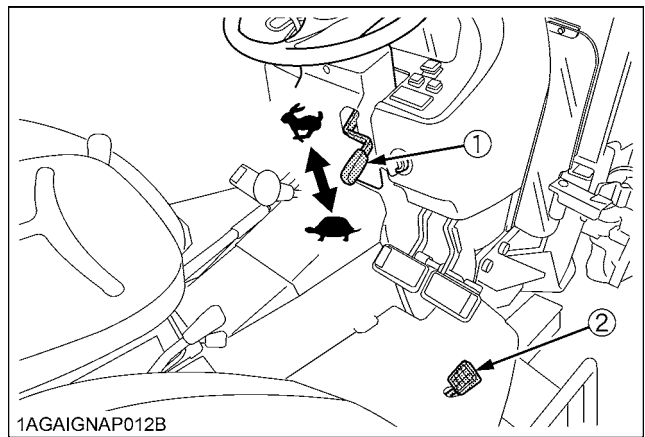

- (1) Hand throttle lever
- (2) Foot throttle
- ↑ "INCREASE"
- ↓ "DECREASE"

8. Unlock the Parking Brake and Slowly Release the Clutch.

■ Parking Brake Lever

To release the parking brake, depress the brake pedal, push the release button and push the parking brake lever down.

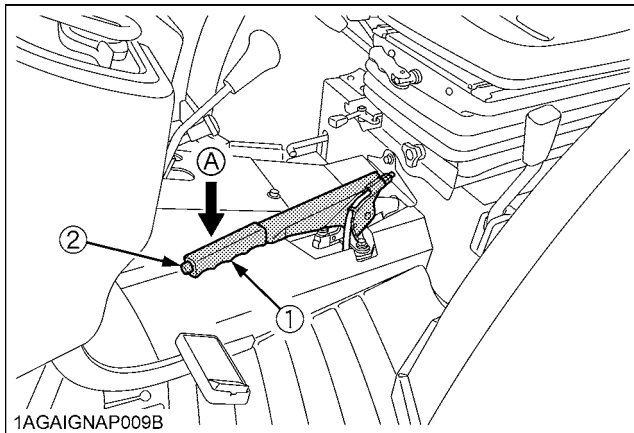

(1) Parking brake lever (A) "RELEASE"
(2) Release button

NOTE :

- The parking brake indicator light on the Easy Checker(TM) will turn off when the parking brake is unlocked.

IMPORTANT :

- Do not attempt to put the tractor in motion before the parking brake indicator light turns off.
- If the tractor is operated with the parking brake set, the parking brake might be damaged.

STOPPING

■ Stopping

1. Slow down the engine.
2. Step on the clutch and brake pedal.
3. After the tractor has stopped, disengage the PTO, lower the implement to the ground, shift the transmission to neutral, release the clutch pedal, and set the parking brake.

CHECK DURING DRIVING

■ Immediately Stop the Engine if:

- The engine suddenly slows down or accelerates,
- Unusual noises are suddenly heard,
- Exhaust fumes suddenly become very dark,

■ Easy Checker(TM)

If the warning lamps in the Easy Checker(TM) come on during operation, immediately stop the engine, and find the cause as shown below.

Never operate the tractor while Easy Checker(TM) lamp is on.

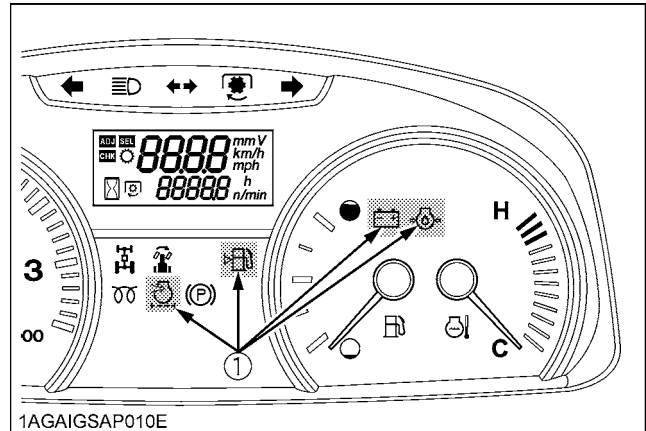

(1) Easy Checker(TM)

⊕ Engine oil pressure

If the oil pressure in the engine goes below the prescribed level, the warning lamp in the Easy Checker(TM) will come on.

If this should happen during operation, and it does not go off when the engine is accelerated to more than 1000 rpm, check level of engine oil.

(See "Checking Engine Oil Level" in "DAILY CHECK" in "PERIODIC SERVICE" section.)

⊕ Fuel level

If the fuel in the tank goes below the prescribed level, the warning lamp in the Easy Checker(TM) will come on. (less than 11 L)

If this should happen during operation, refuel as soon as possible.

(See "Checking and Refueling" in "DAILY CHECK" in "PERIODIC SERVICE" section.)

⊕ Air cleaner

If the air cleaner is clogged, the warning lamp in the Easy Checker(TM) will come on.

If this should happen during operation, clean the air cleaner element.

(See "Cleaning Air Cleaner Primary Element" in "EVERY 100 HOURS" in "PERIODIC SERVICE" section.)



Electrical charge

If the alternator is not charging the battery, the Easy Checker(TM) will come on.

If this should happen during operation, check the electrical charging system or consult your local KUBOTA Dealer.

NOTE :

- For checking and servicing of your tractor, consult your local KUBOTA Dealer for instructions.

Fuel Gauge

When the key switch is on, the fuel gauge indicates the fuel level.

Be careful not to empty the fuel tank. Otherwise air may enter the fuel system.

Should this happen, the system should be bled (See "Bleeding Fuel System" in "SERVICE AS REQUIRED" in "PERIODIC SERVICE" section.)

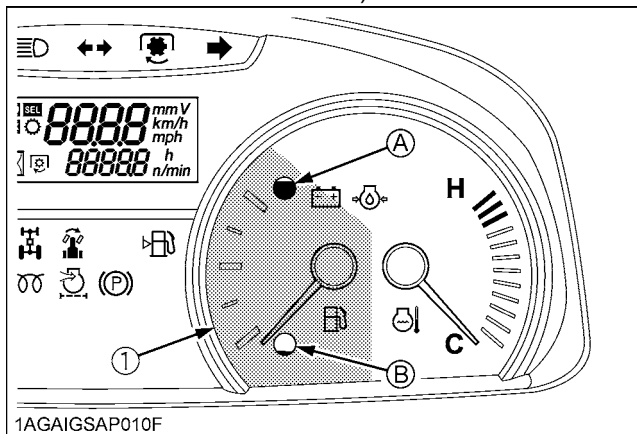

(1) Fuel gauge

(A) "FULL"
(B) "EMPTY"

Coolant Temperature Gauge



CAUTION

To avoid personal injury:

- Do not remove radiator cap until coolant temperature is well below its boiling point. Then loosen cap slightly to the stop to relieve any pressure before removing cap completely.

1. With the key switch at "ON", this gauge indicates the temperature of the coolant. "C" for "cold" and "H" for "hot."
2. If the indicator reaches the "H" position (red zone), engine coolant is overheated. Check the tractor by referring to "TROUBLESHOOTING" section.

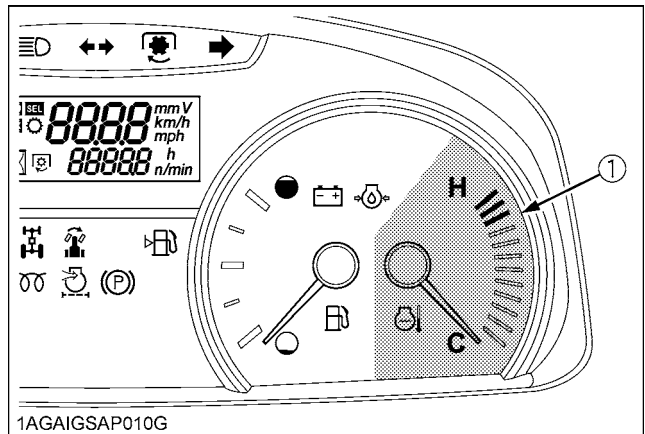

(1) Coolant temperature gauge

Tachometer

The tachometer indicates the engine speed on the dial.

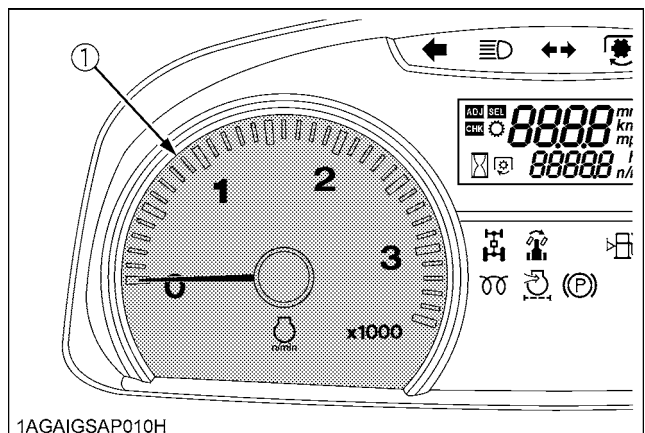

(1) Engine revolution





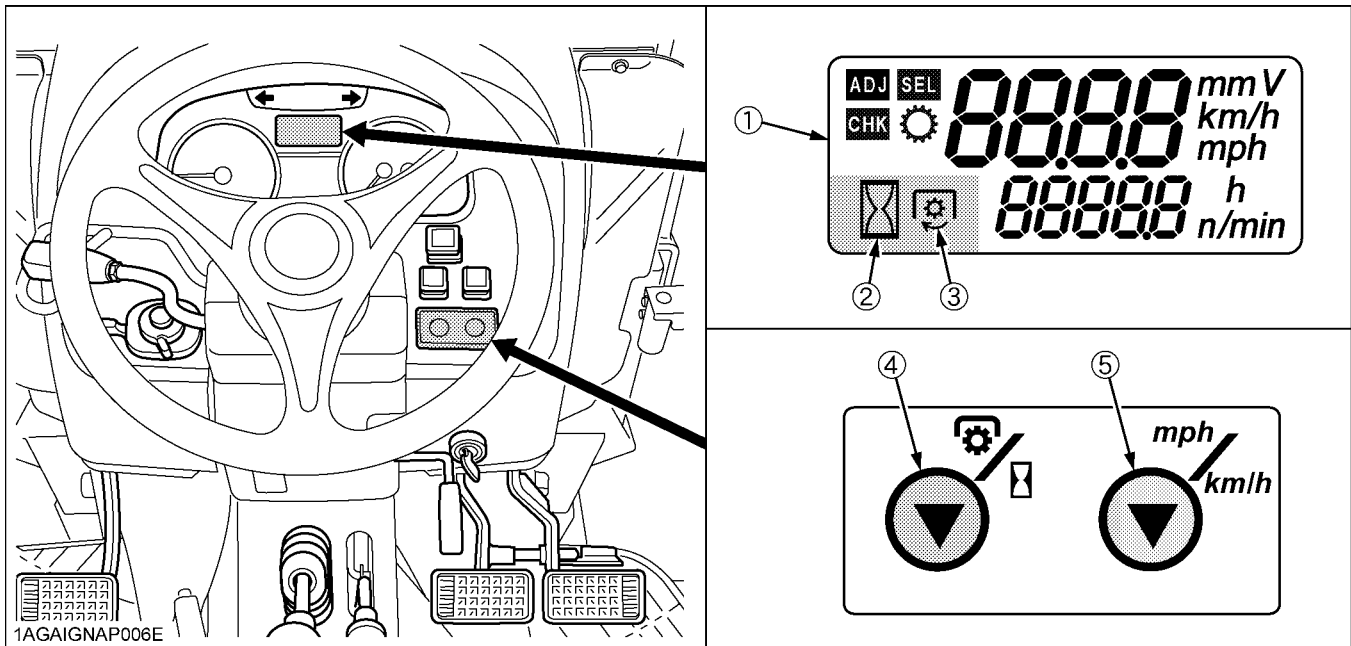

PTO RPM / TRAVEL SPEED MONITOR

■ Changing Display Mode

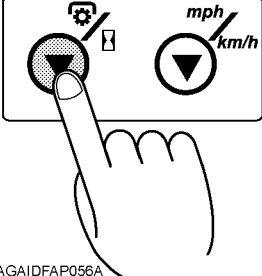
1. The LCD monitor gives two different display modes: "Traveling speed and Hour meter" and "Traveling speed and PTO speed". Each time the PTO/Hour meter select switch is pressed, the mode is switched to the changing display.
2. To switch between "mph" and "km/h" for the traveling speed, use the Traveling speed select switch.
3. The PTO clutch control switch works for the following automatic display modes.
 - 1) PTO clutch control switch ON: Traveling speed and PTO speed are displayed.
 - 2) PTO clutch control switch OFF: Traveling speed and Hour meter are displayed.

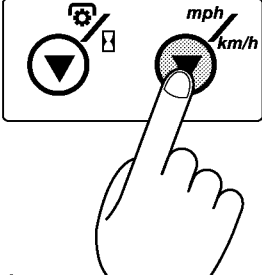

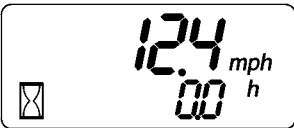
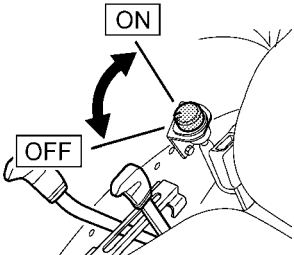
- (1) LCD monitor
- (2) Hour Meter indication
- (3) PTO Indication
- (4) PTO / Hour Meter Select Switch
- (5) Traveling Speed Select Switch

<p>1</p>	<p>Display mode switching [Hour meter mode] and [PTO speed mode]</p>  <p>1AGAIDFAP056A</p>	<p>Hour meter mode</p>  <p>1AGAIDFAP072H</p>	<ul style="list-style-type: none"> ● Traveling speed and total operating hours are displayed. ● The hour meter indicates in five digits the hours the tractor has been used; the last digit indicates 1/10 of an hour.
		<p>PTO speed mode</p>  <p>1AGAIDFAP072I</p>	<ul style="list-style-type: none"> ● Traveling speed and PTO speed are displayed. ● When the PTO clutch control switch is in "OFF" position, "OFF" is displayed. ● See "PTO Speed Display Mode Switching" in "PTO RPM / TRAVEL SPEED MONITOR" in "OPERATING THE TRACTOR" section.
<p>2</p>	<p>Display mode switching [km/h] and [mph]</p>  <p>1AGAIDFAP056B</p>	<p>km/h (Traveling speed)</p>  <p>1AGAIDFAP072C</p>	
		<p>mph (Traveling speed)</p>  <p>1AGAIDFAP072D</p>	
<p>3</p>	<p>PTO clutch control switch</p>  <p>1AGAIGNAP011C</p>	<p>PTO OFF (Hour meter mode)</p>  <p>1AGAIDFAP072H</p>	<ul style="list-style-type: none"> ● Traveling speed and total operating hours are displayed. ● The hour meter indicates in five digits the hours the tractor has been used; the last digit indicates 1/10 of an hour. ● When the PTO / Hour meter select switch is pressed in this state, "OFF" is displayed.
		<p>PTO ON (PTO speed mode)</p>  <p>1AGAIDFAP072I</p>	<ul style="list-style-type: none"> ● Traveling speed and PTO speed are displayed. ● When the PTO / Hour meter select switch is pressed in this state, the display mode switches to hour meter mode.

NOTE :

- The travel speed displayed when the wheels slip under traction is different from the actual one.
- In cold weather the LCD monitor response will normally be slower and the visibility be less, than in warmer weather.

■ PTO Speed Display Mode Switching

[with 540/540E rpm model]

The PTO speed display mode has been factory-set at Code 1. Do not attempt to change the code. Otherwise the correct PTO speed will not be displayed in the LCD monitor.

(NOTE: The current code can be checked in the following procedure.)

◆ Switching procedure

- ① While pressing the PTO/Hour meter select switch, turn the key switch to "ON" position.

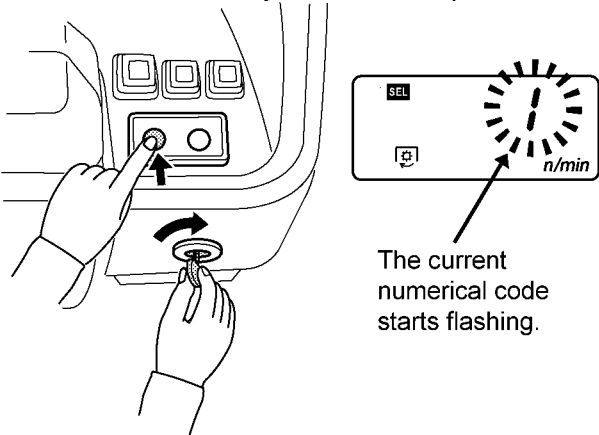

- ② Each time the PTO/Hour meter select switch is pressed, the code changes in the order of [1]→[2]→[1]. Select the appropriate code according to the table below.

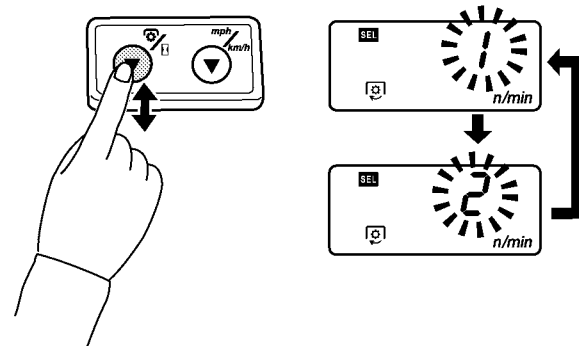

- ③ Press and hold the PTO/Hour meter select switch longer than 2 seconds. The setting is put in memory, and the LCD monitor goes back to the PTO speed display mode.

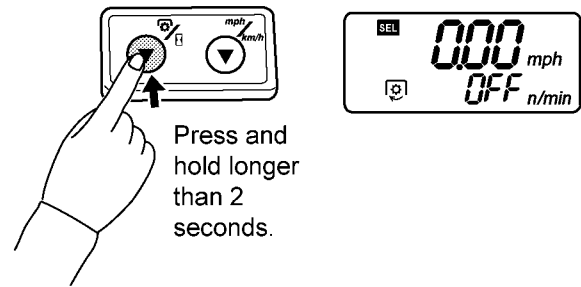

NOTE:

- The setting will be cancelled if the key switch is turned OFF halfway in the procedure.

Numerical code	PTO speed (rpm)
1	540 / 540E (Standard)
2	Not select

■ Entering the Travel Speed Coefficient

When optional different-diameter tires are fitted on the machine, the travel speed display mode must be changed. Otherwise the travel speed will not get correctly displayed. Such mode switching is also needed when the original tires are back on the machine.

◆ How to enter the tire circumference

Example: Entering 4455 mm.

- While pressing the Traveling speed select switch, turn the key switch to ON position. The setting of the current tire's circumference is displayed in inches or millimeters. The highest-digit numeral starts flashing.

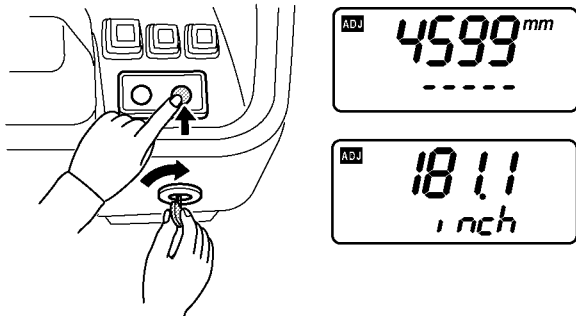

- Each time both the PTO/Hour meter select switch and Traveling speed select switch are pressed at the same time, the unit changes for inches or millimeters. Select the inch display mode.

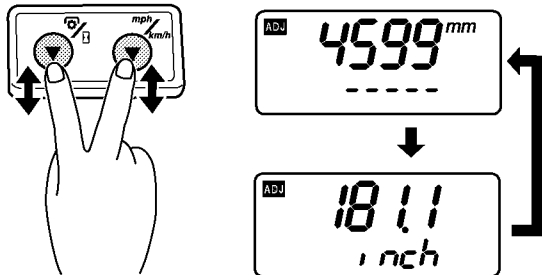

- Note that the highest-digit numeral is flashing. Press the PTO/Hour meter select switch to select "4". (The numeral changes from 0 to 9 at each push of the switch.)

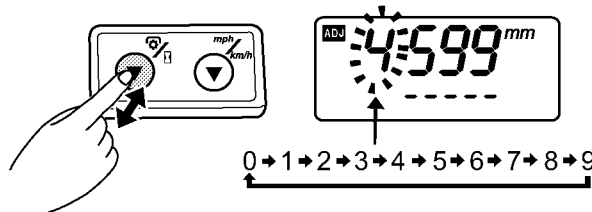

- Press the Traveling speed select switch, and the next highest digit starts flashing.

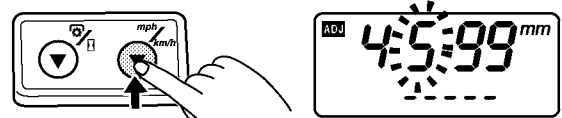

Now press the PTO/Hour meter select switch to select "4".

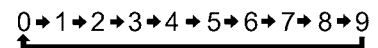
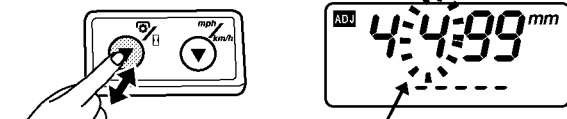

- Enter "5" and "5" for the remaining digits in the same procedure.
- Make sure the entry is "4455". Press and hold the Traveling speed select switch longer than 2 seconds. The setting is put in memory, and the LCD monitor goes back to the Hour meter mode.

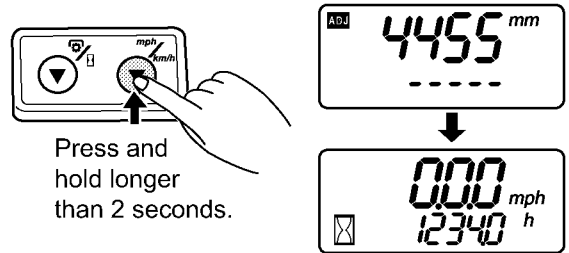

NOTE:

- The setting will be cancelled if the key switch is turned OFF halfway in the procedure.

◆ Tire circumference chart

Rear tire size	Entry (mm)
420/70R24	3715
380/70R28	4059

PARKING

■ Parking



CAUTION

To avoid personal injury:
BEFORE DISMOUNTING TRACTOR

- ALWAYS SET PARKING BRAKE AND LOWER ALL IMPLEMENTS TO THE GROUND.
Leaving transmission in gear with the engine stopped will not prevent the tractor from accidental rolling.
- STOP THE ENGINE AND REMOVE THE KEY.

1. Before getting off the tractor, disengage the PTO, lower all implements, place all control levers in their neutral positions, pull the parking brake lever up to park, stop the engine and remove the key.
2. If it is necessary to park on an incline, be sure to chock the wheels to prevent accidental rolling of the machine.

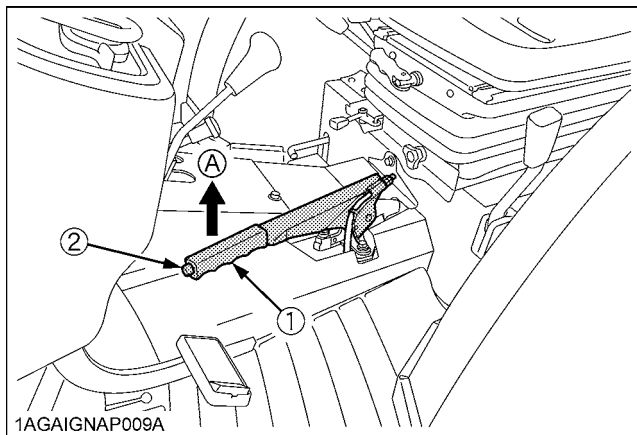

(1) Parking brake lever
(2) Release button

(A) "PULL"

OPERATING TECHNIQUES

■ Differential Lock



WARNING

To avoid personal injury due to loss of steering control:

- Do not operate the tractor at high speed with differential lock engaged.
- Do not attempt to turn with the differential lock engaged.
- Be sure to release the differential lock before making a turn in field conditions.

If one of the rear wheels should slip, step on the differential lock pedal. Both wheels will turn together, then reduce slippage.

Differential lock is maintained only while the pedal is depressed.

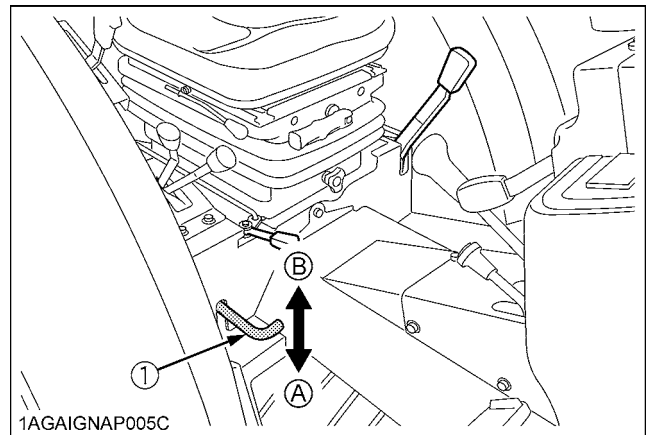

(1) Differential lock pedal

(A) Press to "ENGAGE"

(B) Release to "DISENGAGE"

IMPORTANT :

- When using the differential lock, always slow the engine down.
- To prevent damage to power train, do not engage differential lock when one wheel is spinning and the other is completely stopped.
- If the differential lock cannot be released, step lightly on the brake pedals alternately.

■ Operating the Tractor on a Road



CAUTION

To avoid personal injury:

- To help assure straight line stops when driving at transport speeds, lock the brake pedals together. Uneven braking at road speeds could cause the tractor to roll-over.
- When traveling on road with 3-point hitch mounted implement attached, be sure to have sufficient front weight on the tractor to maintain steering ability.

Observe all local traffic and safety regulations.

Use the registration plate.

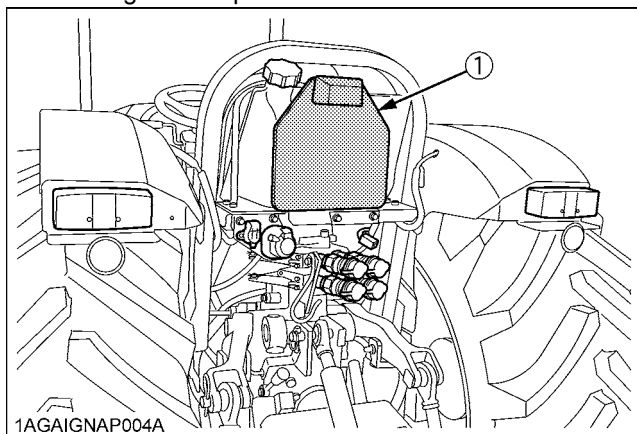

(1) Registration plate

■ Operating on Slopes and Rough Terrain



CAUTION

To avoid personal injury:

- Always back up when going up a steep slope. Driving forward could cause the tractor to tip over backward. Stay off hills and slopes too steep for safe operation.
- Avoid changing gears when climbing or descending a slope.
- If operating on a slope, never disengage the clutch or shift levers to neutral. Doing so could cause loss of control.
- Do not drive the tractor close to the edges of ditches or banks which may collapse under the weight of the tractor. Especially when the ground is loose or wet.

1. Be sure wheel tread is adjusted to provide maximum stability.
(See "WHEEL ADJUSTMENT" in "TIRES, WHEELS AND BALLAST" section.)
2. Slow down for slopes, rough ground, and sharp turns, especially when transporting heavy, rear mounted equipment.
3. Before descending a slope, shift to a gear low enough to control speed without using brakes.

■ Directions for Use of Power Steering

1. Power steering is activated only while the engine is running. Slow engine speeds make the steering a little heavier. While the engine is stopped, the tractor functions in the same manner as tractors without power steering.
2. When the steering wheel is turned all the way to the stop, the relief valve is activated. Do not hold the steering wheel in this position for a long period of time.
3. Avoid turning the steering wheel while the tractor is stopped, or tires may wear out sooner.
4. The power steering mechanism makes the steering easier. Be careful when driving on a road at high speeds.

■ Trailer Electrical Outlet

A trailer electrical outlet is supplied for use with trailer or implement.

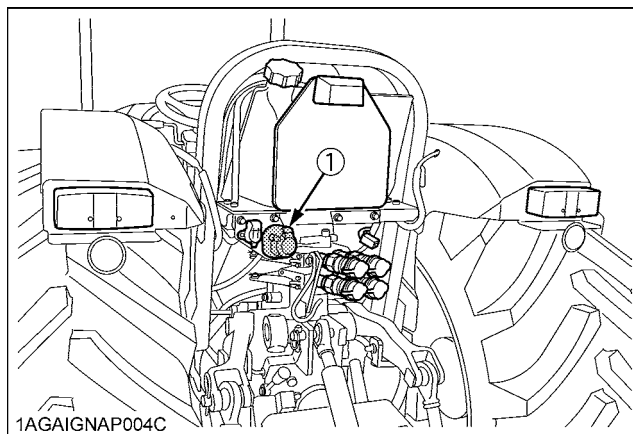

(1) Trailer electrical outlet

◆ **Function of each terminals in trailer electrical outlet**

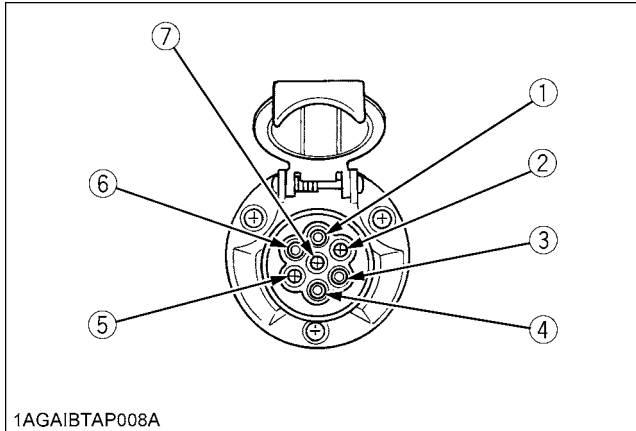

Terminal	Function
(1)	Turn signal light (LH)
(2)	---
(3)	Ground
(4)	Turn signal light (RH)
(5)	Tail light Sidemarker light Parking light
(6)	Brake stop light
(7)	Registration plate light

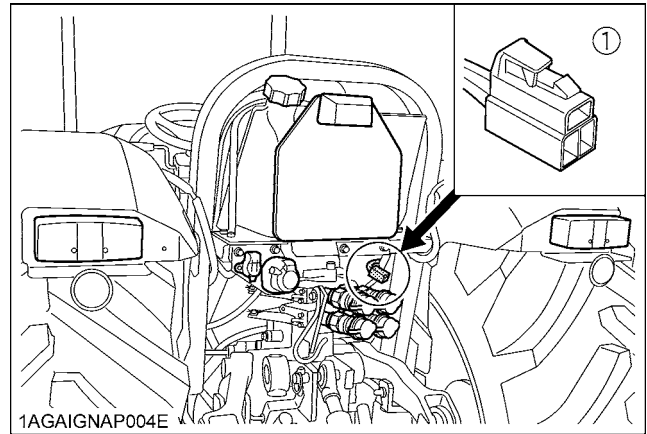

(1) Accessory electrical outlet (15A)

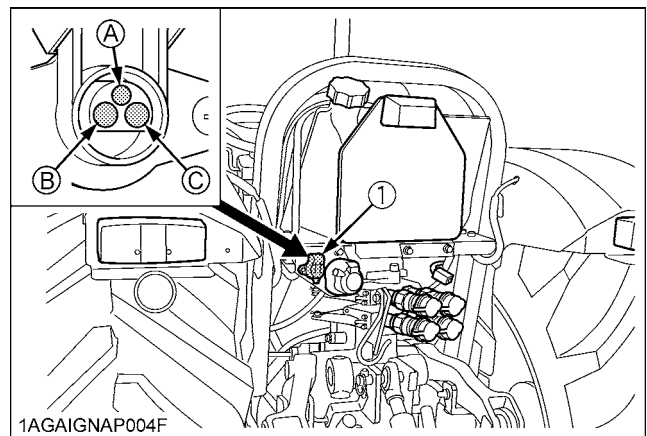

(1) Accessory electrical outlet
 (A) Terminal: Through the ON position of the key switch (15 A)
 (B) Terminal: Through the battery direct (25A)
 (C) Terminal: Ground

■ **Electrical Outlet**

A electrical outlet is supplied for use with implement.

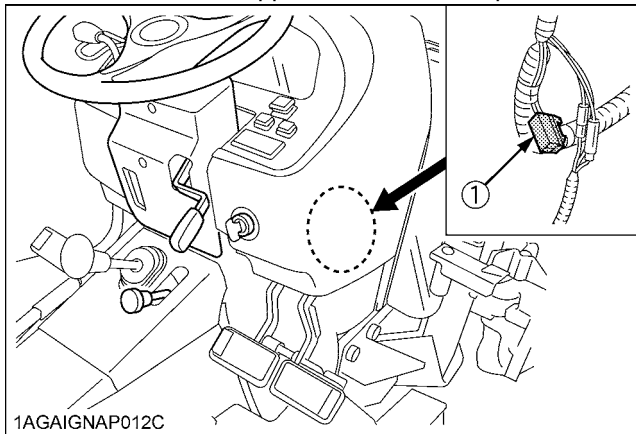

(1) Accessory electrical outlet (15A)

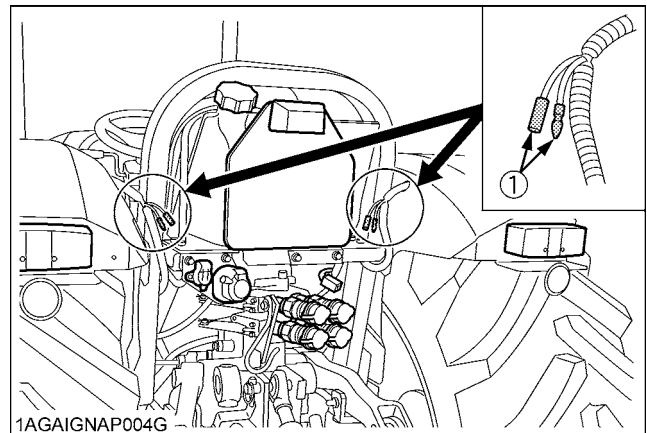

(1) Accessory electrical outlet for rear work light (35W)

PTO

PTO OPERATION



CAUTION

To avoid personal injury:

- Disengage PTO, stop engine, and allow all rotating components to come to a complete stop before connecting, disconnecting, adjusting, or cleaning any PTO driven equipment.

■ PTO Clutch Control Switch

The PTO clutch control switch engages or disengages the PTO clutch which gives the PTO independent control. Turn the switch to "ON" to engage the PTO clutch. Turn the switch to "OFF" to disengage the PTO clutch.

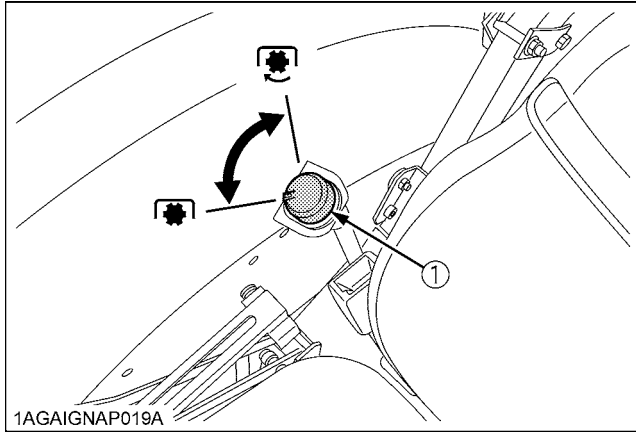

1AGAIGNAP019A

(1) PTO clutch control switch "ON" "OFF"

◆ PTO Clutch Control Switch

To turn ON

While pushing the switch, turn clockwise to the "" position and release your hand. (In the ON position, switch slightly rises itself.)

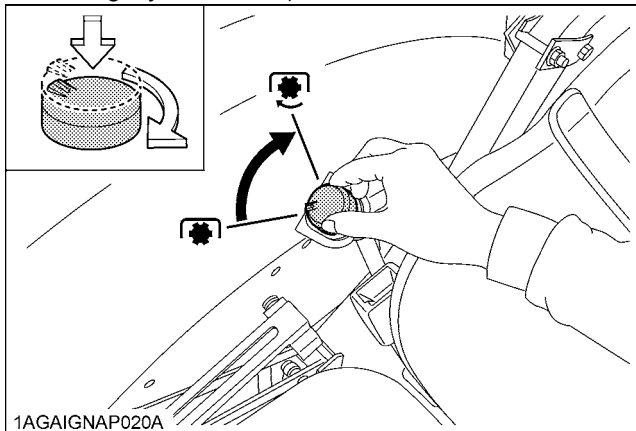

1AGAIGNAP020A

To Turn OFF

Tap on top of the switch, and the switch will return to the OFF position.

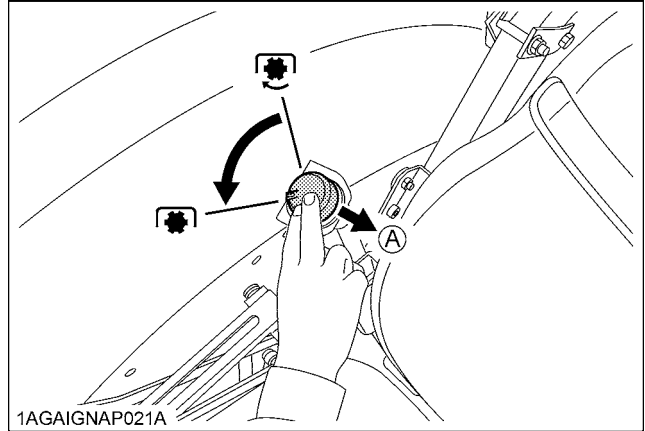

1AGAIGNAP021A

(A) "PUSH"

IMPORTANT :

- To avoid shock loads to the PTO, reduce engine speed when engaging the PTO, then open the throttle to the recommended speed.

NOTE :

- Tractor engine will not start if PTO clutch control switch is in the engaged "ON" position.
- If the PTO system is engaged and you stand up from the seat, the warning buzzer will whistle for about 10 seconds after standing up. This is because the tractor is equipped with "Operator Presence Control System".

◆ PTO Clutch Indicator

The PTO clutch indicator turns on while PTO clutch control switch is in "ON" (Engage) position.

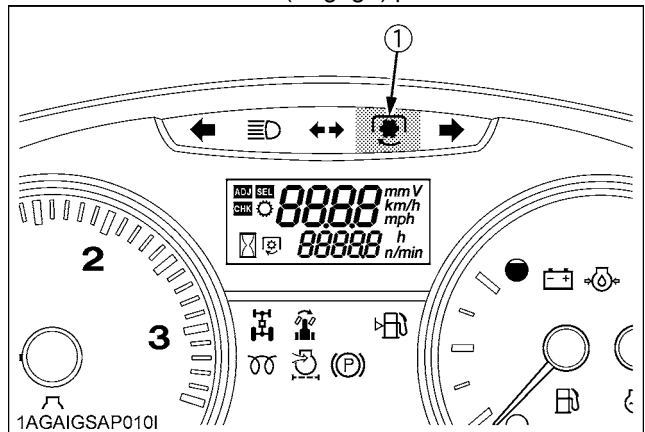

1AGAIGSAP010I

(1) PTO clutch indicator

■ PTO Gear Shift Lever



WARNING

To avoid personal injury:

- Be sure to observe the PTO shaft speed prescribed for the individual implements. It is extremely dangerous to run an implement at high speed that is meant to be operated at low speed. Use only when this higher rpm is specifically recommended by the implement manufacturer.

The PTO gear shift lever can be set to either 540 rpm or 540E rpm positions.

Move this lever to either position with the PTO clutch control switch set to "OFF".

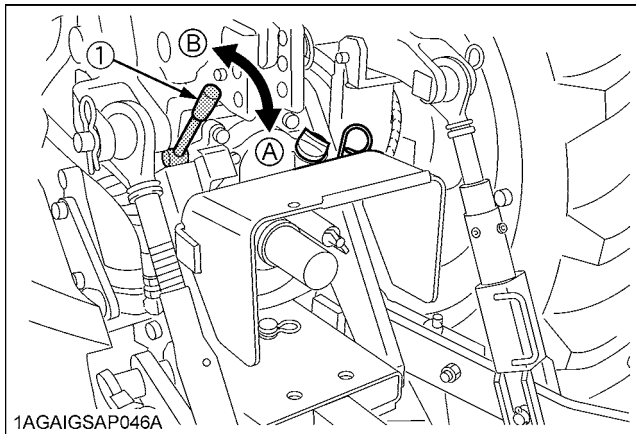

1AGAIGSAP046A

(1) PTO gear shift lever

(A) 540 rpm

(B) 540E rpm

NOTE :

- When light load, select the "540E" position for economical operation.

■ LCD Monitor Message

1. The PTO rpm can be checked in the LCD monitor. (See "PTO RPM / TRAVEL SPEED MONITOR" in "OPERATING THE TRACTOR" section.)
2. When the PTO system gets engaged (ON), the indicator lights up.

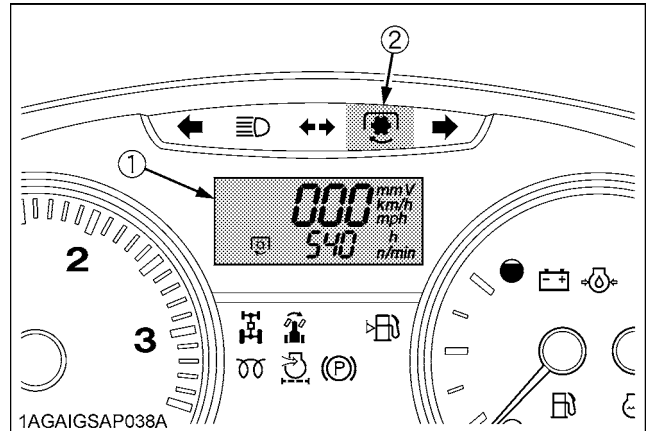

1AGAIGSAP038A

(1) LCD monitor

(2) PTO clutch indicator

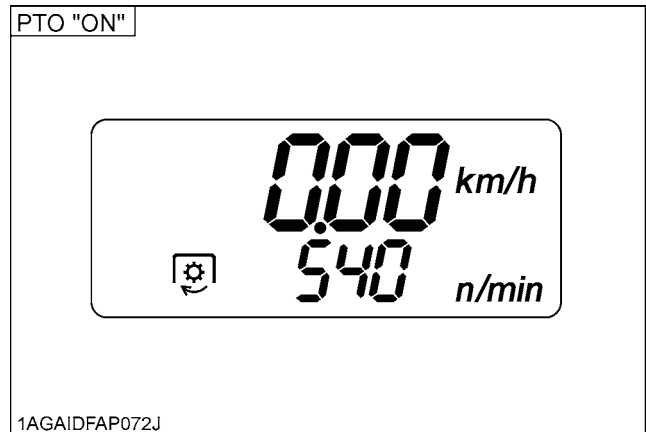

1AGAIDFAP072J

■PTO Shaft Cover and Shaft Cap

Keep the PTO shaft cover in place at all times. Replace the PTO shaft cap when the PTO is not in use. Before connecting or disconnecting a drive shaft to PTO shaft, be sure engine is "OFF".

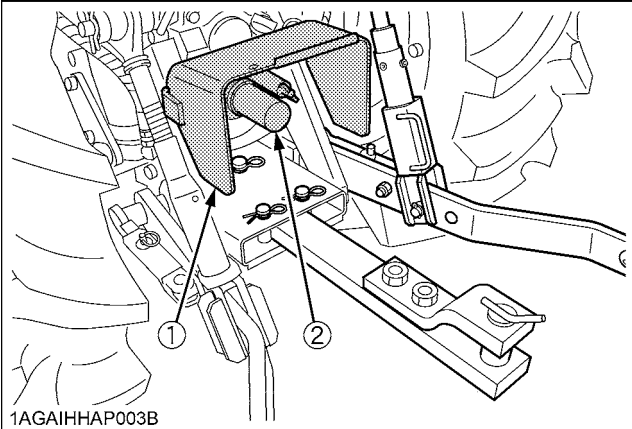

- (1) PTO shaft cover
- (2) PTO shaft cap

THREE-POINT HITCH & DRAWBAR

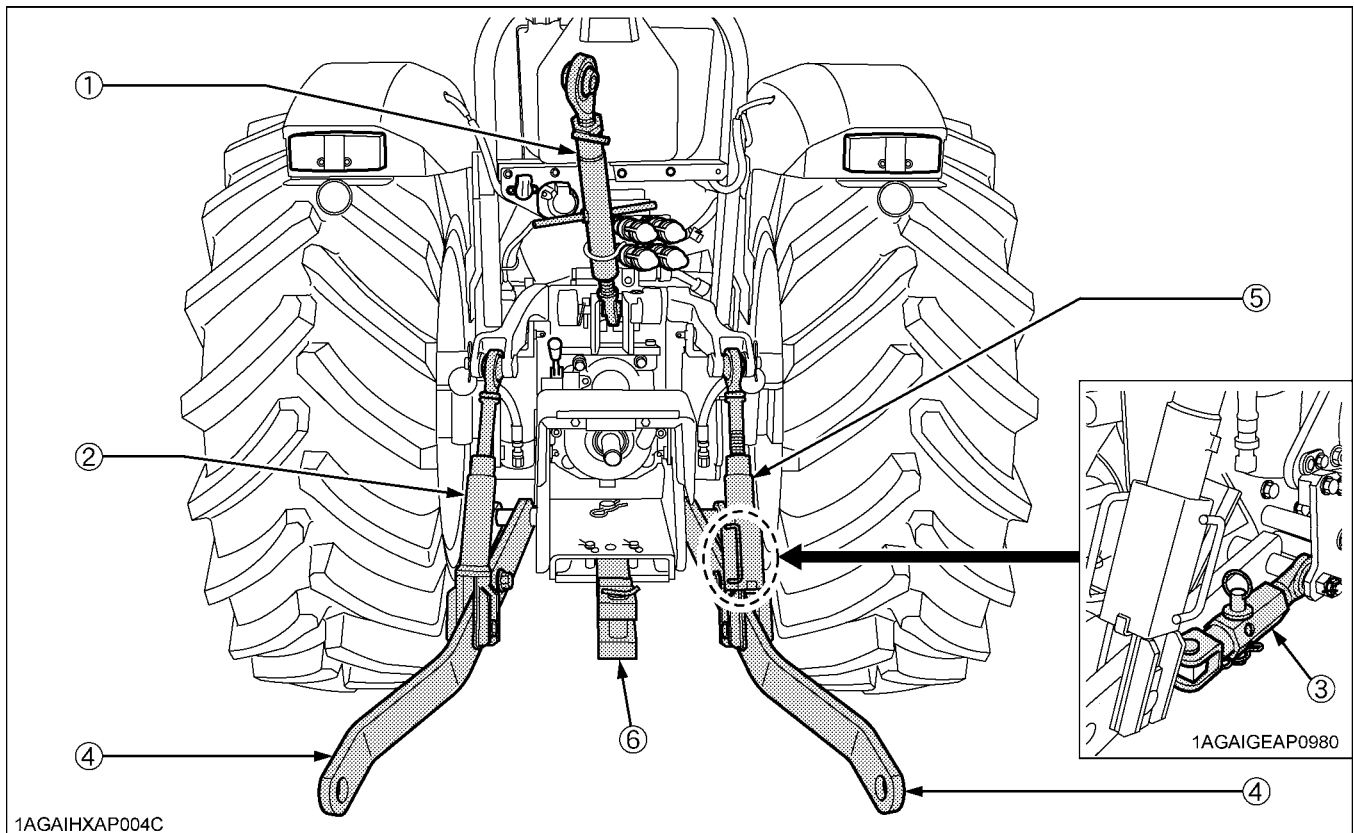

- (1) Top link
- (2) Lifting rod (Left)
- (3) Stabilizer
- (4) Lower link
- (5) Lifting rod (Right)
- (6) Drawbar

3-POINT HITCH

1. Make preparations for attaching implement.

■ Category 1 & 2

The standard tractor has both category 1 & 2. Category 1 type is standard and assemble all parts shown as below.

To change from category 1 to category 2.

1. Remove adjusting collar from the lower link.
2. Add side collar onto both the lower links.
3. Remove adjusting collar from the rear top link pin.
4. Use the correct rear top link pin for category 2.

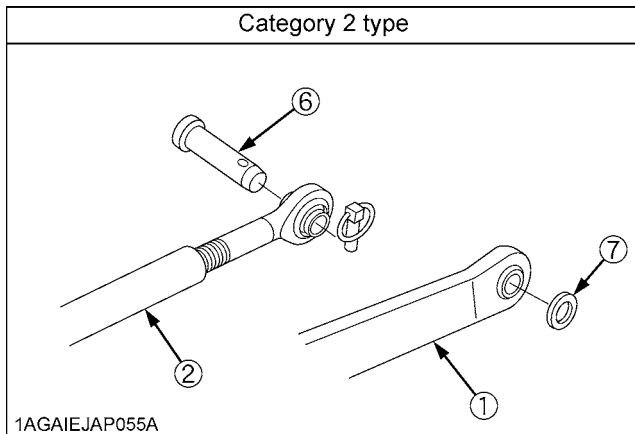
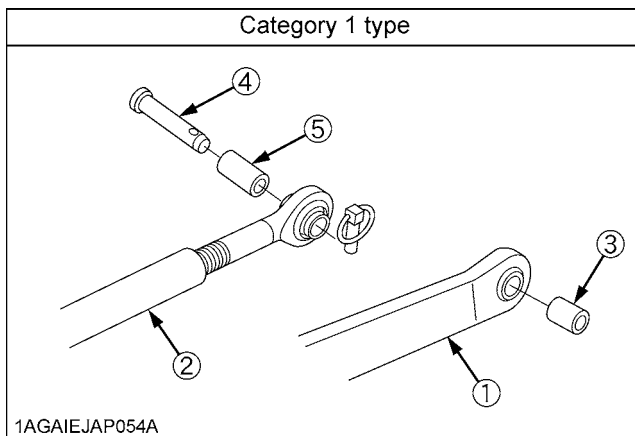

- | | |
|----------------------------|---------------------------|
| (1) Lower link | (5) Collar, top link (1) |
| (2) Top link | (6) Top link rear pin (2) |
| (3) Collar, lower link (1) | (7) Collar, side (2) |
| (4) Top link rear pin (1) | |

■ Selecting the holes of Lower Links

There are two holes in the lower links. For most operations the lifting rods should be attached to the (B) hole.

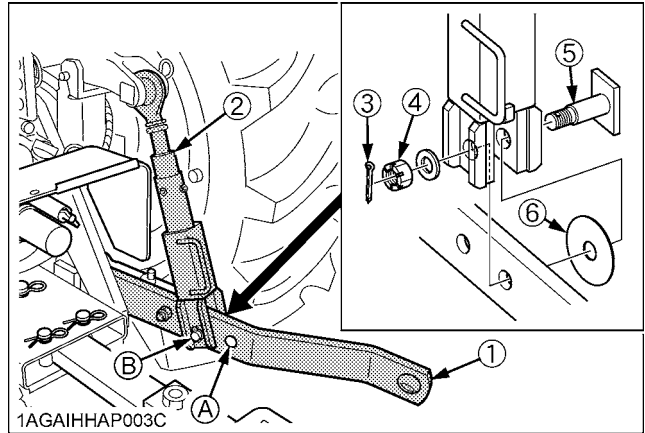

- | | | |
|-----------------|-------------------|-----------------|
| (1) Lower link | (4) Nut | holes: (A), (B) |
| (2) Lifting rod | (5) Lift rod pin | |
| (3) Split pin | (6) Thrust collar | |

NOTE :

- The lifting rods may be attached to (A) for greater lifting force.
- Install the thrust collar in the outside of the lower link.
- Tighten the nut by hand and fix the nut with the cotter pin.

■ Selecting the Top Link Mounting Holes

Select the proper set of holes by referring to the "Hydraulic Control Unit Use Reference Chart" in Hydraulic Unit section.

If the hydraulic unit is set for draft control, draft response is more sensitive when an implement is connected to the lower set of top link mounting holes. If draft control is not required, it is recommended to use the top set (1).

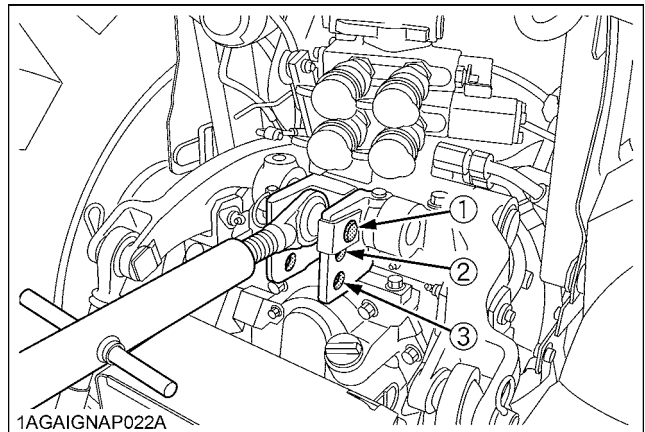

■ **Drawbar**

Remove the drawbar if a close mounted implement is attached.

2. Attaching and detaching implements



CAUTION

To avoid personal injury:

- Be sure to stop the engine.
- Do not stand between tractor and implement unless parking brake is applied.
- Before attaching or detaching implement, locate the tractor and implement on a firm level surface.
- Whenever an implement or other attachment is connected to the tractor 3-point hitch, check full range of operation for interference, binding or PTO separation.
- Do not exceed maximum allowable length of either lifting rod, or the lifting rod will come apart and the 3-point equipment may fall.

■ **Lifting Rod (Left)**

By turning the rod itself, the lifting rod varies its length. When extending the rod, do not exceed the groove on the rod thread.

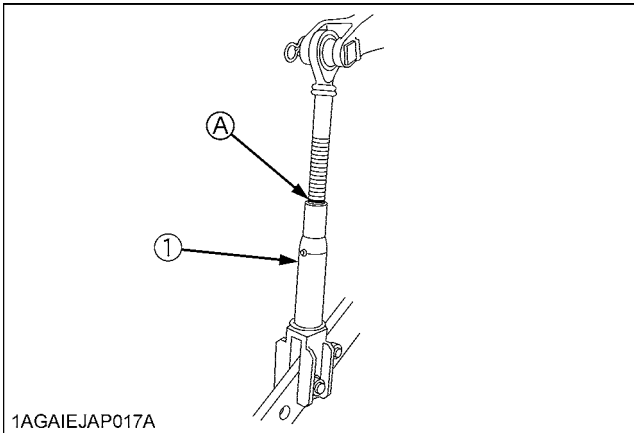

(1) Lifting rod

(A) "GROOVE"

■ **Lifting Rod (Right)**



CAUTION

To avoid personal injury:

- Do not extend lifting rod beyond the groove on the thread rod.

1. To adjust the length of the lifting rod, lift the adjusting handle and turn to desired length.
2. After adjusting, the lifting rod adjusting handle must be returned and stored in the fore and aft position.
3. When extending the rod using adjusting handle, do not exceed the groove on the rod thread.

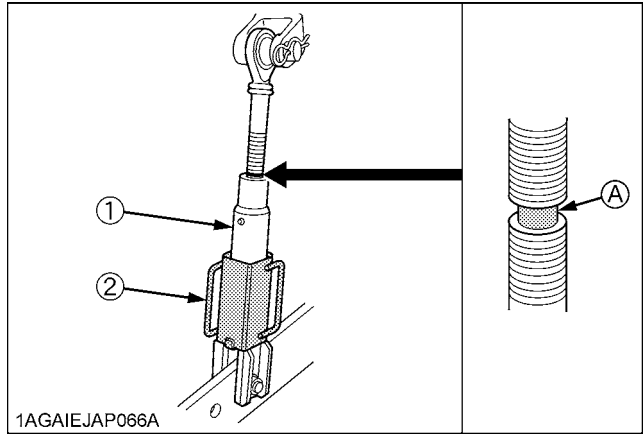

1AGAIEJAP066A

(1) Lifting rod

(2) Adjusting handle

(A) "GROOVE"

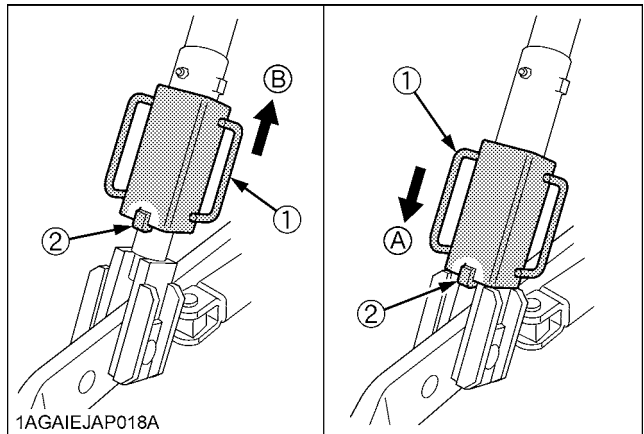

1AGAIEJAP018A

(1) Adjusting handle

(2) Lock pin

(A) "LOCK POSITION"

(B) "UNLOCK POSITION"

Top Link

1. Adjust the angle of the implement to the desired position by shortening or lengthening the top link.
2. The proper length of the top link varies according to the type of implement being used.

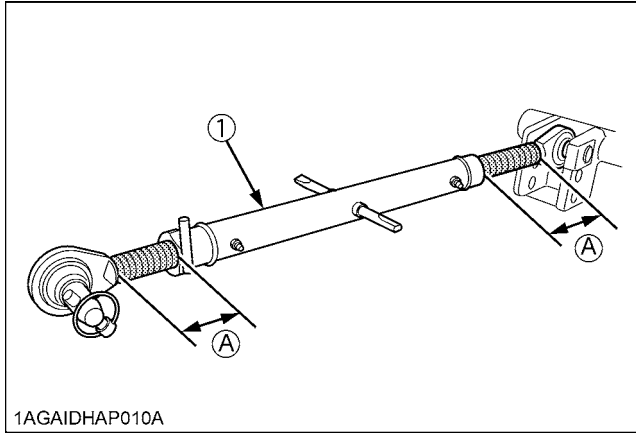

1AGAIDHAP010A

(1) Top link

(A) "Length of the screw"

NOTE :

- The length of the screw at both ends of the top link must be the same always.

Stabilizer

Adjust the stabilizers to control horizontal sway of the implement.

Turn the outer tube until one of its holes aligns with the inner tube hole. Insert the set-pin to lock the outer and inner tubes.

When readjusting, make sure both the stabilizers are equal in overall length.

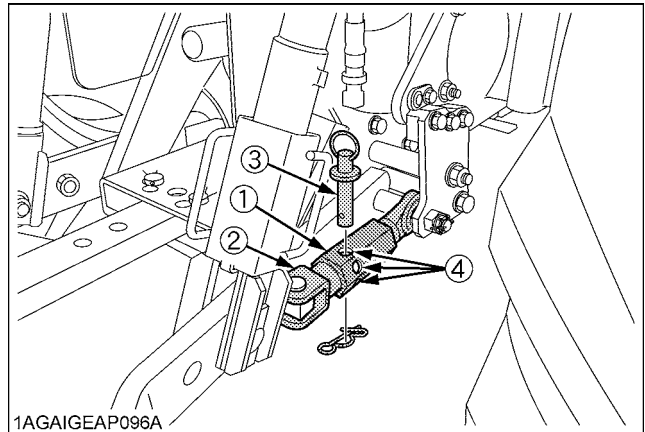

1AGAIGEAP096A

- (1) Outer tube
- (2) Inner tube
- (3) Set-pin
- (4) Hole

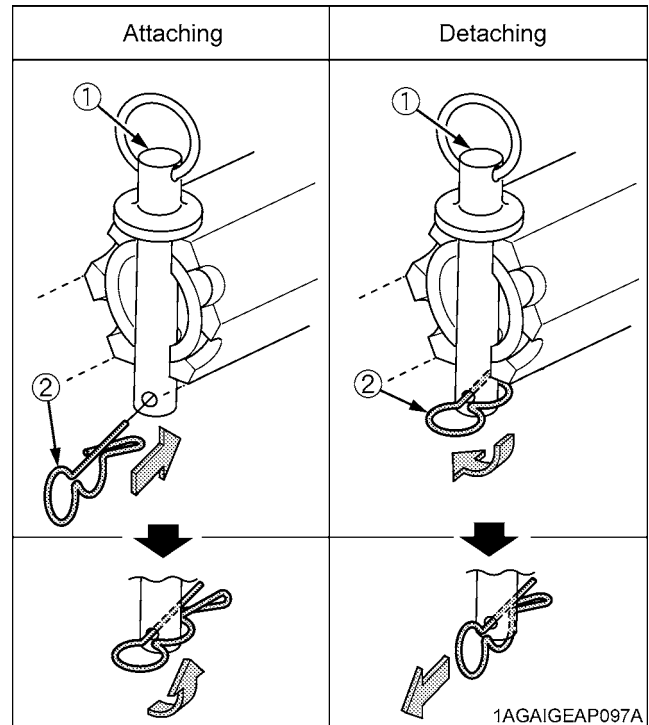

1AGAIGEAP097A

- (1) Set-pin
- (2) Hairpin cotter

DRAWBAR



WARNING

To avoid personal injury:

- Never pull from the top link, the rear axle or any point above the drawbar. Doing so could cause the tractor to tip over rearward causing personal injury or death.

■ Adjusting Drawbar Length

When towing an implement, it is recommended that the (A) hole in drawbar be utilized.

The drawbar load is specified in the "IMPLEMENT LIMITATIONS" section.

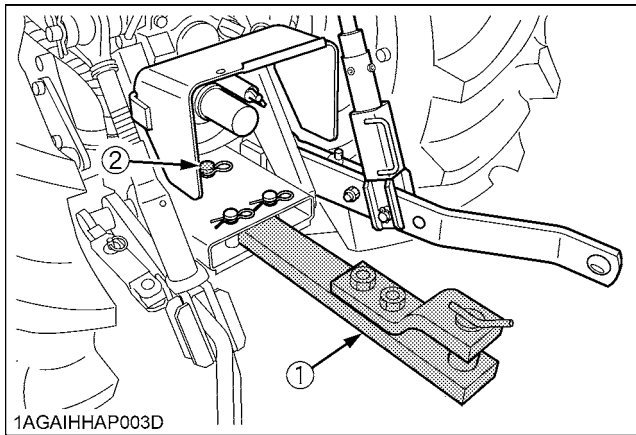

■ Swing Drawbar

The drawbar can be used in three different ways as illustrated below. Assemble it correctly with locating pins.

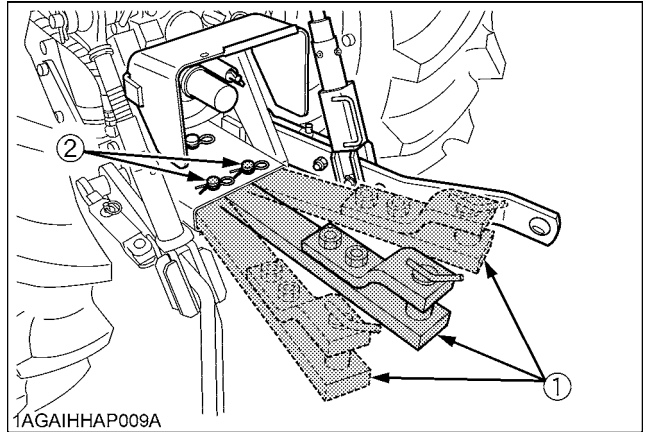

- (1) Drawbar
(2) Locating pin

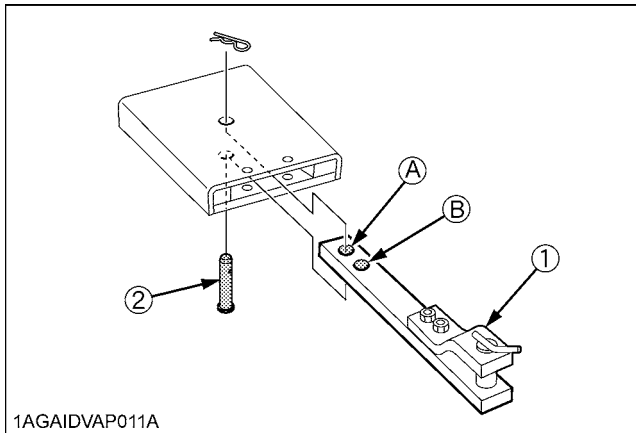

- (1) Drawbar
(2) Pivot pin

Holes: (A), (B)

HYDRAULIC UNIT

The standard tractor has following hydraulic control systems as shown below. Therefore, use the most appropriate system for the implement you are using.

◆ 3-Point Hitch Control System

1. Position Control
2. Draft Control
3. Mixed Control
4. Float Control

◆ Remote Hydraulic Control System

IMPORTANT :

- Do not operate until the engine is warmed up. If operation is attempted when the engine is still cold, the hydraulic system may be damaged.
- If noises are heard when implement is lifting after the hydraulic control lever has been activated, the hydraulic mechanism is not adjusted properly. Unless corrected, the unit will be damaged. Contact your KUBOTA Dealer for adjustment.

3-POINT HITCH CONTROL SYSTEM

■ Position Control

This will control the working depth of 3-point hitch mounted implement regardless of the amount of pull required.

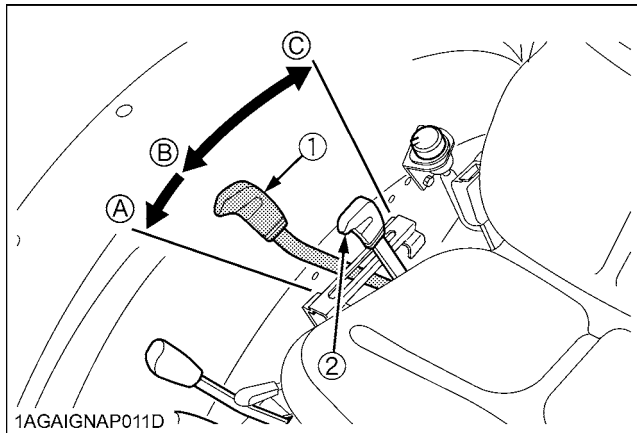

- | | |
|----------------------------|-------------|
| (1) Position control lever | (A) "FLOAT" |
| (2) Draft control lever | (B) "DOWN" |
| | (C) "UP" |

■ Draft Control

This will control the pull of the 3-point implement. As the load on the 3-point hitch changes due to various soil conditions, the draft control system automatically responds to these changes by either raising or lowering the implement slightly to maintain a constant pull.

Place the position control lever in the lowest position and set the implement pull with the draft control lever.

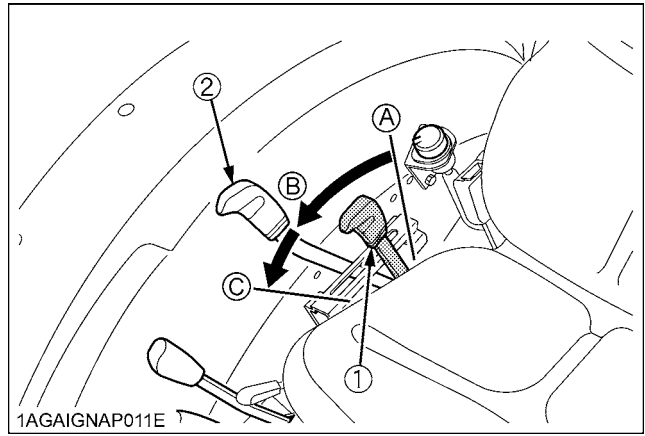

- | | |
|----------------------------|-------------------|
| (1) Draft control lever | (A) "SENSITIVE" |
| (2) Position control lever | (B) "INSENSITIVE" |
| | (C) "FLOAT" |

■ Mixed Control

In draft control, when draft decreases, the implement automatically lowers to increase draft. However, the implement sometimes lowers too much. To limit the degree, the implement can be lowered, set the position control lever at the lowest working depth desired for the implement. Lower the draft control lever to the point where the implement is at the desired depth.

This stops the implement from going too deep and causing loss of traction and ground speed.

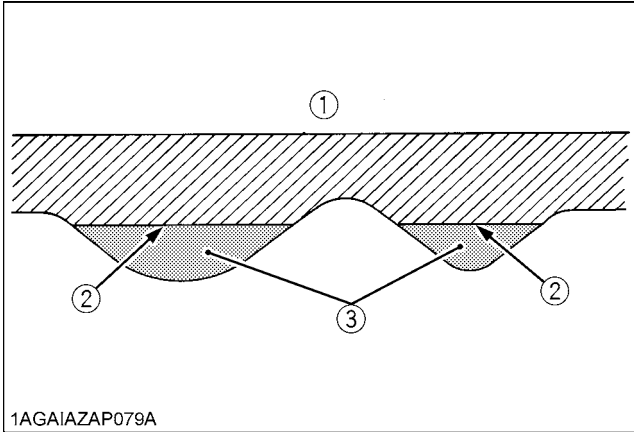

1AGAIAZAP079A

- (1) Ground surface
- (2) Implement penetration limit
- (3) Light soil

Float Control

Place both the draft control lever and the position control lever in the float position to make the lower links move freely along with the ground conditions.

3-point Hitch Lowering Speed



CAUTION

To avoid personal injury:

- Fast lowering speed may cause damage or injury. Lowering speed of implement should be adjusted to two or more seconds.

The lowering speed of the 3-point hitch can be controlled by adjusting the 3-point hitch lowering speed lever.

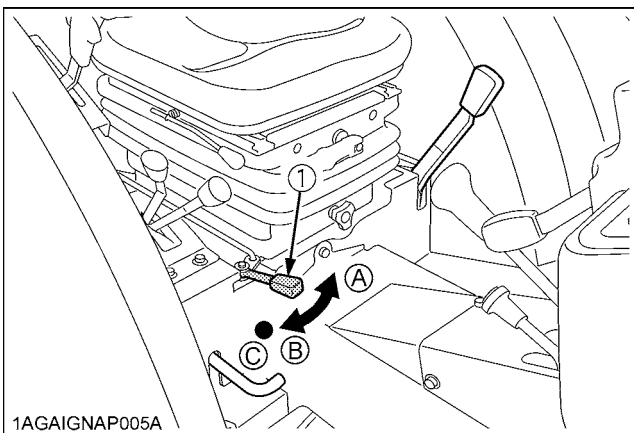

1AGAIGNAP005A

- (1) 3-Point hitch lowering speed lever
- (A) "FAST"
- (B) "SLOW"
- (C) "LOCK"

REMOTE HYDRAULIC CONTROL SYSTEM

The hydraulic auxiliary control valves can be installed up to triple segments.

It is not possible to use triple segments with flow control valve.

Remote Control Valve

The standard tractor is equipped with double acting valve.

- Double acting valve with detents and self cancelling: This valve may be placed in the detent mode. The lever will stay in this position until the pressure reaches a predetermined level or a cylinder reaches the end of its stroke. Then it will automatically return to neutral.

Remote Control Valve Lever

The remote control valve lever directs pressurized oil flow to the implement hydraulic system.

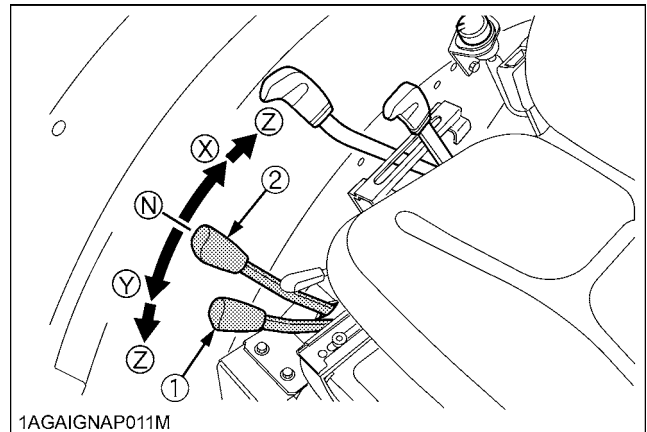

1AGAIGNAP011M

- (1) Remote control valve lever 1
- (2) Remote control valve lever 2
- (X) "REARWARD"
- (Y) "FORWARD"
- (Z) "DETENT POSITION"

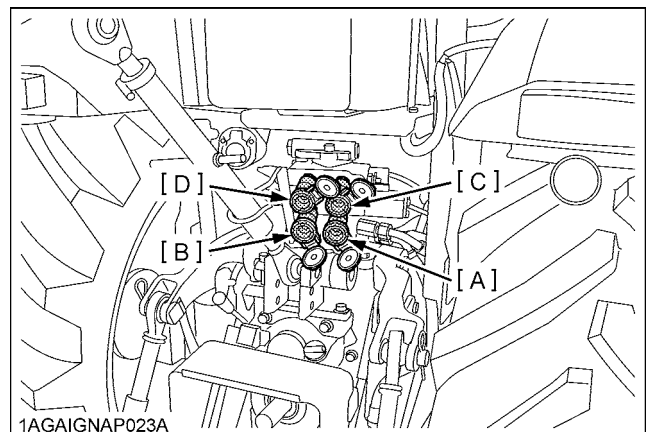

1AGAIGNAP023A

Pressure →
Returning ←

Lever (1)		Lever position			
		Z	Y	X	Z
Port	(A)	out →		in ←	
	(B)	in ←		out →	

Lever (2)		Lever position			
		Z	Y	X	Z
Port	(C)	out →		in ←	
	(D)	in ←		out →	

IMPORTANT :

- Do not hold the lever in the "REARWARD" or "FORWARD" position once the remote cylinder has reached the end of the stroke, as this will cause oil to flow through the relief valve. Forcing oil through the relief valve for extended periods will overheat the oil.
- When using the tractor hydraulic system to power front loader, do not operate boom and bucket cylinders simultaneously.

NOTE :

- Connect the pressure of load side of implement cylinders to ports [B] or [D] which have built in load check valve to prevent leak down.

Remote Control Valve Coupler Connecting and Disconnecting



CAUTION

To avoid personal injury:

- Stop the engine and relieve pressure before connecting or disconnecting lines.
- Do not use your hand to check for leaks.

◆ **Connecting**

1. Clean both couplers.
2. Remove dust plugs.
3. Insert the implement coupler to the tractor hydraulic coupler.
4. Pull the implement coupler slightly to make sure couplers are firmly connected.

◆ **Disconnecting**

1. Lower the implement first to the ground to release hydraulic pressure in the hoses.
2. Clean the couplers.
3. Relieve pressure by moving hydraulic control levers with engine shut off. Pull the hose straight from the hydraulic coupler to release it.
4. Clean oil and dust from the coupler, then replace the dust plugs.

NOTE :

- Your local KUBOTA Dealer can supply parts to adapt couplers to hydraulic hoses.

Hydraulic Control Unit Use Reference Chart

In order to handle the hydraulics properly, the operator must be familiar with the following.

Though this information may not be applicable to all types of implements and soil conditions, it is useful for general conditions.

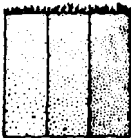
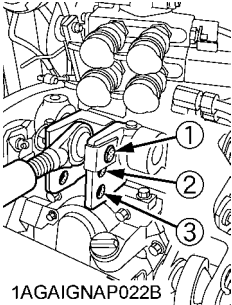
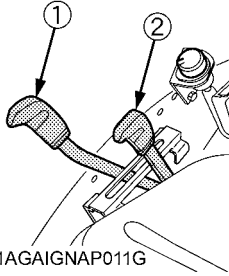
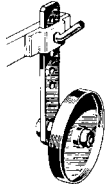
Implement	 1AGAI AZAP122A Soil condition	 1AGAI GNAP022B Top link mounting holes	 1AGAI GNAP011G (1) Position control lever (2) Draft control lever	 1AGAI AZAP070A Gauge wheel
Moldboard plow	Light soil Medium soil Heavy soil	3 2 or 3 2	Draft and Mixed control (Place the draft control lever to the suitable position and set the implement pull with the position control lever.)	YES/NO
Disc plow	---	2 or 3		
Harrower (spike, springtooth, disc type)	---	2		
Sub-soiler.....				
Weeder, ridger.....			Position control (Hold the draft control lever at the front most position during operation.)	YES
Earthmover, digger, scraper, manure fork, rear carrier.....	---	1		YES/NO
Mower (mid- and rear-mount type) Hayrake, tedder.....				NO

TIRES, WHEELS AND BALLAST

TIRES



WARNING

To avoid personal injury:

- Do not attempt to mount a tire on a rim. This should be done by a qualified person with the proper equipment.
- Always maintain the correct tire pressure. Do not inflate tires above the recommended pressure shown in the operator's manual.

IMPORTANT :

- Do not use tires other than those approved by KUBOTA.

NOTE :

- When optional different-diameter tires are fitted on the machine, the travel speed display mode must be changed. Otherwise the travel speed will not get correctly displayed. Such mode switching is also needed when the original tires are back on the machine.
(See "PTO RPM / TRAVEL SPEED MONITOR" in "OPERATING THE TRACTOR" section.)

■ Inflation Pressure

Though the tire pressure is factory-set to the prescribed level, it naturally drops slowly in the course of time. Thus, check it everyday and inflate as necessary.

NOTE :

- Maintain the maximum pressure in front tires, if using a front loader or when equipped with a full load of front weights.

	Tire sizes	Inflation Pressure
Front	280 / 70R18	196 kPa (2.0 kgf/cm ²)
Rear	420 / 70R24	120 kPa (1.2 kgf/cm ²)
	380 / 70R28	120 kPa (1.2 kgf/cm ²)

■ Dual Tires

Dual tires are not approved.

■ Treads

IMPORTANT :

- Front and rear treads can not be adjusted.
- Always attach the wheels as shown in the factory-shipment state, otherwise tractor parts may be damaged.
- When re-fitting or adjusting a wheel, tighten the bolts to the following torques then recheck after driving the tractor 200m (200 yards) and 10 times of shuttle movement by 5 m (5 yards), and thereafter according to service interval.
(See "MAINTENANCE" section.)

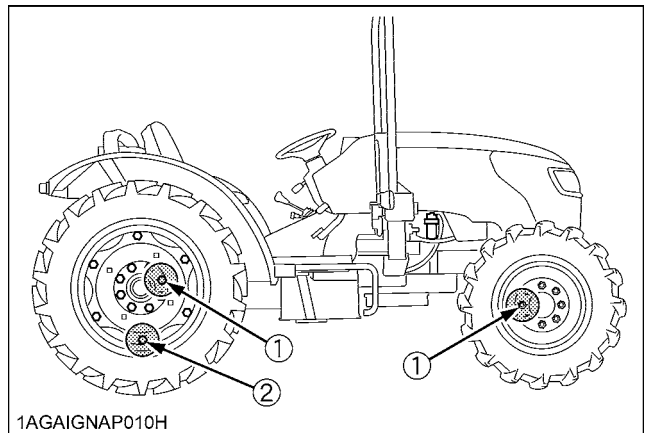

N-m (kgf-m)

(1)	(2)
260 to 304 (26.5 to 31.0)	244 (24.9)

Front	Rear	
<p>1AGAIGSAP067A</p>	<p>1AGAIFSAP064A</p>	
280 / 70R18	420 / 70R24	380 / 70R28
1150 mm	1066 mm	1046 mm

BALLAST



CAUTION

To avoid personal injury:

- Additional ballast will be needed for transporting heavy implements. When the implement is raised, drive slowly over rough ground, regardless of how much ballast is used.
- Do not fill the front wheels with liquid to maintain steering control.

■ Front Ballast

Add weights if needed for stability and improve traction. Heavy pulling and heavy rear mounted implements tend to lift front wheels.

Add enough ballast to maintain steering control and prevent tip over. Remove weight when no longer needed.

◆ Front End Weights (option)

The front end weights can be attached to the bumper. See your implement operator's manual for required number of weights or consult your local KUBOTA Dealer to use.

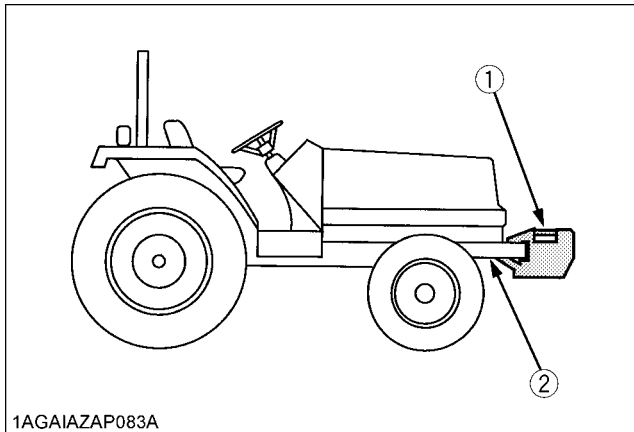

(1) Front end weights
(2) Bumper

IMPORTANT :

- Do not overload tires.
- Add no more weight than indicated in chart.
- Do not attach the front bumper when the front loader is attached.

Maximum weight	45 kg x 10 pieces
----------------	-------------------

■ Rear Ballast

Add weight to rear wheels if needed to improve traction or for stability. The amount of rear ballast should be matched to job and the ballast should be removed when it is not needed.

The weight should be added to the tractor in the form of liquid ballast, rear wheel weights or a combination of both.

◆ Rear Wheel Weights (option)

The rear wheel weights can be attached to the rear wheel. See your implement operator's manual for required number of weights or consult your local KUBOTA Dealer to use.

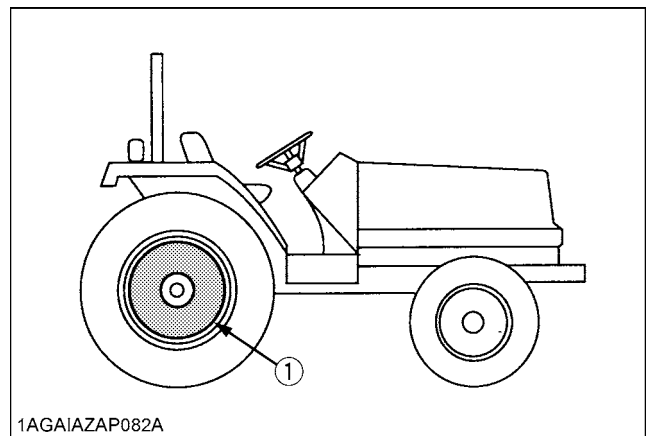

(1) Rear wheel weights

IMPORTANT :

- Do not overload tires.
- Add no more weight than indicated in chart.

Maximum weight per wheel	40 kg x 2 pieces
--------------------------	------------------

MAINTENANCE

SERVICE INTERVALS

No.	Items		Indication on hour meter													Interval	Ref. page		
			50	100	150	200	250	300	350	400	450	500	550	600	650				700
1	Engine start system	Check	○	○	○	○	○	○	○	○	○	○	○	○	○	○	every 50 Hr	58	
2	Wheel bolt torque	Check	○	○	○	○	○	○	○	○	○	○	○	○	○	○	every 50 Hr	59	
3	Battery condition	Check		○		○		○		○		○		○		every 100 Hr	63	*5	
4	Greasing	---		○		○		○		○		○		○		every 100 Hr	59		
5	Alternator belt	Adjust		○		○		○		○		○		○		every 100 Hr	61		
6	Brake Pedal	Adjust		○		○		○		○		○		○		every 100 Hr	61		
7	Air cleaner element Primary element	Clean		○		○		○		○		○		○		every 100 Hr	60	*1	
		Replace															every 1 year	71	*2
	Secondary element	Replace														every 1 year	71		
8	Fuel line	Check		○		○		○		○		○		○		every 100 Hr	61		
		Replace															every 2 years	72	*4
9	Parking brake (cable)	Adjust		○		○		○		○		○		○		every 100 Hr	62		
		Replace															every 2 years	72	*4
10	Toe-in	Adjust				○								○		every 200 Hr	65		
11	Fuel tank water	Drain				○								○		every 200 Hr	66		
12	Power steering oil line	Check				○								○		every 200 Hr	65		
		Replace															every 2 years	72	*4
13	Radiator hose and clamp	Check				○								○		every 200 Hr	64		
		Replace															every 2 years	72	
14	Intake air line	Check				○								○		every 200 Hr	65		
		Replace															every 2 years	72	*3
15	Engine oil	Change	◎					○						○		every 300 Hr	66		
16	Hydraulic oil filter	Replace	◎					○						○		every 300 Hr	67		

No.	Items		Indication on hour meter													Interval	Ref. page			
			50	100	150	200	250	300	350	400	450	500	550	600	650				700	
17	Water separator	Clean																every 400 Hr	68	
18	Fuel filter	Replace																every 400 Hr	68	
19	Engine oil filter	Replace	⊙													⊙		every 600 Hr	69	
20	Transmission fluid	Change	⊙													⊙		every 600 Hr	69	
21	Front differential case oil	Change	⊙													⊙		every 600 Hr	70	
22	Front axle gear case oil	Change	⊙													⊙		every 600 Hr	70	
23	Front axle pivot	Adjust														⊙		every 600 Hr	70	
24	Engine valve clearance	Adjust																every 800 Hr	70	*4
25	Fuel injection nozzle injection pressure	Check																every 1500 Hr	70	*4
26	Turbo charger	Check																every 3000 Hr	71	*4
27	Injection pump	Check																every 3000 Hr	71	*4
28	Intake air heater	Check																every 3000 Hr	71	*4
29	Cooling system	Flush																every 2 years	71	
30	Coolant	Change																every 2 years	71	
31	Master cylinder filter	Clean																every 2 years	72	*4
32	Lift cylinder hose	Replace																every 2 years	73	*4
33	Master cylinder kit	Replace																every 2 years	73	*4
34	Equalizer kit	Replace																every 2 years	73	*4
35	Brake seal 1 and 2	Replace																every 2 years	73	*4
36	Fuel system	Bleed																Service as required	73	
37	Brake system	Bleed																Service as required	74	*4
38	Clutch housing water	Drain																Service as required	74	
39	Fuse	Replace																Service as required	74	
40	Light bulb	Replace																Service as required	75	

IMPORTANT :

- The jobs indicated by ☉ must be done after the first 50 hours of operation.
- *1 Air cleaner should be cleaned more often in dusty conditions than in normal conditions.
- *2 Every year or every 6 times of cleaning.
- *3 Replace only if necessary.
- *4 Consult your local KUBOTA Dealer for this service.
- *5 When the battery is used for less than 100 hours per year, check the battery condition by reading the indicator annually.

LUBRICANTS, FUEL AND COOLANT

No.	Locations	Capacities	Lubricants	
1	Fuel	60 L	No.2-D diesel fuel No.1-D diesel fuel if temperature is below -10 °C	
2	Coolant	9 L (Recovery tank: 1.0 L)	Fresh clean soft water with anti-freeze	
3	Engine crankcase (with filter)	10.7 L	● Engine oil: API Service Classification	CF or CI-4 [External EGR type engine]
			Above 25 °C	SAE30, SAE10W-30 or 15W-40
			0 to 25 °C	SAE20, SAE10W-30 or 15W-40
			Below 0 °C	SAE10W, SAE10W-30 or 15W-40
4	Transmission case	52 L	● KUBOTA UDT or SUPER UDT fluid*	
5	Front differential case oil	5.0 L	● KUBOTA UDT or SUPER UDT fluid* or SAE 80 - SAE 90 gear oil	
6	Front axle gear case oil	3.0 L		
7	Greasing	No. of greasing points	Capacity	Type of grease
	Top link	2	Until grease overflows.	Multipurpose Grease NLGI-2 OR NLGI-1(GC-LB)
	Top link bracket	2		
	Lift rod	2		
	Hydraulic lift cylinder pin	4		
	Front axle gear case support	2		
	Front axle support	2		
	Battery terminal	2	A small amount	

NOTE :

* KUBOTA UDT or SUPER UDT fluid... KUBOTA original transmission hydraulic fluid

NOTE :

◆ **Engine Oil:**

- Oil used in the engine should have an American Petroleum Institute (API) service classification and Proper SAE Engine Oil according to the ambient temperatures as shown above:
- With the emission control now in effect, the CF-4 and CG-4 lubricating oils have been developed for use of a low-sulfur fuel on on-road vehicle engines. When an off-road vehicle engine runs on a high-sulfur fuel, it is advisable to employ the "CF or better" lubricating oil with a high Total Base Number (TBN of 10 minimum).
- Refer to the following table for the suitable API classification engine oil according to the engine type (with internal EGR, external EGR or non-EGR) and the fuel (low-sulfur or high-sulfur fuel).

Fuel used	Engine oil classification (API classification)	
	Oil class of engines except external EGR	Oil class of engines with external EGR
High Sulfur Fuel [≥ 0.05% (500 ppm)]	CF (If the "CF-4, CG-4, CH-4 or CI-4" lubricating oil is used with a high-sulfur fuel, change the lubricating oil at shorter intervals. (approximately half))	---
Low Sulfur Fuel [<0.05% (500 ppm)] or Ultra Low Sulfur Fuel [<0.0015% (15 ppm)]	CF, CF-4, CG-4, CH-4 or CI-4	CF or CI-4 (Class CF-4, CG-4 and CH-4 engine oils cannot be used on EGR type engines)

EGR: Exhaust Gas Re-circulation

- The CJ-4 engine oil is intended for DPF (Diesel Particulate Filter) type engines, and cannot be used on this tractor.

◆ **Fuel:**

- Cetane number of 45 minimum. Cetane number greater than 50 is preferred, especially for temperatures below -20 °C or elevations above 1500 m.
- If diesel fuel with sulfur content greater than 0.5% (5000 ppm) sulfur content is used, reduce the service interval for engine oil and filter by 50%.
- NEVER use diesel fuel with sulfur content greater than 0.05% (500 ppm) for EXTERNAL EGR type engine.
- DO NOT use diesel fuel with sulfur content greater than 1.0% (10000 ppm).
- Diesel fuels specified to EN 590 or ASTM D975 are recommended.
- No.2-D is a distillate fuel of lower volatility for engines in industrial and heavy mobile service. (SAE J313 JUN87)

◆ **Transmission Oil:**

The oil used to lubricate the transmission is also used as hydraulic fluid. To insure proper operation of the hydraulic system and to complete lubrication of the transmission, it is important that a multi-grade transmission fluid is used in this system. We recommend the use of **KUBOTA UDT or SUPER UDT fluid** for optimum protection and performance. (Consult your local KUBOTA Dealer for further detail.)

Do not mix different brands together.

- Indicated capacities of water and oil are manufacturer's estimate.

PERIODIC SERVICE



CAUTION

To avoid personal injury:

- Do not work under any hydraulically supported devices. They can settle, suddenly leak down, or be accidentally lowered. If necessary to work under tractor or any machine elements for servicing or adjustment, securely support them with stands or suitable blocking beforehand.

HOW TO OPEN THE HOOD



CAUTION

To avoid personal injury from contact with moving parts;

- Never open the hood while the engine is running.
- Do not touch muffler or exhaust pipes while they are hot; Severe burns could result.
- Hold the hood with other hand while unlocking release lever.

■ Hood

To open the hood, hold the hood and pull the release lever and open the hood.

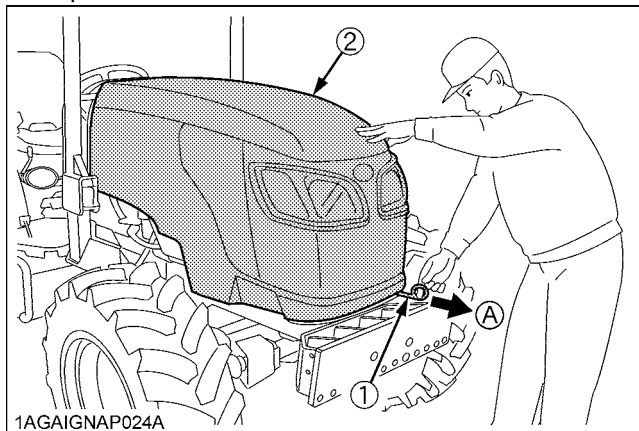

(1) Release lever
(2) Hood

(A) "PULL"

NOTE :

- To close the hood, push the hood into position using both hands.

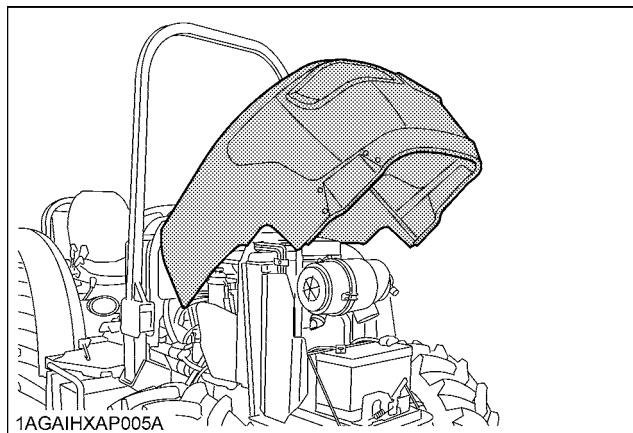

DAILY CHECK

For your own safety and maximum service life of the machine, make a thorough daily inspection before operating the machine to start the engine.



CAUTION

To avoid personal injury:

- Be sure to check and service the tractor on a level surface with the engine shut off and the parking brake "ON" and implement lowered to the ground.

■ Walk Around Inspection

Look around and under the tractor for such items as loose bolts, trash build-up, oil or coolant leaks, broken or worn parts.

■Checking and Refueling

CAUTION

To avoid personal injury:

- Do not smoke while refueling.
- Be sure to stop the engine before refueling.

1. Check the amount of fuel by fuel gauge.
2. When the fuel warning indicator lights up, it is time to add fuel.

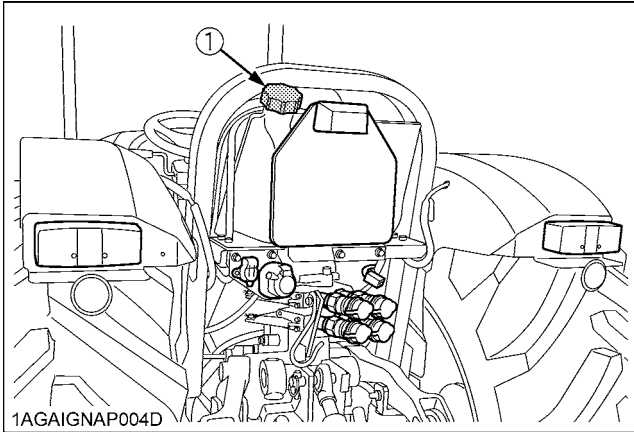

(1) Fuel tank cap

Fuel tank capacity	60 L
--------------------	------

IMPORTANT :

- Do not permit dirt or trash to get into the fuel system.
- Be careful not to let the fuel tank become empty, otherwise air will enter the fuel system, necessitating bleeding before next engine start.
- Be careful not to spill during refueling. If a spill should occur, wipe it off at once, or it may cause a fire.
- To prevent condensation (water) accumulation in the fuel tank, fill the tank before parking overnight.

■Checking Water Separator

1. As water is collected in the water separator, the red float is raised.
2. When the red float has reached the white line, close the fuel cock, loosen the retainer ring, take out the cup, and clean the cup. Be careful not to break the element.
3. Place the cup back into position. Bleed the fuel system.
(See "SERVICE AS REQUIRED" in "PERIODIC SERVICE" section.)

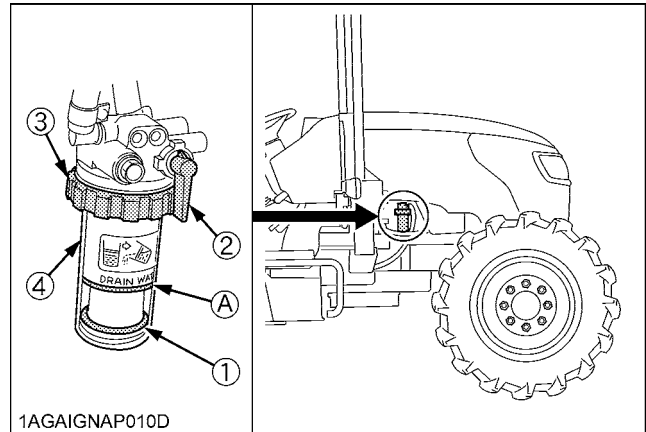

- (1) Red float
- (2) Fuel cock
- (3) Retainer ring
- (4) Cup

(A) "WHITE LINE"

IMPORTANT :

- If water is drawn through to the fuel pump, extensive damage will occur.

■Checking Engine Oil Level

CAUTION

To avoid personal injury:

- Be sure to stop the engine before checking the oil level.

1. Park the machine on a flat surface.
2. Check engine oil before starting the engine or 5 minutes or more after the engine has stopped.
3. To check the oil level, draw out the dipstick, wipe it clean, replace it, and draw it out again. Check to see that the oil level lies between the two notches.
If the level is too low, add new oil to the prescribed level at the oil inlet.
(See "LUBRICANTS" in "MAINTENANCE" section.)

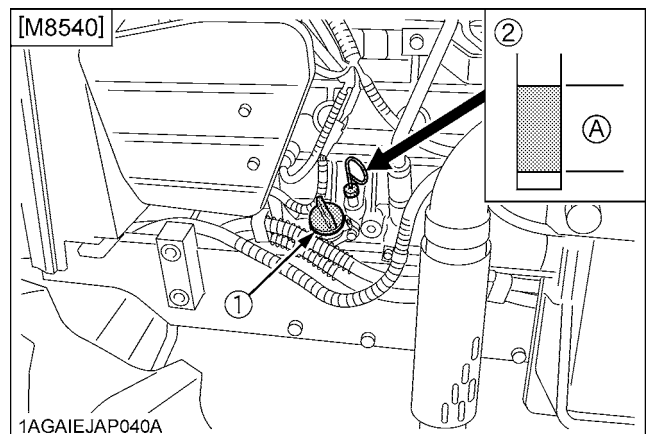

- (1) Oil inlet
- (2) Dipstick
- (A) Oil level is acceptable within this range.

IMPORTANT :

- When using an oil of different maker or viscosity from the previous one, remove all of the old oil. Never mix two different types of oil.
- If oil level is low, do not run engine.

■ Checking Transmission Fluid Level

1. Park the machine on a flat surface, lower the implement and shut off engine.
2. To check the oil level, draw out the dipstick, wipe it clean, replace it, and draw it out again. Check to see that the oil level lies between the two notches. If the level is too low, add new oil to the prescribed level at the oil inlet.
(See "LUBRICANTS" in "MAINTENANCE" section.)

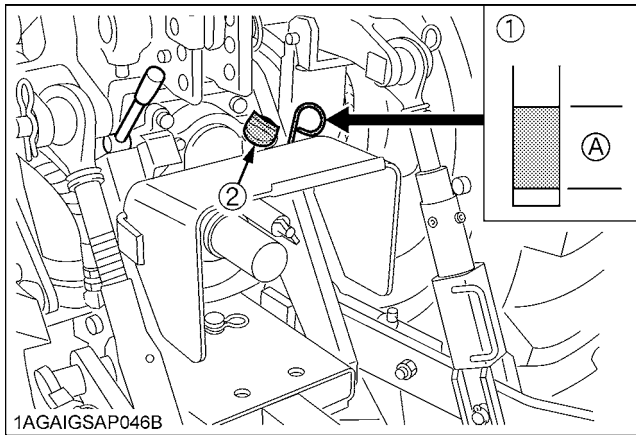

(1) Dipstick (A) Oil level is acceptable within this range.
(2) Oil inlet

IMPORTANT :

- If oil level is low, do not run engine.

■ Checking Coolant Level**CAUTION**

To avoid personal injury:

- Do not remove radiator cap while coolant is hot. When cool, slowly rotate cap to the first stop and allow sufficient time for excess pressure to escape before removing the cap completely.

1. Check to see that the coolant level is between the "FULL" and "LOW" marks of recovery tank.
2. When the coolant level drops due to evaporation, add soft water only up to the full level.
In case of leakage, add anti-freeze and soft water in the specified mixing ratio up to the full level.
(See "Flushing Cooling System and Changing Coolant" in "EVERY 2 YEARS" in "PERIODIC SERVICE" section.)

3. When the coolant level is lower than "LOW" mark of recovery tank, remove the radiator cap and check to see that the coolant level is just below the port. If level is low, add coolant.

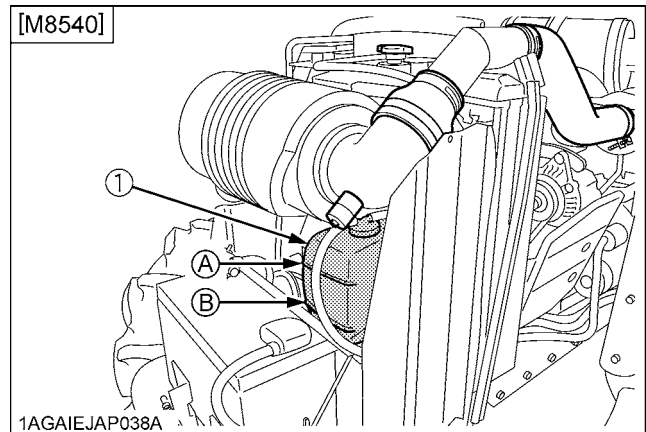

(1) Recovery tank (A) "FULL"
(B) "LOW"

IMPORTANT :

- If the radiator cap has to be removed, follow the caution above and securely retighten the cap.
- Use clean, fresh soft water and anti-freeze to fill the radiator.
- If coolant should leak, consult your local KUBOTA Dealer.

■ Cleaning Evacuator Valve

Open the evacuator valve to get rid of large particles of dust and dirt.

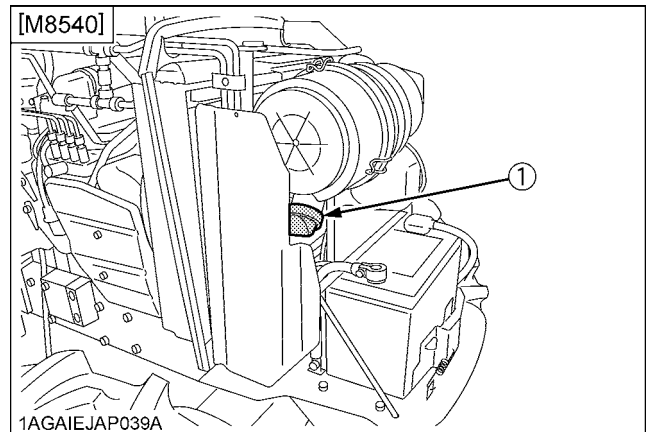

(1) Evacuator valve

■ Cleaning Grill, Radiator Screen, Oil Cooler and Battery Mount



CAUTION

To avoid personal injury:

- Be sure to stop the engine before removing the screen.

◆ Opening the panel

1. To open the panel, pull its front outward.
2. To close the panel, push it inward to get locked.

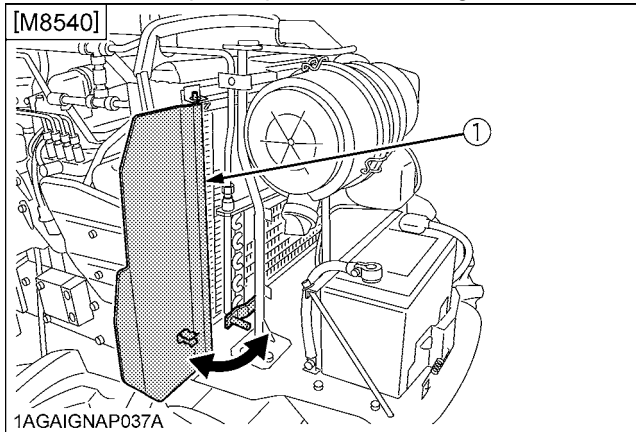

(1) Panel

◆ Cleaning

1. Open the panel.
2. Raise the panel until pin(A) clears the hole, and take out the panel.
3. Check front grill to be sure it is clean from debris.
4. Detach the radiator screen and remove all foreign materials.
5. Check oil cooler and battery mount to be sure they are clean from debris.
6. Attach the panel and close it.

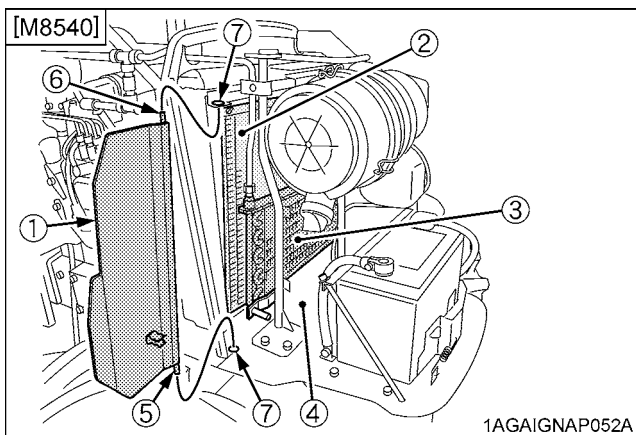

(1) Panel (5) Pin (A)
 (2) Radiator screen (6) Pin (B)
 (3) Oil cooler (7) Hole
 (4) Battery mount

IMPORTANT :

- Grill and screen must be clean from debris to prevent engine from overheating and to allow good air intake for air cleaner.

■ Checking Brake Pedal



WARNING

To avoid personal injury:

- Be sure brake pedals have equal adjustment when using locked together. Incorrect or unequal brake pedal adjustment can cause the tractor to swerve or roll-over.

1. Inspect the brake pedals for free travel, and smooth operation.
2. Adjust if incorrect measurement is found: (See "Adjusting Brake Pedal" in "EVERY 100 HOURS" in "PERIODIC SERVICE" section.)

■ Checking Parking Brake

Pull the parking brake lever to apply the brakes. With the key switch at "ON" position, the parking brake indicator on the instrument panel lights up.

To release the brakes, push in the button at the tip of the parking brake lever and tilt down the lever.

NOTE :

- Make sure the (P) lamp on the instrument panel goes off when parking brake lever is down.

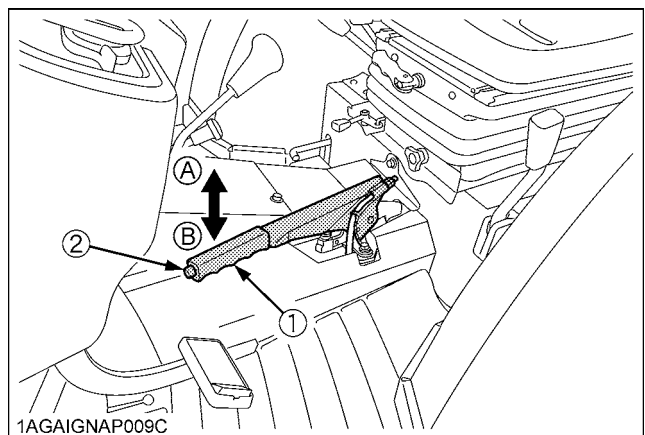

(1) Parking brake lever (A) "PULL"
 (2) Release button (B) "RELEASE"

■ Checking Gauges, Meter and Easy Checker(TM)

1. Inspect the instrument panel for broken gauge(s), meter(s) and Easy Checker(TM) lamps.
2. Replace if broken.

■ Checking Head Light, Turn Signal / Hazard Light etc.

1. Inspect the lights for broken bulbs and lenses.
2. Replace if broken.

■ Checking Seat Belt and ROPS

1. Always check condition of seat belt and ROPS attaching hardware before operating tractor.
2. Replace if damaged.

EVERY 50 HOURS

■ Checking Engine Start System



CAUTION

To avoid personal injury:

- Do not allow anyone near the tractor while testing.
- If the tractor does not pass the test, do not operate the tractor.

◆ Preparation before testing.

1. Place all control levers in the "NEUTRAL" position.
2. Set the parking brake and stop the engine.

◆ Test: Switch for the shuttle shift lever.

1. Follow the instruction of "PARKING THE TRACTOR". (See "PARKING THE TRACTOR" in "SAFE OPERATION" section.)
2. Sit on the operator's seat.
3. Shift the shuttle shift lever to the forward or reverse position.
4. Depress the clutch pedal fully.
5. Disengage the PTO clutch control switch or lever.
6. Turn the key to "START" position.
7. The engine must not crank.
8. If it cranks, consult your local KUBOTA Dealer for this service.

◆ Test: Switch for the PTO clutch control switch or lever.

1. Follow the instruction of "PARKING THE TRACTOR". (See "PARKING THE TRACTOR" in "SAFE OPERATION" section.)
2. Sit on the operator's seat.
3. Engage the PTO clutch control switch or lever.
4. Depress the clutch pedal fully.
5. Shift the shuttle shift lever to the neutral position.
6. Turn the key to "START" position.
7. The engine must not crank.
8. If it cranks, consult your local KUBOTA Dealer for this service.

◆ Test: Checking Operator Presence Control (O.P.C.) System.

1. Follow the instruction of "PARKING THE TRACTOR". (See "PARKING THE TRACTOR" in "SAFE OPERATION" section.)
2. Sit on the operator's seat.
3. Make sure the PTO drive shaft is disconnected from any attached implement.
4. Start the engine.
5. Engage the PTO clutch control switch or lever. The PTO should begin to rotate. Disengage the PTO clutch control switch or lever.
6. While lifting yourself from the seat, engage the PTO clutch control switch or lever.
 - (1) The PTO should begin to rotate and a buzzer should sound.
 - (2) Disengage the PTO clutch control switch or lever.
 - (3) If the buzzer does not sound, shut off the engine and consult your local KUBOTA Dealer for immediate servicing of the PTO OPC.
7. If the PTO OPC is operating properly, shut off the engine, and reconnect the implement drive shaft to the PTO. Restart the engine per the available instructions.



WARNING

To avoid serious injury or death:

- Before checking the PTO OPC, make sure that the PTO drive shaft should be disconnected from the tractor.
- If the buzzer does not sound during the PTO OPC check procedure, shut off engine and consult your local KUBOTA Dealer for immediate servicing of the PTO OPC.
- The unit should not be operated until servicing is completed.

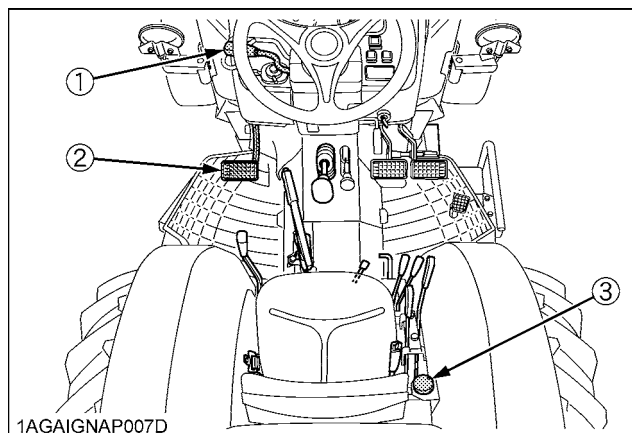

- (1) Shuttle shift lever
- (2) Clutch pedal
- (3) PTO clutch control switch

■Checking Wheel Bolt Torque

CAUTION

To avoid personal injury:

- Never operate tractor with a loose rim, wheel, or axle.
- Any time bolts and nuts are loosened, retighten to specified torque.
- Check all bolts and nuts frequently and keep them tight.

Check wheel bolts and nuts regularly especially when new. If they are loose, tighten them as follows.

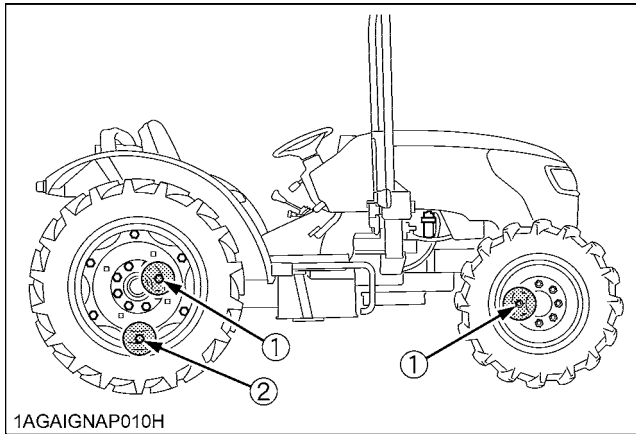

N-m (kgf-m)

(1)	(2)
260 to 304 (26.5 to 31.0)	244 (24.9)

EVERY 100 HOURS

■Lubricating Grease Fittings

Apply a small amount of multipurpose grease to the following points every 100 hours:

If you operated the machine in extremely wet and muddy conditions, lubricate grease fittings more often.

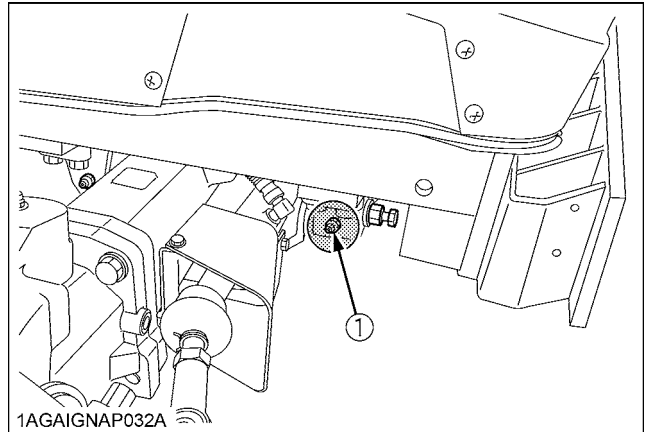

(1) Grease fitting (Front axle support)

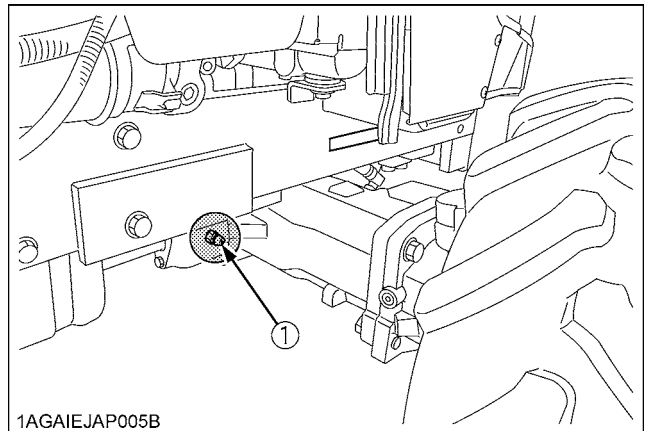

(1) Grease fitting (Front axle support)

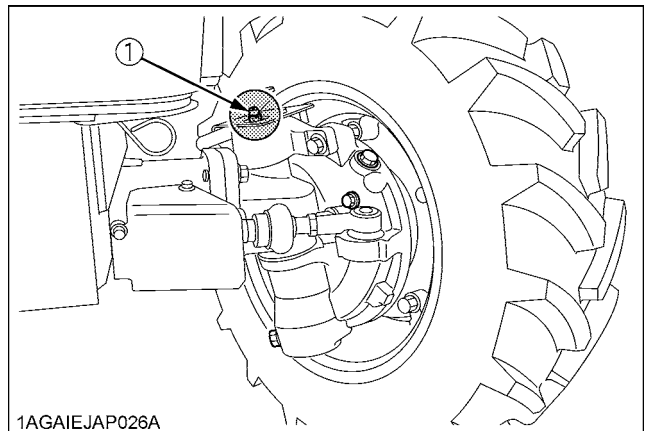

(1) Grease fitting (Front axle gear case support) [RH, LH]

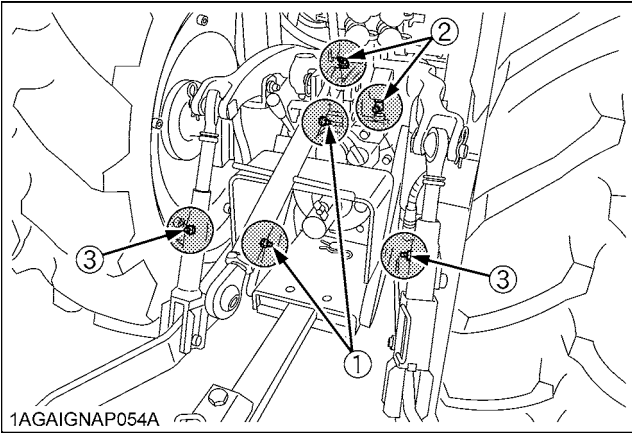

- (1) Grease fitting (Top link)
- (2) Grease fitting (Top link bracket)
- (3) Grease fitting (Lifting rod)

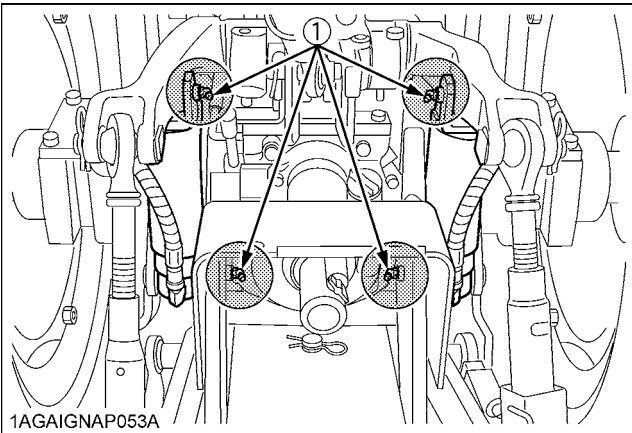

- (1) Grease fitting (Hydraulic lift cylinders pin)

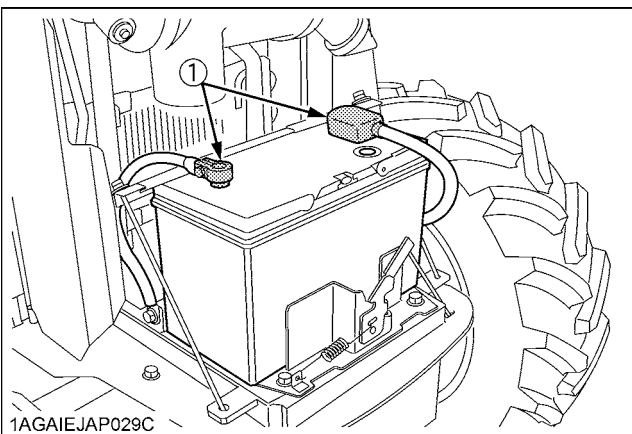

- (1) Battery terminals

■ Cleaning Air Cleaner Primary Element

1. Remove the air cleaner cover and primary element.
2. Clean the primary element:
 - (1) When dry dust adheres to the element, blow compressed air from the inside, turning the element. Pressure of compressed air must be under 205 kPa (2.1 kgf/cm², 30 psi).
 - (2) When carbon or oil adheres to the element, soak the element in detergent for 15 minutes then wash it several times in water, rinse with clean water and dry it naturally. After element is fully dried, inspect inside of the element with a light and check if it is damaged or not.
3. Replace air cleaner primary element:
Once yearly or after every sixth cleaning, whichever comes first.

NOTE :

- Check to see if the evacuator valve is blocked with dust.

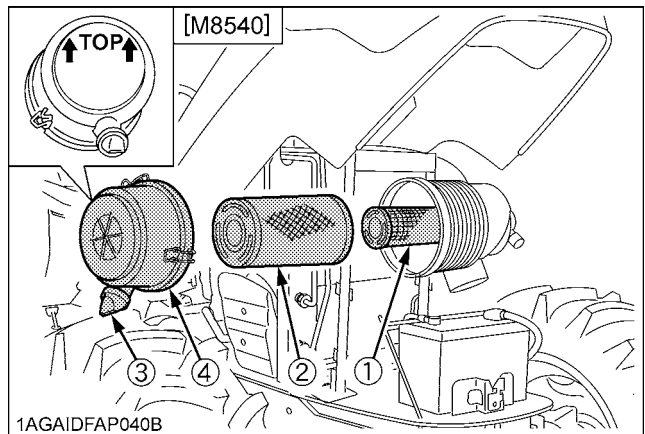

- (1) Secondary (safety) element
- (2) Primary element
- (3) Evacuator valve
- (4) Cover

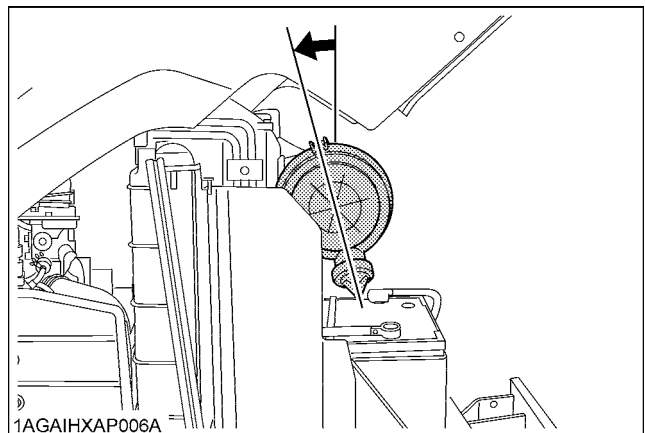

IMPORTANT :

- The air cleaner uses a dry element, never apply oil.
- Do not run the engine with filter element removed.
- Be sure to refit the cover with the arrow ↑ (on the rear of cover) upright. If the cover is improperly fitted, evacuator valve will not function and dust will adhere to the element.
- Do not touch the secondary element except in cases where replacing is required.
(See "Replacing Air Cleaner Secondary Element" in "EVERY 1 YEAR" in "PERIODIC SERVICE" section.)

◆ **Evacuator Valve**

Open the evacuator valve once a week under ordinary conditions - or daily when used in a dusty place - to get rid of large particles of dust and dirt.

■ **Adjusting Alternator Belt Tension**



CAUTION

To avoid personal injury:

- Be sure to stop the engine before checking belt tension.

Proper alternator belt tension	A deflection of between 10 to 12 mm when the belt is pressed in the middle of the span.
--------------------------------	---

1. Stop the engine and remove the key.
2. Apply moderate thumb pressure to belt between pulleys.
3. If tension is incorrect, loosen the alternator mounting bolts and, using a lever placed between the alternator and the engine block, pull the alternator out until the deflection of the belt falls within acceptable limits.
4. Replace alternator belt if it is damaged.

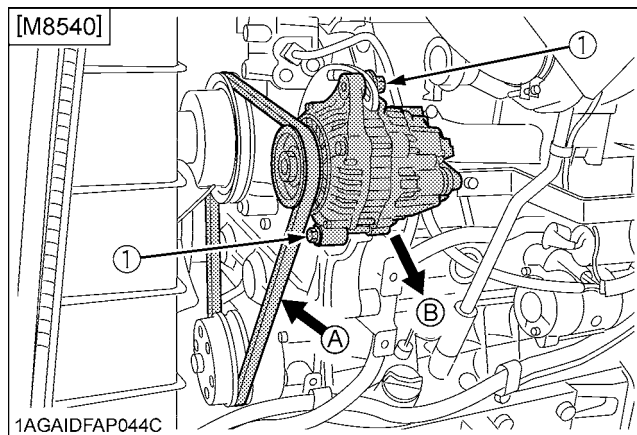

(1) Bolt (A) Check the belt tension (B) To tighten

■ **Checking Fuel Line**

1. Check to see that all lines and hose clamps are tight and not damaged.
2. If hoses and clamps are found worn or damaged, replace or repair them at once.

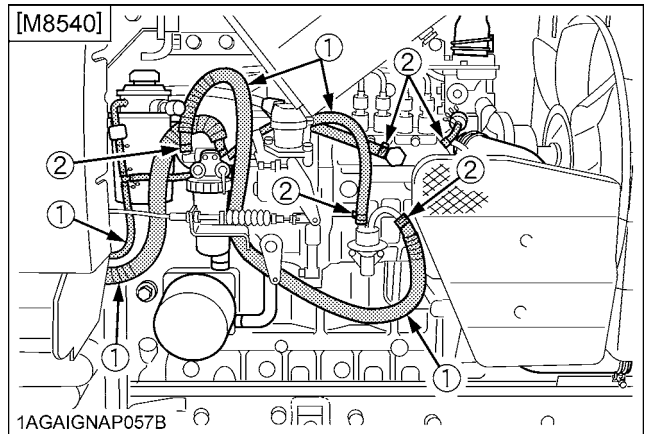

(1) Fuel lines (2) Clamp bands

NOTE :

- If the fuel line is removed, be sure to properly bleed the fuel system.
(See "Bleeding Fuel System" in "SERVICE AS REQUIRED" in "PERIODIC SERVICE" section.)

■ **Adjusting Brake Pedal**



CAUTION

To avoid personal injury:

- Stop the engine and chock the wheels before checking brake pedal.
- To prevent uneven braking, the specification must be within the recommended limit. If found out of the specifications, contact your local KUBOTA Dealer for adjusting the brakes.

◆ **Checking the brake pedal free travel**

Proper brake pedal free travel	7 to 14 mm on the pedal
	Keep the free travel in the right and left brake pedals equal.

1. Set the parking brake.
2. Slightly depress the brake pedals and measure free travel at the top of pedal stroke.

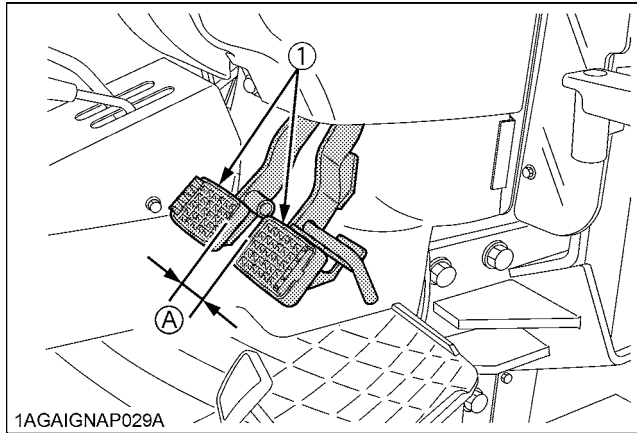

(1) Brake pedals (A) "FREE TRAVEL"

NOTE :

- Brake pedals should be equal when depressed.

◆ **Checking the brake pedal stroke**

Pedal stroke	Less than 100 mm at each pedal
--------------	--------------------------------

1. Disengage the brake pedal lock.
2. Depress the brake pedal several times.
3. Step on the right-hand pedal and measure the level difference (pedal stroke) between this pedal and the left-hand pedal.
4. Do the same for the left-hand pedal.

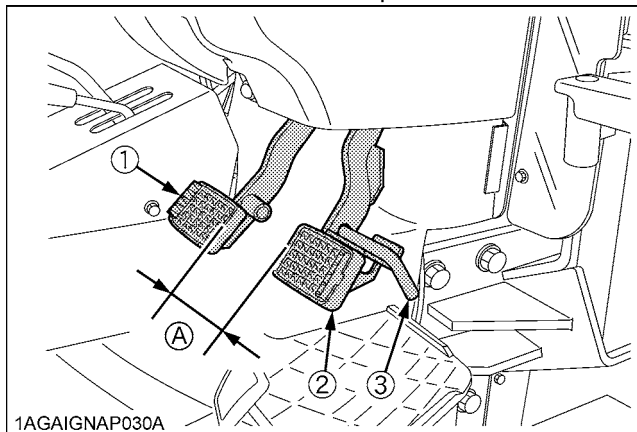

(1) Brake pedal (LH) (2) Brake pedal (RH) (3) Brake pedal lock (A) "PEDAL STROKE"

◆ **Checking the equalizer working level (anti-imbalance device)**

1. Gently step on both brake pedals at once.
2. Further step on the right-hand pedal (the left-hand pedal slightly raises itself) and measure the level difference between the pedals.
3. Do the same for the left-hand pedal.

Equalizer working level	Level difference of over 5 mm between both pedals
-------------------------	---

■ **Adjusting Parking Brake Lever**



CAUTION

To avoid personal injury:

- Stop the engine and chock the wheels before checking parking brake.

Proper parking brake lever free travel	2 notches (Ratchet sound 2)
--	-----------------------------

1. Raise the parking brake lever to the parking position while counting the ratchet sound made by the parking brake lever.
2. If adjustment is needed, loosen the lock nut and adjust the parking brake cable length with in acceptable limit.
3. Retighten the lock nut.

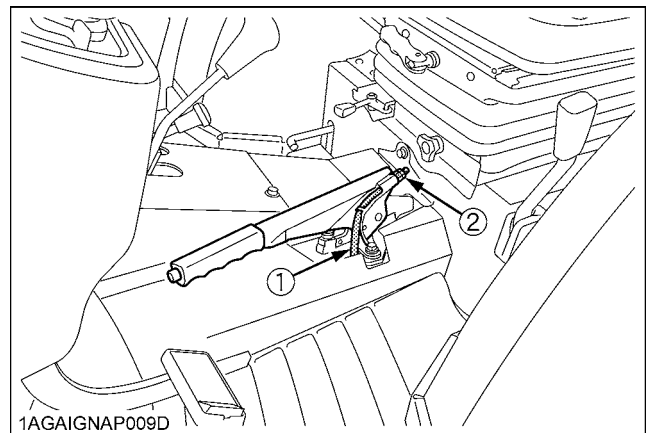

(1) Parking brake cable (2) Lock nut

■ Checking Battery Condition

DANGER

To avoid the possibility of battery explosion:
For the refillable type battery, follow the instructions below.

- Do not use or charge the refillable type battery if the fluid level is below the LOWER (lower limit level) mark. Otherwise, the battery component parts may prematurely deteriorate, which may shorten the battery's service life or cause an explosion. Check the fluid level regularly and add distilled water as required so that the fluid level is between the UPPER and LOWER levels.

CAUTION

To avoid personal injury:

- Never remove the battery cap while the engine is running.
- Keep electrolyte away from eyes, hands and clothes. If you are spattered with it, wash it away completely with water immediately and get medical attention.
- Keep open sparks and flames away from the battery at all times. Hydrogen gas mixed with oxygen becomes very explosive.
- Wear eye protection and rubber gloves when working around battery.

The factory-installed battery is of non-refillable type. If the indicator turns white, do not charge the battery but replace it with new one.

Mishandling the battery shortens the service life and adds to maintenance costs.

The original battery is maintenance free, but needs some servicing.

If the battery is weak, the engine will be difficult to start and the lights will be dim. It is important to check the battery periodically.

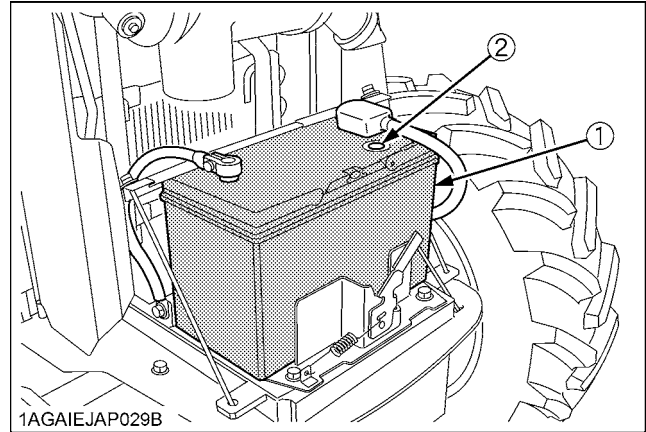

(1) Battery
(2) Indicator

◆ How to read the indicator

Check the battery condition by reading the indicator.

State of indicator display	
Green	Specific gravity of electrolyte and quality of electrolyte are both in good condition.
Black	Needs charging battery.
White	Needs replacing battery.

◆ Battery Charging

CAUTION

To avoid personal injury:

- When the battery is being activated, hydrogen and oxygen gases in the battery are extremely explosive. Keep open sparks and flames away from the battery at all times, especially when charging the battery.
- When charging the battery, ensure the vent caps are securely in place. (if equipped)
- When disconnecting the cable from the battery, start with the negative terminal first. When connecting the cable to the battery, start with the positive terminal first.
- Never check battery charge by placing a metal object across the posts. Use a voltmeter or hydrometer.

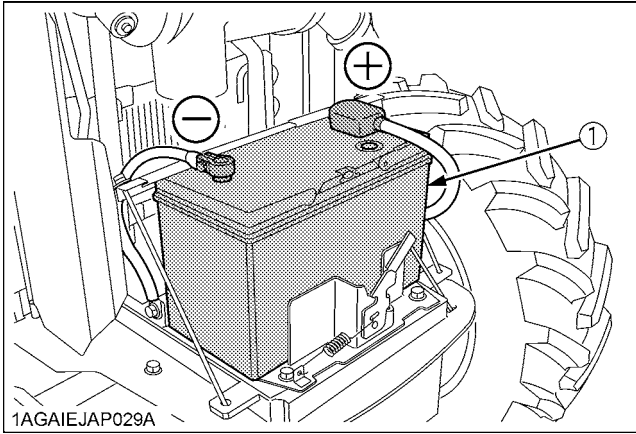

(1) Battery

1. To slow charge the battery, connect the battery positive terminal to the charger positive terminal and the negative to the negative, then recharge in the standard fashion.
2. A boost charge is only for emergencies. It will partially charge the battery at a high rate and in a short time. When using a boost-charged battery, it is necessary to recharge the battery as early as possible. Failure to do this will shorten the battery's service life.
3. The battery is charged if the indicator display turns green from black.
4. When exchanging an old battery for a new one, use battery of equal specification shown in **table 1**.

Table 1

Battery Type	Volts (V)	Capacity at 5H.R(A.H)
GP31(105E41R)	12	85.3

Reserve Capacity (min)	Cold Cranking Amps	Normal Charging Rate (A)
160	900	11

◆ **Direction for Storage**

1. When storing the tractor for long periods of time, remove the battery from tractor, adjust the electrolyte to the proper level and store in a dry place out of direct sunlight.
2. The battery self-discharges while it is stored. Recharge it once every three months in hot seasons and once every six months in cold seasons.

EVERY 200 HOURS

■ **Checking Radiator Hose and Clamp**

Check to see if radiator hoses are properly fixed every 200 hours of operation or six months, whichever comes first.

1. If hose clamps are loose or water leaks, tighten bands securely.
2. Replace hoses and tighten hose clamps securely, if radiator hoses are swollen, hardened or cracked.

Replace hoses and hose clamps every 2 years or earlier if checked and found that hoses are swollen, hardened or cracked.

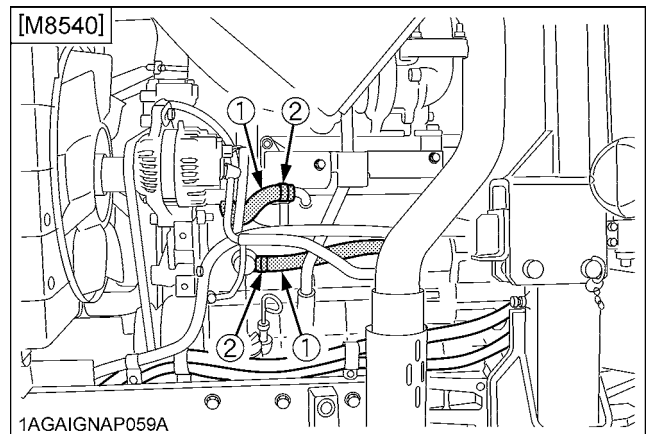
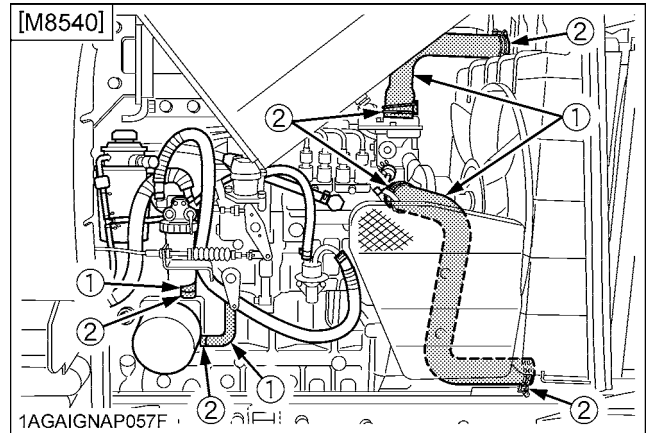

(1) Radiator hoses
(2) Hose clamps

◆ **Precaution at Overheating**

Take the following actions in the event the coolant temperature is nearly or more than the boiling point, what is called "Overheating"

1. Park the tractor in a safe place and keep the engine unloaded idling.
2. Don't stop the engine suddenly, but stop it after about 5 minutes of unloaded idling.
3. Keep yourself well away from the machine for further 10 minutes or while the steam blows out.

4. Check that there are no dangers such as burns. Get rid of the causes of overheating according to the manual, see "TROUBLESHOOTING" section, and then, start again the engine.

■ Checking Intake Air Line

1. Check to see that hoses and hose clamps are tight and not damaged.
2. If hoses and clamps are found worn or damaged, replace or repair them at once.

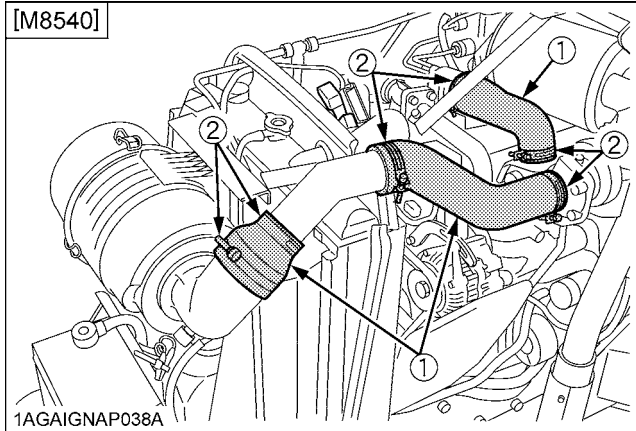

(1) Hose
(2) Hose clamps

■ Checking Power Steering Line

1. Check to see that all lines and hose clamps are tight and not damaged.
2. If hoses and clamps are found worn or damaged, replace or repair them at once.

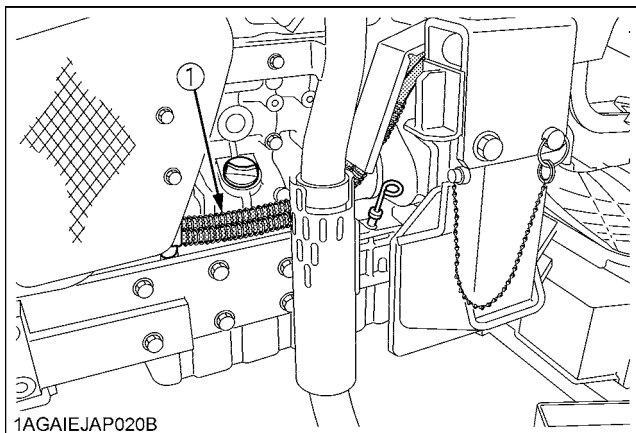

(1) Power steering pressure hoses

■ Adjusting Toe-in

Proper toe-in	2 to 8 mm
---------------	-----------

1. Park tractor on a flat place.
2. Turn steering wheel so front wheels are in the straight ahead position.
3. Lower the implement, lock the park brake and stop the engine.
4. Measure distance between tire beads at front of tire, at hub height.
5. Measure distance between tire beads at rear of tire, at hub height.
6. Front distance should be shorter than rear distance. If not, adjust tie rod length.

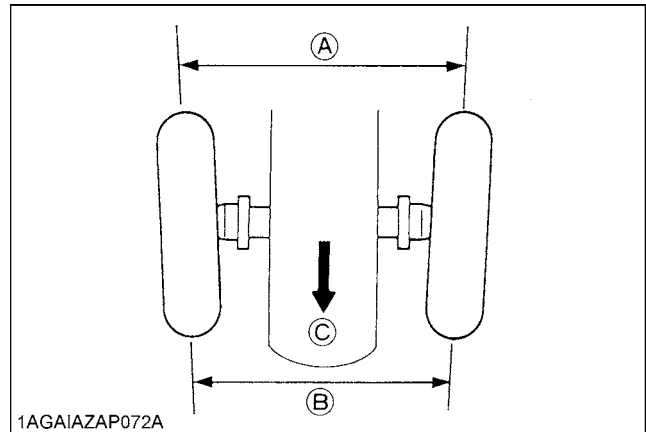

(A) Wheel - to - wheel distance at rear
(B) Wheel - to - wheel distance at front
(C) "FRONT"

◆ Adjusting procedures

1. Detach the snap ring.
2. Loosen the tie-rod nut.
3. Turn the tie-rod joint to adjust the rod length until the proper toe-in measurement is obtained.
4. Retighten the tie-rod nut.
5. Attach the snap ring of the tie-rod joint.

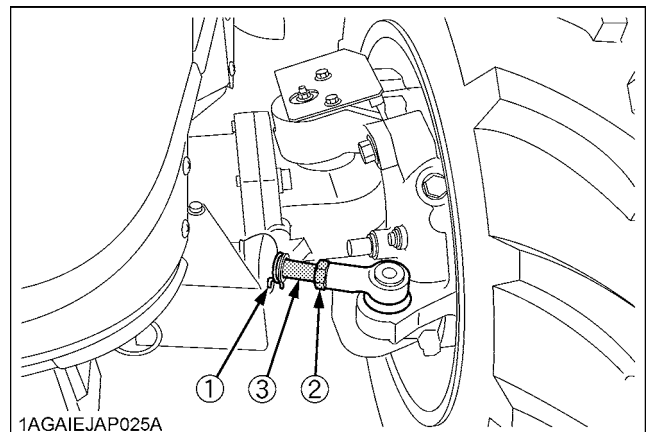

(1) Snap ring
(2) Tie-rod nut
167 to 196 N-m (17 to 20 kgf-m)
(3) Tie-rod joint

■ Draining Fuel Tank Water

Loosen the drain plugs at the bottom of the fuel tanks to let sediments, impurities and water out of the tanks. Finally tighten up the plugs.

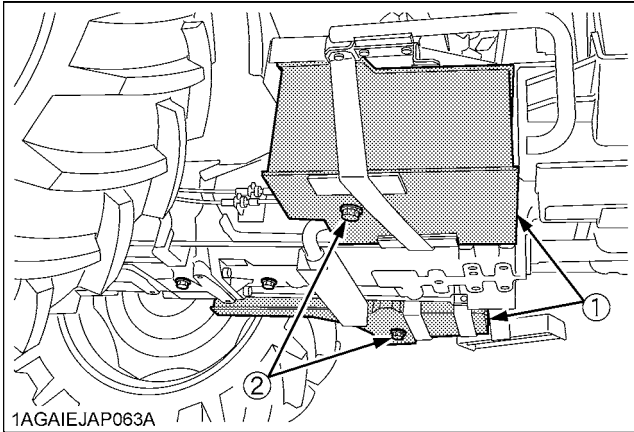

(1) Fuel Tank
(2) Drain plugs

IMPORTANT :

- If the fuel contains poor qualities with much water in it, drain the fuel tank at shorter intervals.
- Drain the fuel tank before operating the tractor after a long period of storage.

EVERY 300 HOURS

■ Changing Engine Oil



CAUTION

To avoid personal injury:

- Be sure to stop the engine before changing the oil.
- Allow engine to cool down sufficiently, oil can be hot and can burn.

1. To drain the used oil, remove the drain plug at the bottom of the engine and drain the oil completely into the oil pan.
All the used oil can be drained out easily when the engine is still warm.
2. After draining reinstall the drain plug.
3. Fill with the new oil up to the upper notch on the dipstick.
(See "LUBRICANTS" in "MAINTENANCE" section.)

Oil capacity with filter	10.7 L
--------------------------	--------

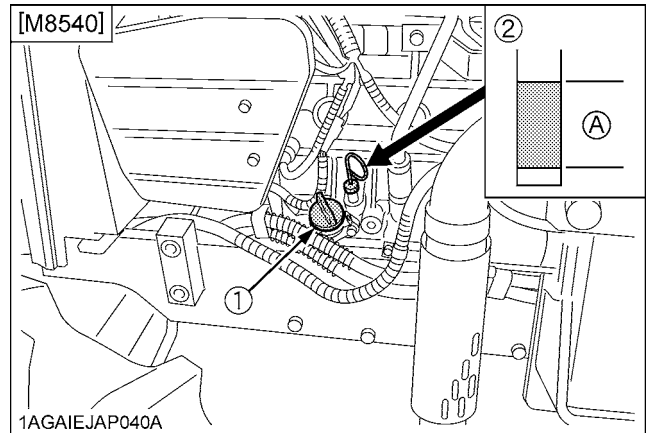

(1) Oil inlet (A) Oil level is acceptable within this range
(2) Dipstick

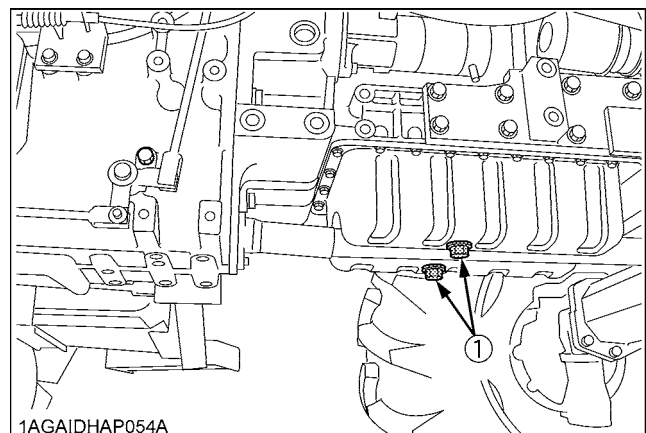

(1) Drain plug

■ Replacing Hydraulic Oil Filter

◆ Cleaning Magnetic Filter



CAUTION

To avoid personal injury:

- Be sure to stop the engine before changing the oil filter cartridge.
- Allow engine to cool down sufficiently, oil can be hot and can burn.

1. Remove the drain plug at the bottom of the transmission case and drain the oil completely into an oil pan.
2. After draining reinstall the drain plug.

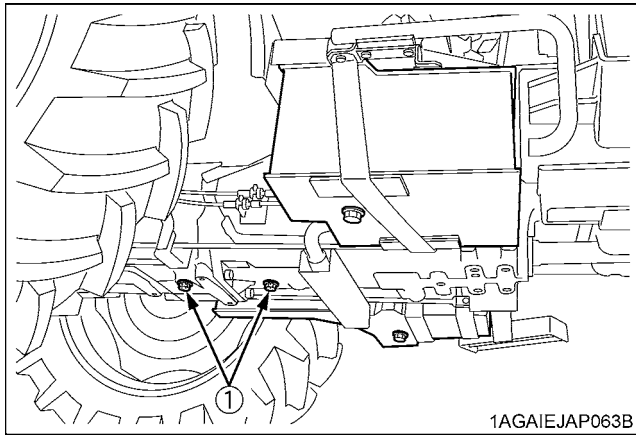

(1) Drain plug

3. Remove the two oil filters.
4. Wipe off metal filings from the magnetic filter with a clean rag.

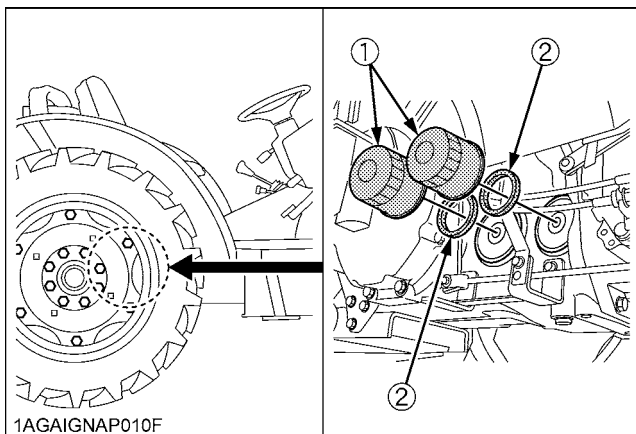

(1) Hydraulic oil filter
(2) Magnetic filter (Wipe off metal filings)

5. Put a film of clean transmission oil on the rubber seal of the new filters.
6. Tighten the filter quickly until it contacts the mounting surface.
Tighten filter by hand an additional 1/2 turn only.

7. After the new filters have been replaced, fill the transmission oil up to the upper notch on the dipstick.

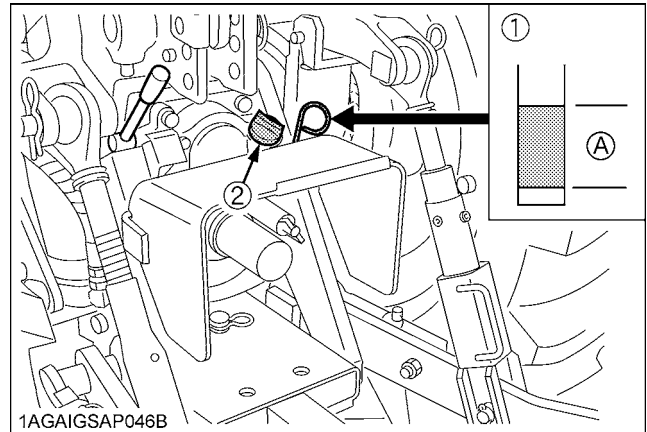

(1) Dipstick (A) Oil level is acceptable within this range
(2) Oil inlet

8. After running the engine for a few minutes, stop the engine and check the oil level again, add oil to the prescribed level.
9. Make sure that the transmission fluid doesn't leak pass the seal on the filters.

IMPORTANT :

- To prevent serious damage to the hydraulic system, use only a KUBOTA genuine filter.
- Do not operate the tractor immediately after changing the transmission fluid.
Run the engine at medium speed for a few minutes to prevent damage to the transmission.

EVERY 400 HOURS

■ Replacing Fuel Filter

1. Remove the fuel filter.
2. Put a film of clean fuel on rubber seal of new filter.
3. Tighten the filter quickly until it contacts the mounting surface.
Tighten filter by hand an additional 1/2 turn only.
4. Bleed the fuel system.
(See "Bleeding Fuel System" in "SERVICE AS REQUIRED" in "PERIODIC SERVICE" section.)

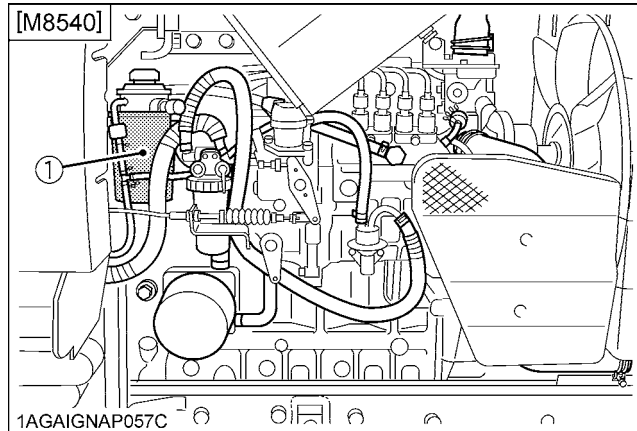

(1) Fuel filter

■ Cleaning Water Separator

This job should not be done in the field, but in a clean place.

1. Close the fuel cock.
2. Unscrew the retainer ring and remove the cup, and rinse the inside with kerosene.
3. Take out the element and dip it in the kerosene to rinse.
4. After cleaning, reassemble the water separator, keeping out dust and dirt.
5. Bleed the fuel system.
(See "Bleeding Fuel System" in "SERVICE AS REQUIRED" in "PERIODIC SERVICE" section.)

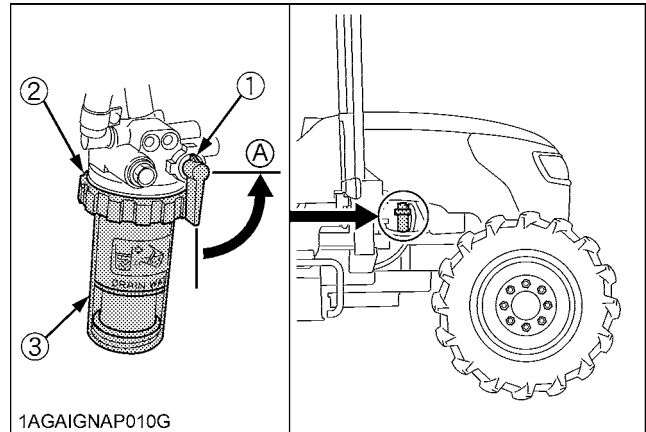

- (1) Fuel cock
(2) Retainer ring
(3) Cup

(A) "CLOSE"

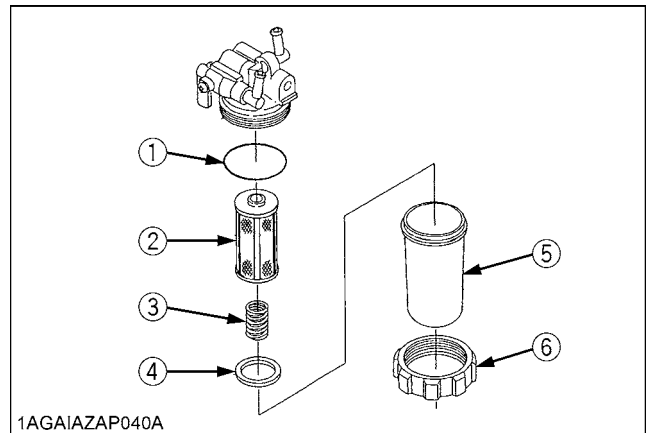

- (1) O ring
(2) Element
(3) Spring
(4) Red float
(5) Cup
(6) Retainer ring

EVERY 600 HOURS

■ Replacing Engine Oil Filter



CAUTION

To avoid personal injury:

- Be sure to stop the engine before changing the oil filter cartridge.
- Allow engine to cool down sufficiently, oil can be hot and can burn.

1. Remove the oil filter.
2. Put a film of clean engine oil on the rubber seal of the new filter.
3. Tighten the filter quickly until it contacts the mounting surface.

Tighten filter by hand an additional 1/2 turn only.

4. After the new filter has been replaced, the engine oil normally decreases a little. Make sure that the engine oil does not leak through the seal and be sure to check the oil level on the dipstick. Then, replenish the engine oil up to the prescribed level.

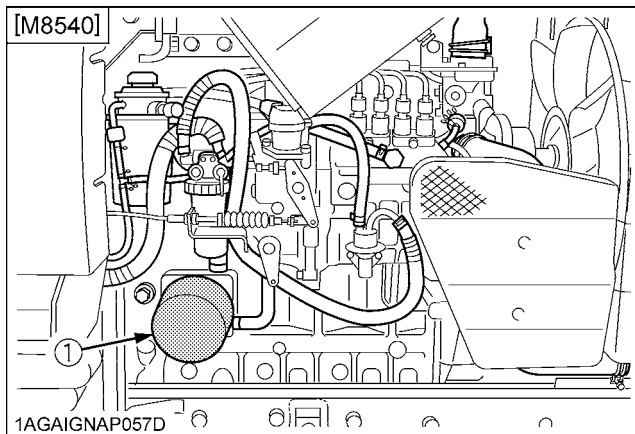

(1) Engine oil filter

IMPORTANT :

- To prevent serious damage to the engine, use only a KUBOTA genuine filter.

■ Changing Transmission Fluid



CAUTION

To avoid personal injury:

- Allow engine to cool down sufficiently, oil can be hot and can burn.

1. To drain the used oil, remove the drain plug at the bottom of the transmission case and drain the oil completely into the oil pan.
2. After draining reinstall the drain plug.
3. Fill with the new KUBOTA SUPER UDT fluid up to the upper notch on the dipstick.
(See "LUBRICANTS" in "MAINTENANCE" section.)

4. After running the engine for a few minutes, stop it and check the oil level again; add oil to prescribed level.

Oil capacity	52 L
--------------	------

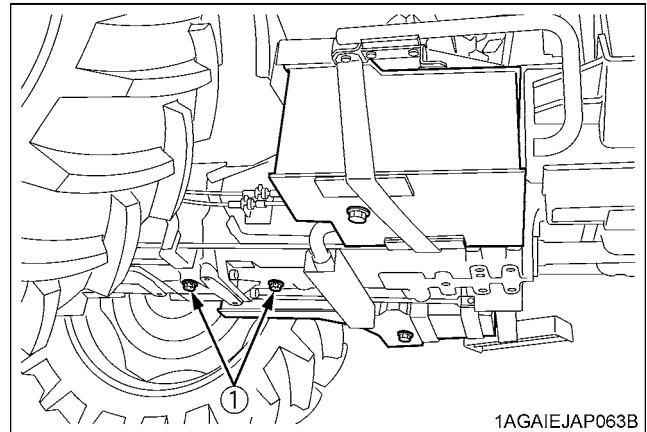

(1) Drain plug

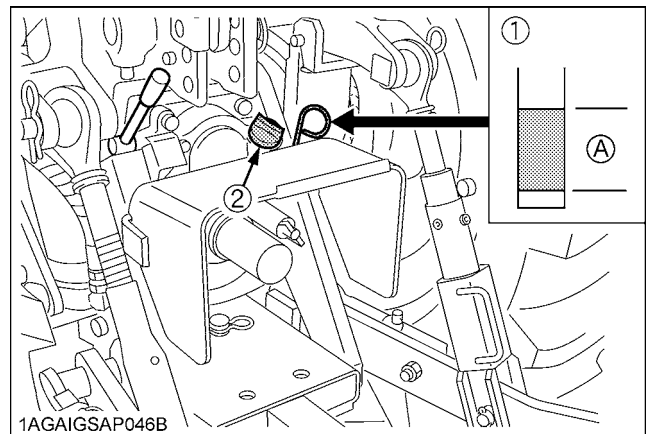

(1) Dipstick
(2) Oil filling plug

(A) Oil level is acceptable within this range

IMPORTANT :

- Do not operate the tractor immediately after changing the transmission fluid.
Run the engine at medium speed for a few minutes to prevent damage to the transmission.

■ Changing Front Axle Gear Case Oil & Front Differential Case Oil

1. To drain the used oil, remove the drain plugs at the both front axle gear cases and filling plugs, and drain the oil completely into the oil pan.
2. After draining reinstall the drain plugs.
3. Fill with the new oil of the specified amount from both filling ports on the front axle gear case, and filling port on the front differential case.
(See "LUBRICANTS" in "MAINTENANCE" section.)
4. After filling reinstall the filling plugs.

	Oil capacity
Front Axle Gear Case	3.0 L for each side
Front Differential Case	5.0 L

NOTE :

- Fill up specified amount certainly although it takes time to pour the oil.

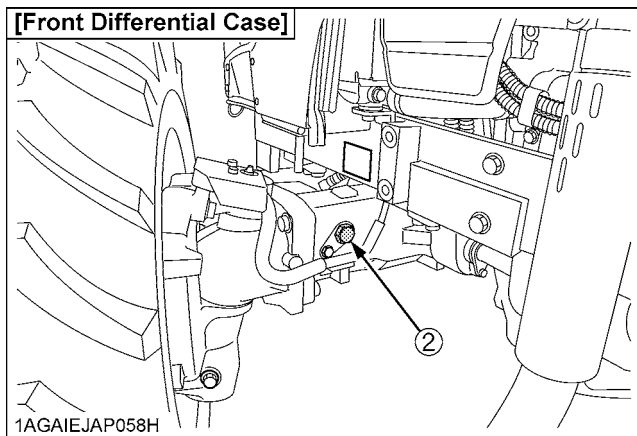
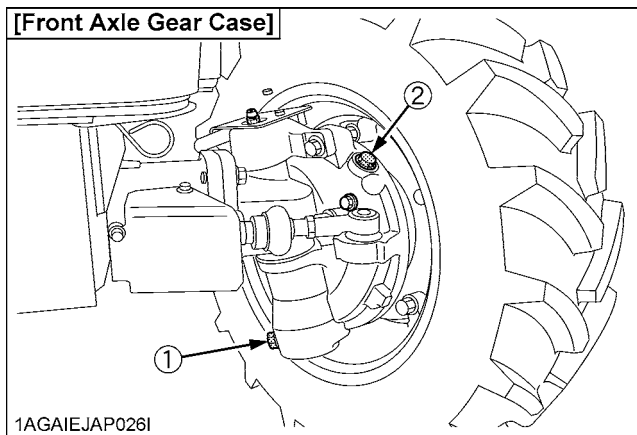

- (1) Drain plug
- (2) Filling plug

IMPORTANT :

- Do not remove the bolt(A).

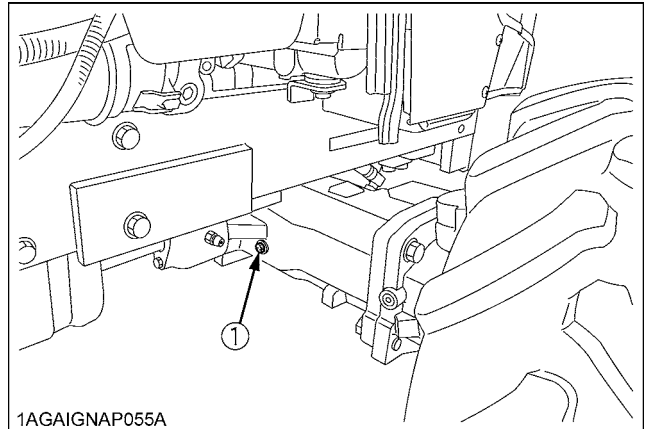

(1) Bolt(A)

■ Adjusting Front Axle Pivot

If the front axle pivot pin adjustment is not correct, front wheel vibration can occur causing vibration in the steering wheel.

◆ **Adjusting procedure**

Loosen the lock nut, screw-in the adjusting screw until seated, then tighten the screw with an additional 1/6 turn. Re-tighten the lock nut.

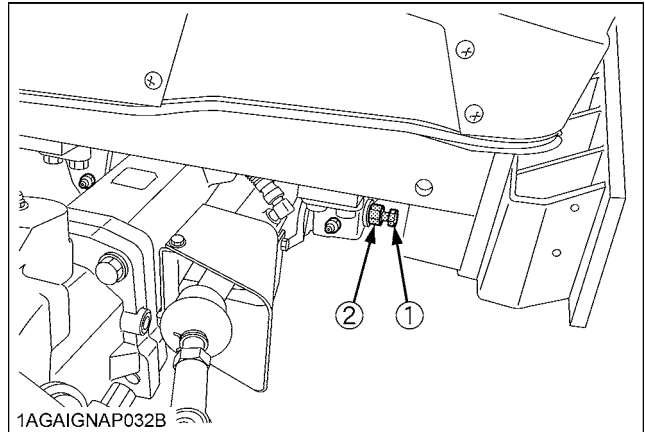

- (1) Adjusting screw
- (2) Lock nut

EVERY 800 HOURS

■ Adjusting Engine Valve Clearance

Consult your local KUBOTA Dealer for this service.

EVERY 1500 HOURS

■ Checking Fuel Injection Nozzle (Injection Pressure)

Consult your local KUBOTA Dealer for this service.

EVERY 3000 HOURS

■ Checking Turbocharger

Consult your local KUBOTA Dealer for this service.

■ Checking Injection Pump

Consult your local KUBOTA Dealer for this service.

■ Checking Intake Air Heater

Consult your local KUBOTA Dealer for this service.

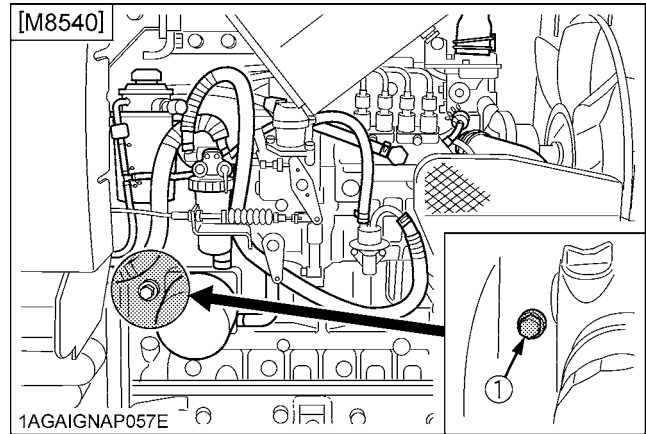

(1) Drain plug

EVERY 1 YEAR

■ Replacing Air Cleaner Primary Element and Secondary Element

(See "Cleaning Air Cleaner Primary Element" in "EVERY 100 HOURS" in "PERIODIC SERVICE" section.)

EVERY 2 YEARS

■ Flushing Cooling System and Changing Coolant



CAUTION

To avoid personal injury:

- Do not remove radiator cap while coolant is hot. When cool, slowly rotate cap to the first stop and allow sufficient time for excess pressure to escape before removing the cap completely.

1. Stop the engine, remove the key and let it cool down.
2. To drain the coolant, open the radiator drain plug, remove the drain plug and remove radiator cap. The radiator cap must be removed to completely drain the coolant.
3. After all coolant is drained, reinstall the drain plug.
4. Fill with clean soft water and cooling system cleaner.
5. Follow directions of the cleaner instruction.
6. After flushing, fill with clean soft water and anti-freeze until the coolant level is just below the radiator cap. Install the radiator cap securely.
7. Fill with coolant up to the "FULL" mark of recovery tank.
8. Start and operate the engine for few minutes.
9. Stop the engine, remove the key and let cool.
10. Check coolant level of recovery tank and add coolant if necessary.
11. Properly dispose of used coolant.

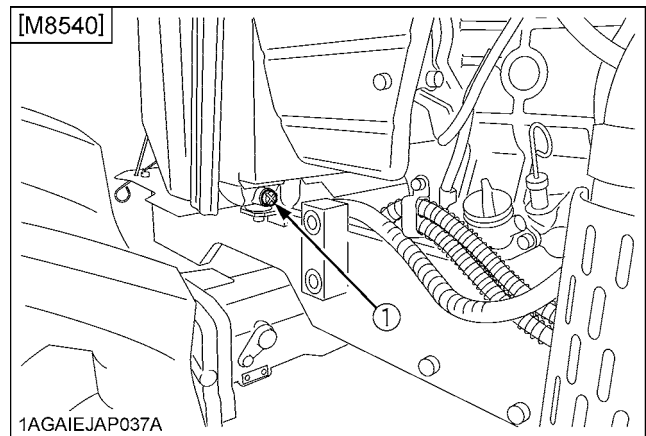

(1) Drain plug ((+) Plus screwdriver)

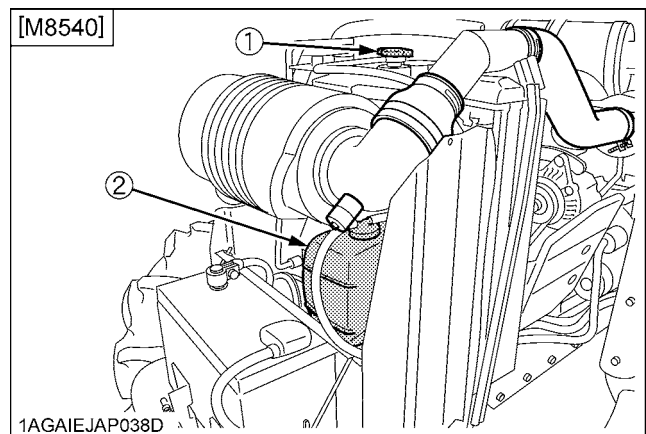

(1) Radiator cap
(2) Recovery tank

IMPORTANT :

- Do not start engine without coolant.
- Use clean, fresh soft water and anti-freeze to fill the radiator and recovery tank.
- When mixing the anti-freeze with water, the anti-freeze mixing ratio is 50 %.

Coolant capacity	9 L
------------------	-----

- Securely tighten radiator cap. If the cap is loose or improperly fitted, water may leak out and the engine could overheat.

■ Anti-Freeze



CAUTION

To avoid personal injury:

- When using antifreeze, put on some protection such as rubber gloves (Antifreeze contains poison.).
- If should drink antifreeze, throw up at once and take medical attention.
- When antifreeze comes in contact with the skin or clothing, wash it off immediately.
- Do not mix different types of Antifreeze. The mixture can produce chemical reaction causing harmful substances.
- Antifreeze is extremely flammable and explosive under certain conditions. Keep fire and children away from antifreeze.
- When draining fluids from the engine, place some container underneath the engine body.
- Do not pour waste onto the grounds, down a drain, or into any water source.
- Also, observe the relevant environmental protection regulations when disposing of antifreeze.

If it freezes, coolant can damage the cylinders and radiator. If the ambient temperature falls below 0 °C or before a long-term storage, let out cooling water completely, or mix fresh water with long-life coolant and fill the radiator and recovery tank with the mixture.

1. Long-life coolant (hereafter LLC) comes in several types. Use ethylene glycol (EG) type for this engine.
2. Before employing LLC-mixed cooling water, fill the radiator with fresh water and empty it again. Repeat this procedure 2 or 3 times to clean up the inside.
3. Mixing the LLC
Put the LLC in cooling water in the percentage (%) for a target temperature. When mixing, stir it up well, and then fill into the radiator.
4. The procedure for the mixing of water and antifreeze differs according to the make of the antifreeze and the ambient temperature. Refer to SAE J1034 standard, more specifically also to SAE J814c.

IMPORTANT :

- When the antifreeze is mixed with water, the antifreeze mixing ratio must be less than 50%.

Vol % Anti-freeze	Freezing Point	Boiling Point*
	°C	°C
40	-24	106
50	-37	108

- * At 1.013 x 10⁵Pa (760mmHg) pressure (atmospheric). A higher boiling point is obtained by using a radiator pressure cap which permits the development of pressure within the cooling system.

5. Adding the LLC
 - (1) Add only water if the mixture reduces in amount by evaporation.
 - (2) If there is a mixture leak, add the LLC of the same manufacturer and type in the same mixture percentage.
 - * Never add any long-life coolant of different manufacturer. (Different brands may have different additive components, and the engine may fail to perform as specified.)
6. When the LLC is mixed, do not employ any radiator cleaning agent. The LLC contains anticorrosive agent. If mixed with the cleaning agent, sludge may build up, adversely affecting the engine parts.
7. Kubota's genuine long-life coolant has a service life of 2 years. Be sure to change the coolant every 2 years.

NOTE :

- The above data represent industry standards that necessitate a minimum glycol content in the concentrated antifreeze.
- When the coolant level drops due to evaporation, add water only to keep the antifreeze mixing ratio less than 50%. In case of leakage, add antifreeze and water in the specified mixing ratio before filling in to the radiator.

■ Replacing Radiator Hose (Water pipes)

Replace the hoses and clamps.

(See "Checking Radiator Hose and Clamp" in "EVERY 200 HOURS" in "PERIODIC SERVICE" section.)

■ Cleaning Master Cylinder Filter

Consult your local KUBOTA Dealer for this service.

■ Replacing Power Steering Hose

Consult your local KUBOTA Dealer for this service.

■ Replacing Fuel Hose

Consult your local KUBOTA Dealer for this service.

■ Replacing Intake Air Line

Consult your local KUBOTA Dealer for this service.

■ Replacing Parking Brake Cable

Consult your local KUBOTA Dealer for this service.

■ Replacing Master Cylinder Kit

Consult your local KUBOTA Dealer for this service.

■ Replacing Equalizer Kit

Consult your local KUBOTA Dealer for this service.

■ Replacing Brake Seal 1 and 2

Consult your local KUBOTA Dealer for this service.

■ Replacing Lift Cylinder Hose

Consult your local KUBOTA Dealer for this service.

SERVICE AS REQUIRED

■ Bleeding Fuel System

Air must be removed:

1. When the fuel filter or lines are removed.
2. When water is drained from water separator.
3. When tank is completely empty.
4. After the tractor has not been used for a long period of time.

◆ Bleeding procedure is as follows:

1. Fill the fuel tank with fuel, and open the fuel cock.

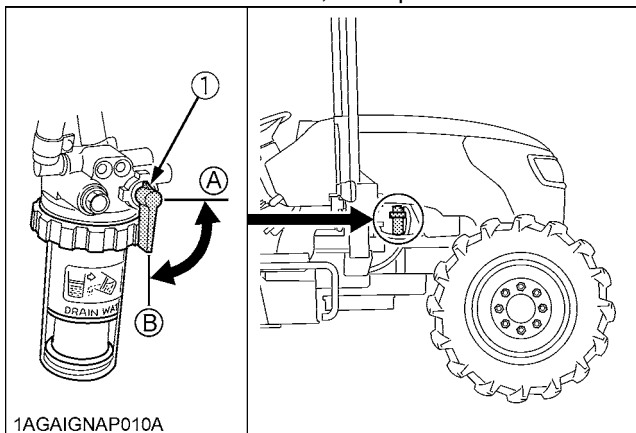

(1) Fuel cock

(A) "CLOSE"

(B) "OPEN"

2. Pump the fuel pump knob(1) located on the top of the fuel filter. The fuel pump knob will pump easily at first and with added resistance as air is purged from the system. To make sure air is completely purged, pinch the fuel overflow hose with fingers, if a pulsation is felt when the knob is pumped, then, no air remains.

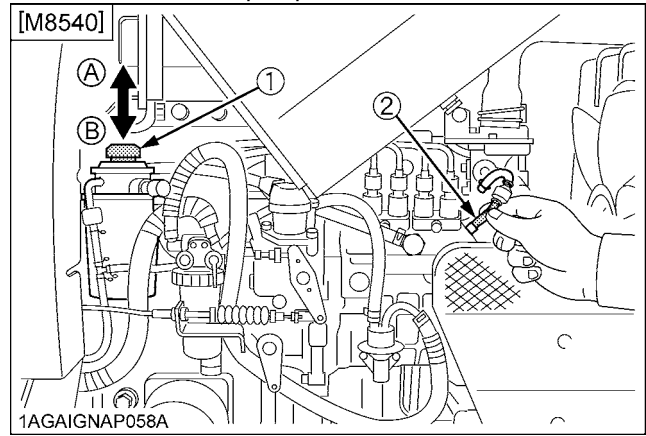

(1) Fuel pump knob

(A) "UP"

(2) Fuel overflow hose

(B) "DOWN"

3. Set the hand throttle lever at the maximum speed position, turn the key switch to start the engine and then reset the throttle lever at the mid speed (around 1500 rpm) position. If engine doesn't start, try it several times at 30 second intervals.

IMPORTANT :

- Do not hold key switch at engine start position for more than 10 seconds continuously. If more engine cranking is needed, try again after 30 seconds.

4. Accelerate the engine to remove the small portion of air left in the fuel system.
5. If air still remains and the engine stops, repeat the above steps.

■ Bleeding Brake System

Consult your local KUBOTA Dealer for this service.

■ Draining Clutch Housing Water

The tractor is equipped with a drain plug under the clutch housing.

After operating in rain, snow or if the tractor has been washed, water may get into the clutch housing.

Remove the drain plug and drain the water, then install the plug again.

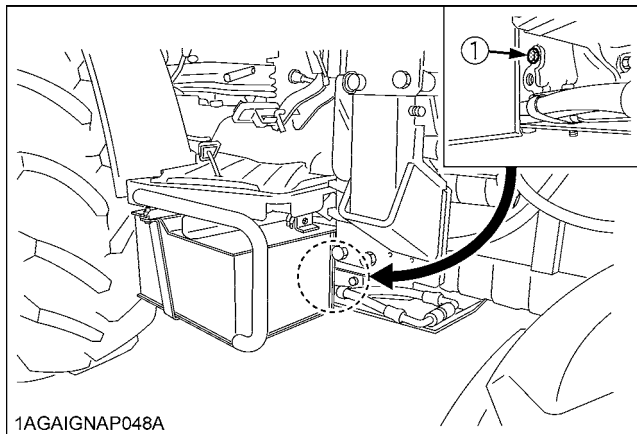

1AGAIGNAP048A

(1) Water drain plug

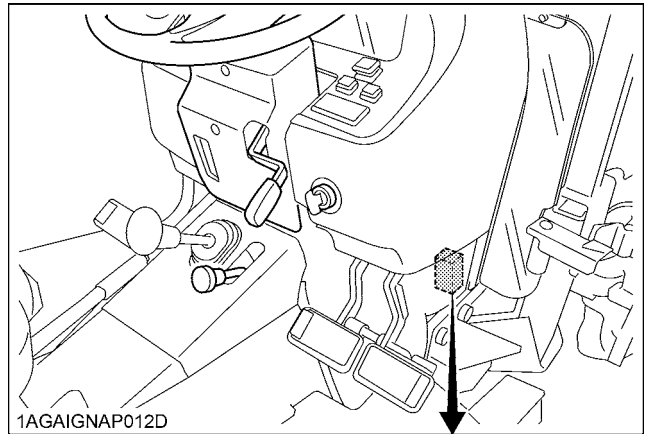

1AGAIGNAP012D

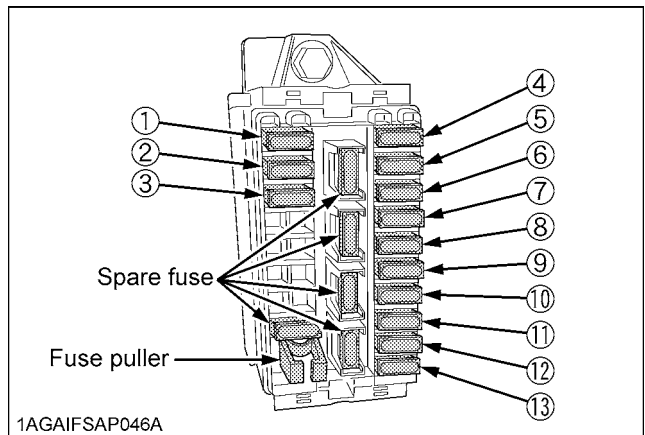

1AGAIFSAP046A

■ Replacing Fuse

The tractor electrical system is protected from potential damage by fuses.

A blown fuse indicates that there is an overload or short somewhere in the electrical system.

If any of the fuses should blow, replace with a new one of the same capacity.

IMPORTANT :

- Before replacing a blown fuse, determine why the fuse blew and make any necessary repairs. Failure to follow this procedure may result in serious damage to the tractor electrical system. Refer to the "TROUBLESHOOTING" section of this manual or your local KUBOTA Dealer for specific information dealing with electrical problems.

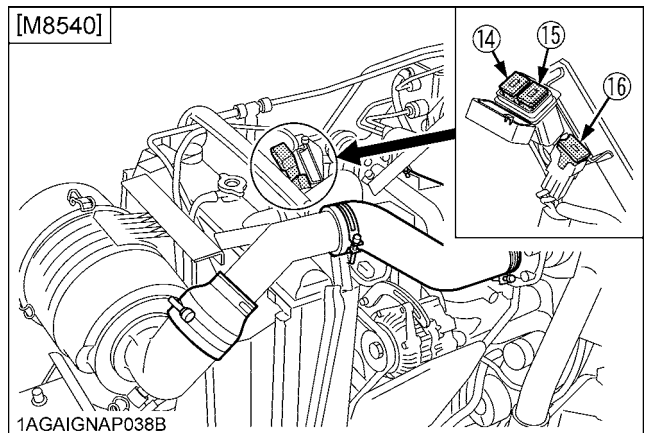

1AGAIGNAP038B

Fuse No.	Capacity (A)	Protected circuit
(1)	10	Horn
(2)	10	Transmission Control
(3)	25	Auxiliary Socket
(4)	15	Work Light (Right)
(5)	15	Work Light (Left)
(6)	5	Alternator, Engine, PTO, Heater
(7)	5	Meter Panel, OPC
(8)	10	Turn Signal
(9)	15	Auxiliary Power
(10)	5	Meter (Back Up)
(11)	20	Head light, Tail Lamp
(12)	15	Flasher (Hazard)
(13)	5	Starter Relay
(14)	40	Key switch, Head light, Hazard
(15)	30	Fuel cut solenoid
(16)	50	Charge, Heater

■ Replacing Light Bulb

Light	Capacity
Head light	12V, 55 / 60 W (H4)
Hazard and Turn signal light (rear)	12V, 21 W
Hazard and Turn signal light (front)	12V, 21 W
Front position light	12V, 10 W
Front work light	12V, 21 W
Brake stop light	12V, 21 W
Tail light	12V, 10 W
Number plate light	12V, 10 W

■ Replacing Head Lamp



CAUTION

To avoid personal injury:

- Be careful not to drop the bulb, hit anything against the lamp, apply excess force, and get the lamp scratched. If broken, glass may cause injury. Pay more attention to halogen lamps in particular, which have high pressure inside.
- Before replacing the lamp, be sure to turn off the light and wait until the bulb cools down, otherwise, you may get burned.

1. While pushing the right and left lock buttons, pull and remove the electrical connector.
2. Remove the rubber boot.
3. Remove the clamping fixture and take out the bulb.

4. Replace with a new bulb and reinstall the head lamp assembly in the reverse order.

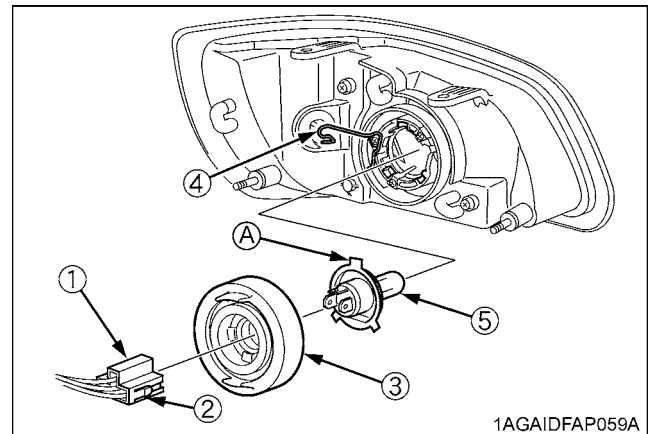

- (1) Electrical connector (A) "Base's wider projection to face upward"
- (2) Lock buttons
- (3) Rubber boot
- (4) Clamping fixture
- (5) Bulb

IMPORTANT :

- Be sure to use a new bulb of the specified wattage.
- Never touch the bulb surface (glass) with bare hands. Fingerprints, for example, may break the bulb.

STORAGE



CAUTION

To avoid personal injury:

- Do not clean the machine while the engine is running.
- To avoid the danger of exhaust fume poisoning, do not operate the engine in a closed building without proper ventilation.
- When storing, remove the key from the key switch to avoid unauthorized persons from operating the tractor and getting injured.

TRACTOR STORAGE

If you intend to store your tractor for an extended period of time, follow the procedures outlined below.

These procedures will insure that the tractor is ready to operate with minimum preparation when it is removed from storage.

1. Check the bolts and nuts for looseness, and tighten if necessary.
2. Apply grease to tractor areas where bare metal will rust also to pivot areas.
3. Detach the weights from the tractor body.
4. Inflate the tires to a pressure a little higher than usual.
5. Change the engine oil and run the engine to circulate oil throughout the engine block and internal moving parts for about five minutes.
6. Keep the PTO clutch control switch or lever at "DISENGAGE" position while tractor is stored for a long period of time.
7. With all implements lowered to the ground, coat any exposed hydraulic cylinder piston rods with grease.
8. Remove the battery from the tractor. Store the battery following the battery storage procedures.
(See "Checking Battery Condition" in "EVERY 100 HOURS" in "PERIODIC SERVICE" section.)
9. Keep the tractor in a dry place where the tractor is sheltered from the elements. Cover the tractor.
10. Store the tractor indoors in a dry area that is protected from sunlight and excessive heat. If the tractor must be stored outdoors, cover it with a waterproof tarpaulin. Jack the tractor up and place blocks under the front and rear axles so that all four tires are off the ground. Keep the tires out of direct sunlight and extreme heat.

IMPORTANT :

- When washing the tractor, be sure to stop the engine. Allow sufficient time for the engine to cool before washing.
- Cover the tractor after the muffler and the engine have cooled down.

REMOVING THE TRACTOR FROM STORAGE

1. Check the tire air pressure and inflate the tires if they are low.
2. Jack the tractor up and remove the support blocks from under the front and rear axles.
3. Install the battery. Before installing the battery, be sure it is fully charged.
4. Check the fan belt tension.
5. Check all fluid levels (engine oil, transmission/hydraulic oil, engine coolant and any attached implements).
6. Start the engine. Observe all gauges. If all gauges are functioning properly and reading normal, move the tractor outside. Once outside, park the tractor and let the engine idle for at least five minutes. Shut the engine off and walk around tractor and make a visual inspection looking for evidence of oil or water leaks.
7. With the engine fully warmed up, release the parking brake and test the brakes for proper adjustment as you move forward. Adjust the brakes as necessary.

TROUBLESHOOTING

ENGINE TROUBLESHOOTING

If something is wrong with the engine, refer to the table below for the cause and its corrective measure.

Trouble		Cause	Countermeasure
Engine is difficult to start or won't start.		<ul style="list-style-type: none"> No fuel flow. 	<ul style="list-style-type: none"> Check the fuel tank and the fuel filter. Replace filter if necessary.
		<ul style="list-style-type: none"> Air or water is in the fuel system. 	<ul style="list-style-type: none"> Check to see if the fuel line coupler bolt and nut are tight. Bleed the fuel system (See "Bleeding Fuel System" in "SERVICE AS REQUIRED" in "PERIODIC SERVICE" section.)
		<ul style="list-style-type: none"> In winter, oil viscosity increases, and engine revolution is slow. 	<ul style="list-style-type: none"> Use oils of different viscosities, depending on ambient temperatures. Use engine block heater (Optional)
		<ul style="list-style-type: none"> Battery becomes weak and the engine does not turn over quick enough. 	<ul style="list-style-type: none"> Clean battery cables & terminals. Charge the battery. In cold weather, always remove the battery from the engine, charge and store it indoors. Install it on the tractor only when the tractor is going to be used.
		<ul style="list-style-type: none"> Intake air heater system trouble. 	<ul style="list-style-type: none"> Check to see if the slow blow fuse of the intake air heater blows. Check to see if the intake air heater functions in cold weather.
Insufficient engine power.		<ul style="list-style-type: none"> Insufficient or dirty fuel. The air cleaner is clogged. 	<ul style="list-style-type: none"> Check the fuel system. Clean or replace the element.
Engine stops suddenly.		<ul style="list-style-type: none"> Insufficient fuel. 	<ul style="list-style-type: none"> Refuel. Bleed the fuel system if necessary.
Exhaust fumes are colored.	Black	<ul style="list-style-type: none"> Fuel quality is poor. Too much oil. The air cleaner is clogged. 	<ul style="list-style-type: none"> Change the fuel and fuel filter. Check the proper amount of oil. Clean or replace the element.
	Blue white	<ul style="list-style-type: none"> The inside of exhaust muffler is dumped with fuel. Injection nozzle trouble. Fuel quality is poor. 	<ul style="list-style-type: none"> Check to see if the intake air heater functions in cold weather. Heat the muffler by applying load to the engine. Check the injection nozzle. Change the fuel and fuel filter.
Engine overheats		<ul style="list-style-type: none"> Engine overloaded 	<ul style="list-style-type: none"> Shift to lower gear or reduce load.
		<ul style="list-style-type: none"> Low coolant level 	<ul style="list-style-type: none"> Fill cooling system to the correct level; check radiator and hoses for loose connections or leaks.
		<ul style="list-style-type: none"> Loose or defective fan belt 	<ul style="list-style-type: none"> Adjust or replace fan belt.
		<ul style="list-style-type: none"> Dirty radiator core or grille screens 	<ul style="list-style-type: none"> Remove all trash.
		<ul style="list-style-type: none"> Coolant flow route corroded 	<ul style="list-style-type: none"> Flush cooling system.

If you have any questions, contact your local KUBOTA Dealer.

OPTIONS

Consult your local KUBOTA Dealer for further details.

- Front end weights
For front ballast
- Rear Wheel Weights
For rear ballast
- Double Acting Remote Hydraulic Control Valve with
Detents and Self-Cancelling
- Double Acting Remote Hydraulic Control Valve with
Float Position
- Rear Work Light.
High visibility for night work.